



# Antenna Datasheet

## Active ceramic antenna

Model:

BWGNSCNX18-18B1Y4L120

Description:

BeiDou/GPS active ceramic antenna

Characteristics:

Frequency range:  $1575 \pm 5$  MHz

Frequency range:  $1561 \pm 5$  MHz

IPEX-1 inner hole connector

Structure: right-hand circularly polarized antenna

Cable type: RG1.13

Cable length: 120 mm.

Dimensions: 18 mm × 18 mm × 6.5 mm

Complies with RoHS and REACH regulations



# Contents

1. Product description	3
2. Product specifications	4
3. Physical diagram	5
4. Dimensional drawing	6
5. Test equipment	7-8
6. Performance data	9-10
6.1 Voltage standing wave ratio	9
6.2 Return loss	9
6.3 Gain	10
6.4 Efficiency	10
6.5 Antenna gain and efficiency	10
7. Radiation pattern diagram	11-12
7.1 2D radiation pattern diagram	11
7.2 3D radiation pattern diagram	12

## Legal statement:

In order to provide better service to users, Shenzhen Bat Wireless Technology Co., Ltd. (hereinafter referred to as "Bat Wireless") has endeavored to present detailed and accurate product information in this manual. However, since the contents of this manual are subject to time sensitivity, Bat Wireless cannot fully guarantee the timeliness and applicability of this document at all times. Bat Wireless reserves the right to update the contents of this manual without prior notice. To obtain the latest version of the information, esteemed users are advised to visit the official Bat Wireless website regularly or contact Bat Wireless staff. Thank you for your understanding and support!

**Copyright Statement:** All contents of this product manual (including text, charts, logos, and designs) are protected by copyright law and international copyright treaties. No organization or individual may reproduce, modify, distribute, transmit, or use any part or all of this manual in any form (including electronic, mechanical, or photocopying methods) without prior written authorization from our company. Infringers will bear corresponding legal liabilities. All rights reserved.

**Trademark statement:** The product names and corporate logos of Bat Wireless appearing in this manual are the lawful property of our company (including its affiliated entities). Any unauthorized use, reproduction, or imitation is strictly prohibited. Third-party trademarks cited in this manual belong to their respective owners. Their use herein is for descriptive purposes only and does not imply any commercial association or authorization. Our company reserves all rights to pursue legal action against infringement.

**Disclaimer:** The product information contained in this manual is provided for reference only. Actual product performance may vary depending on environmental conditions and configuration differences. Our company makes no express or implied warranties regarding the accuracy, completeness, or applicability of the contents of this manual, and assumes no liability for any direct or indirect losses arising from the use of or inability to use its contents. Users should independently evaluate the applicability of the product and comply with proper operational standards. The final right of interpretation rests with our company.



## BWGNSCNX18-18B1Y4L120

### Part number description

BW	Company	Bat Wireless
GNS	Frequency	GNSS
C	Name	Ceramic antenna
N	Type	Internal
X	Constant	X
18-18	Dimensions	18-18mm
B1	Connector	IPEX1
Y	Type	Active antenna
4	Ceramic thickness	4mm
L	Wire length	Wire length
120	Length	120mm

### Model selection table

Connector	IPEX-1	IPEX-2	IPEX-3	IPEX-4	IPEX-5	SMA	Customizable options available
Cable length	25	50	120	200	250	300	Customizable options available
Cable type	RG0.81	RG1.13	RG1.37	RG174	RG178	RG316	Customizable options available

## 1. Product description

The Bat Wireless BWGNSCNX18-18B1Y4L120 is a ceramic antenna operating at frequency bands of 1575 MHz and 1561 MHz. Utilizing a specialized ceramic dielectric material, the antenna achieves compact size while maintaining excellent radiation efficiency and low dielectric loss. Featuring low loss and high stability, the ceramic dielectric exhibits minimal signal attenuation and outstanding temperature stability, making it suitable for automotive, outdoor, and other demanding environments, as well as for low-power applications. Designed with right-hand circular polarization to match the polarization mode of BeiDou satellite signals, it provides strong resistance to multipath interference and improves positioning accuracy. Easy to integrate, typically equipped with ANT connection pins and ground pins for convenient soldering or modular design.

#### Typical Application Scenarios:

Automotive and Transportation Sector: in-vehicle navigation systems, commercial fleet management, and intelligent transportation infrastructure.

Consumer Electronics and Portable Devices: smartphones/tablets, outdoor sports equipment, and shared economy devices

Internet of Things (IoT) and Asset Tracking: logistics tracking and agricultural IoT

Aerospace and Defense: unmanned aerial vehicles (UAVs), satellite communication terminals, and military equipment.

Bat Wireless provides customized services to optimize your devices. With a well-established R&D team, we can respond quickly to meet your specific requirements. If you have any requests, please contact our sales representatives or FAE.



## 2. Product specification

Parameters	Typical value	Units	Notes
<b>Electrical characteristics</b>			
Antenna type	Ceramic antenna		
Frequency range	1575±5, 1561±5	MHz	
Input impedance	50	Ω	
V.S.W.R (voltage standing wave ratio)	<3		
Passive antenna gain	1561: -0.6, 1575: 0.6	dBi	
LNA gain	21.5	dBi	
Polarization type	Right-hand circular polarization (RHCP)		
Power capacity	50	W	
Current consumption	4.3	mA	
DC voltage	1.8-3.6	V	
<b>Mechanical characteristics</b>			
Dimensions	18 x 18 x 6.5	mm	
Connector type	IPEX-1 (customizable)		
Cable type	RG1.13 (customizable)		
Cable length	120 (customizable)	mm	
Mounting method	Press-fit		
Color	Silver white		
Material	Ceramic		
Weight	8.56	g	
<b>Environmental characteristics</b>			
Waterproof rating	-		
RoHS compliant	Complies		
Operating temperature	-45~ +85	°C	
Storage temperature	-45~ +85	°C	



### 3. Physical diagram / dimensions

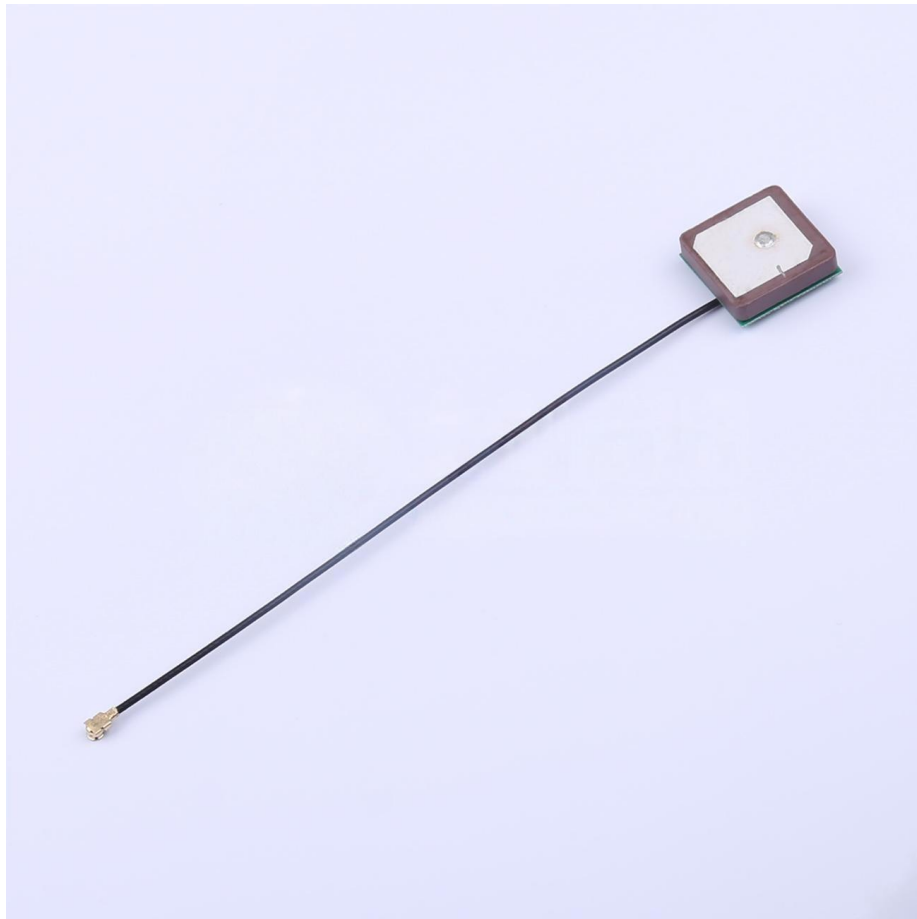

Images are for reference only; the actual product shall prevail.



**4. Dimensional drawing / mechanical drawing**

**PARTS DRAWING**

**ROHS Compliant**

REV	PRODUCT NO.	DATE	NAME	DESCRIPTION

- Antenna Assembly Precautions:
1. Assembly Orientation Refer to the prototype or specification document diagram
  2. Coaxial Cables must have a large bend radius when routing.
  3. Secure terminals and ceramic components with adhesive
  4. ESD (Electrostatic Discharge) protection protocols must be followed throughout the entire assembly process.

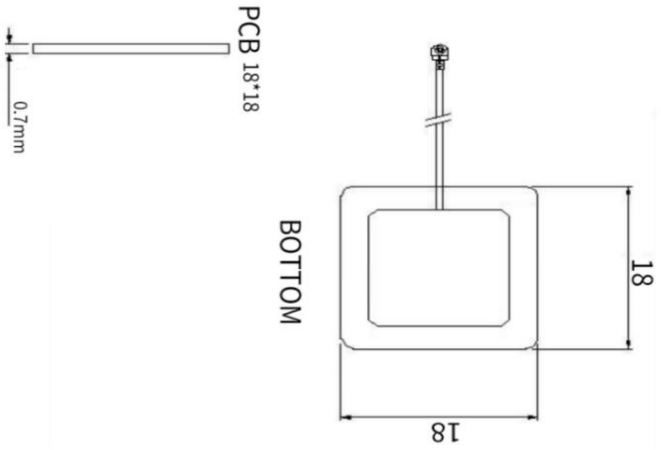
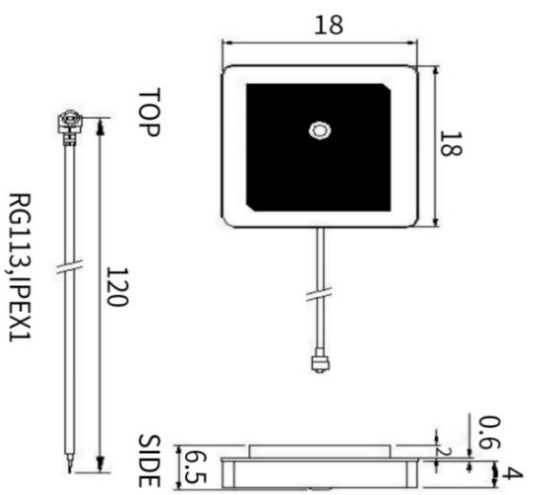

ANGLE PROJECTION 		GENERAL TOLERANCES 100-200 : ± 3.00 50-100 : ± 2.00 25-50 : ± 0.20 10-25 : ± 0.15 1-10 : ± 0.10	
<b>PRODUCT NAME</b>			
GNSS Ceramic Antenna-18*18*4			
UNIT	MM	SIZE	1:3
PAGE	1 OF 1	FORNMT	A4
Operating Temperature : -45°C~85°C Storage Temperature : -45°C~85°C			



## 5. Test equipment



Keysight / E5071C network analyzer



R&amp;S / CMW500 communication tester



R&amp;S / SMBV100B signal generator

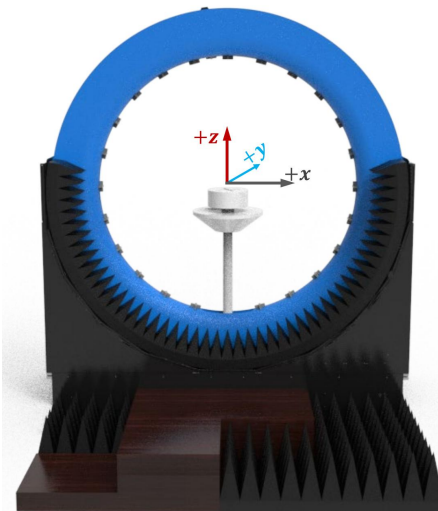

### DT-3500 Datasheet / System Specifications

Specification:	Description
Test frequency range	400MHz-8.5GHz
System size	L*W*H=4*3.5*3.5m
Number of probes	23 (Probe) + 1 (link)
Interval angle	15°
Sampling diameter	2200mm
Carrying capacity	≤40kg

### Testing capability

### Description / capability description

#### Active measurement Active testing

**Capability / Test metrics:** TRP, TIS, EIRP, EIS, etc.  
**Mode / Test standards:** 2G / 3G / 4G / 5G, Wi-Fi b/g/n/a/ac/ax, BT, NB-IoT, Cat-M (eMTC), GPS / BEIDOU / GLONASS, ZigBee, LoRa (Non-Signaling), etc

#### Passive measurement Passive testing

**Test types:** Gain, efficiency, 2D pattern, 3D pattern, pattern roundness, axial ratio, ECC, phase center, etc  
**Polarization type:** Circular polarization, linear polarization, elliptical polarization



## RF link diagram of multi-probe spherical near-field testing system

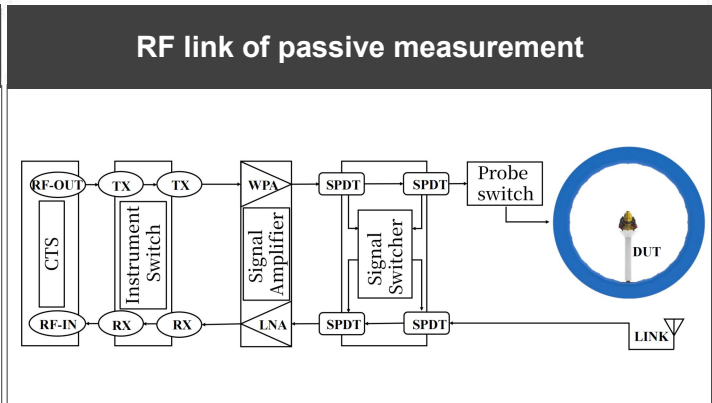
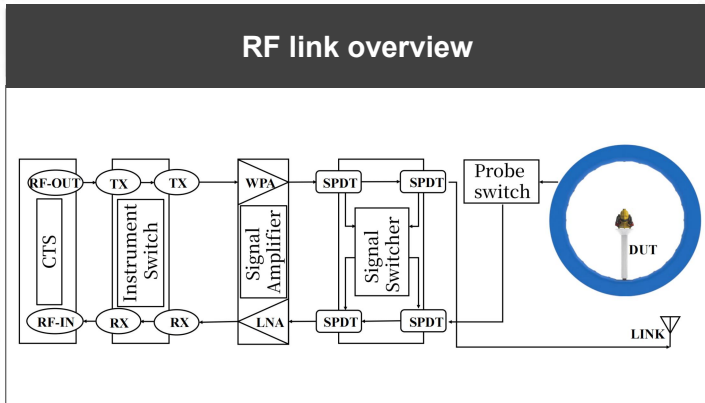
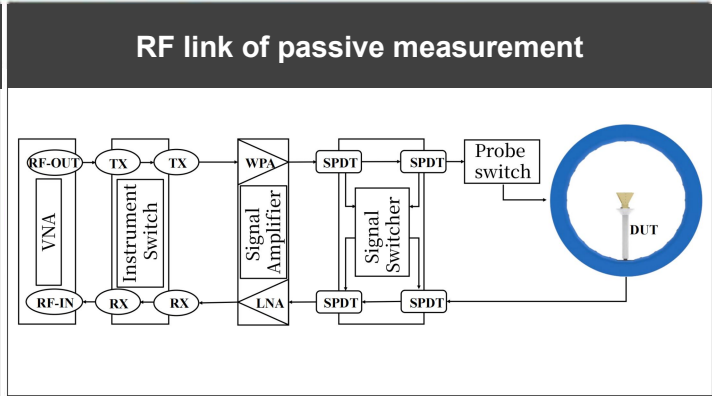
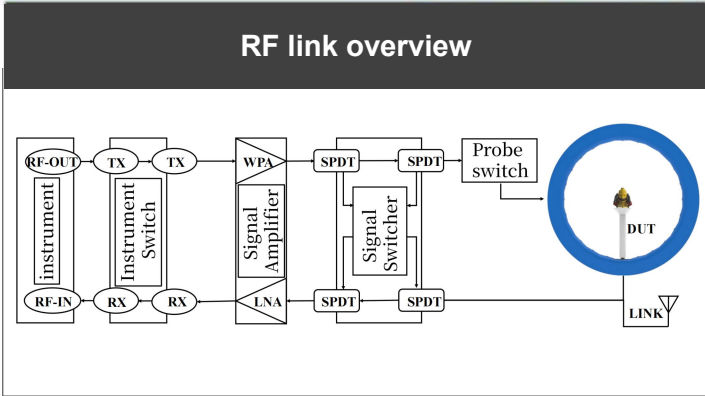



## 6. Performance data

### 6.1 Voltage standing wave ratio (VSWR)

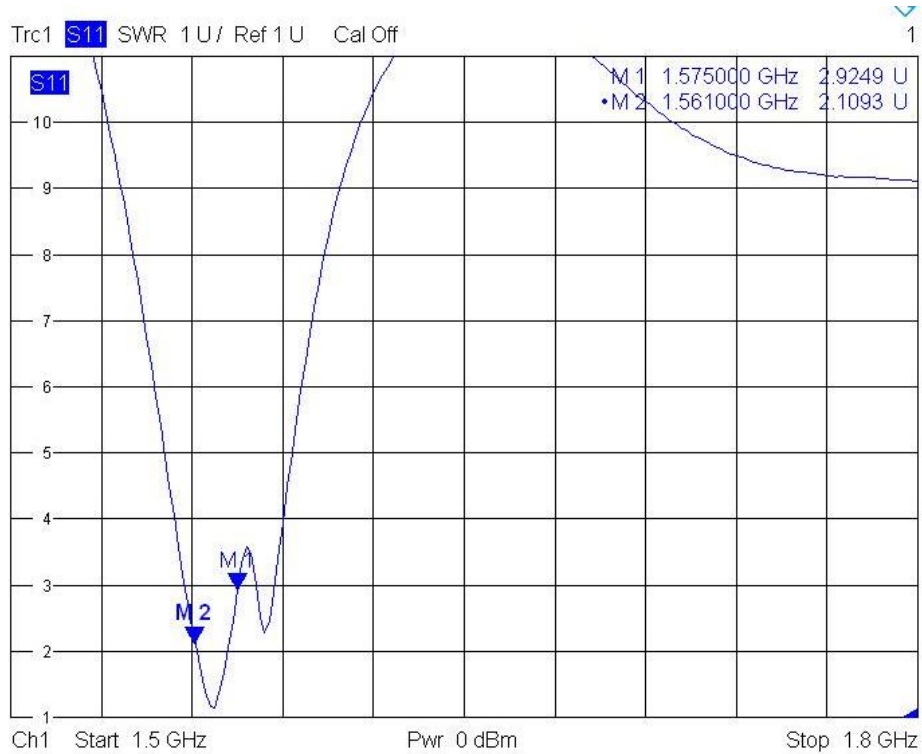

### 6.2 Return loss

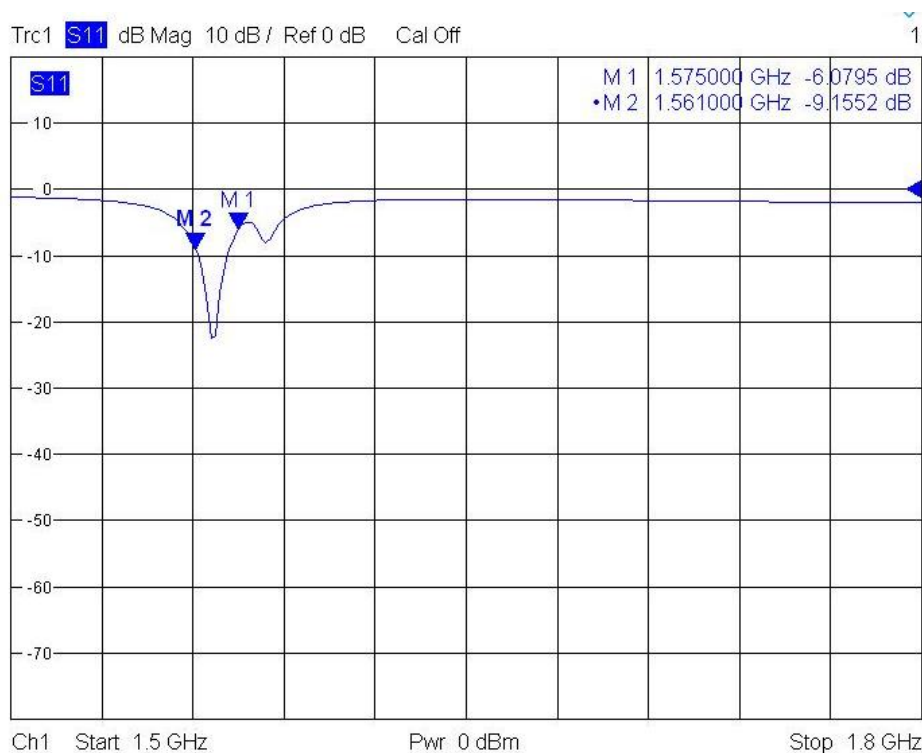



## 6. Performance data

### 6.3 Gain

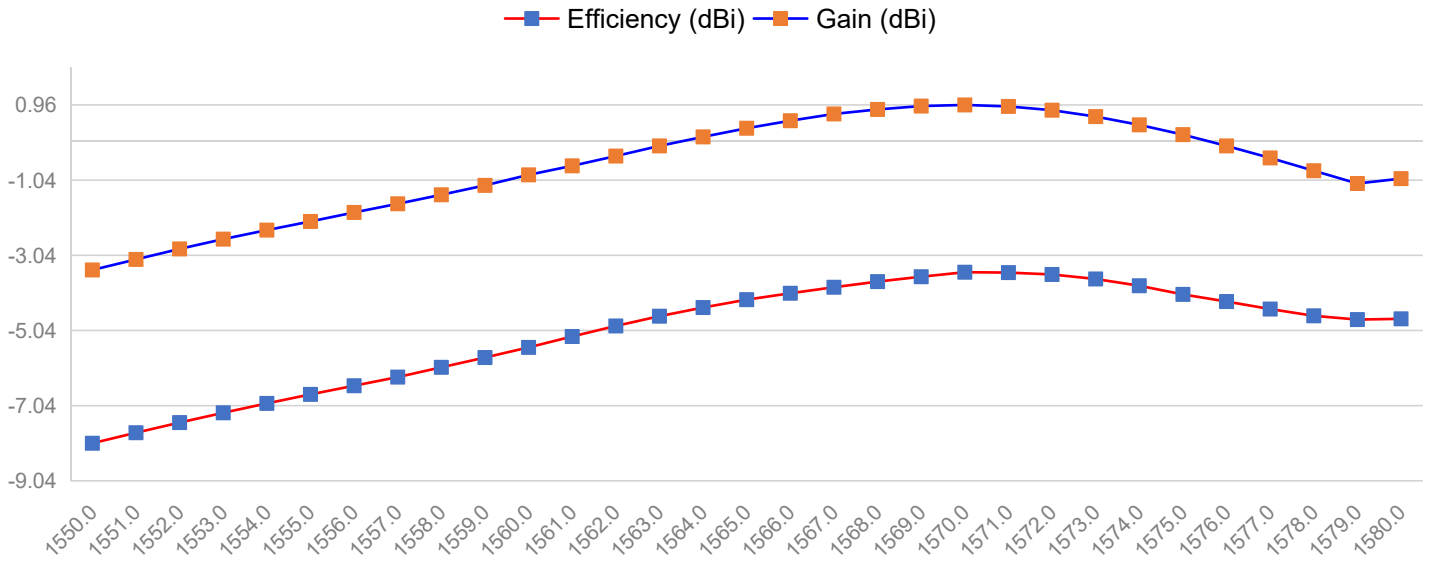

### 6.4 Efficiency

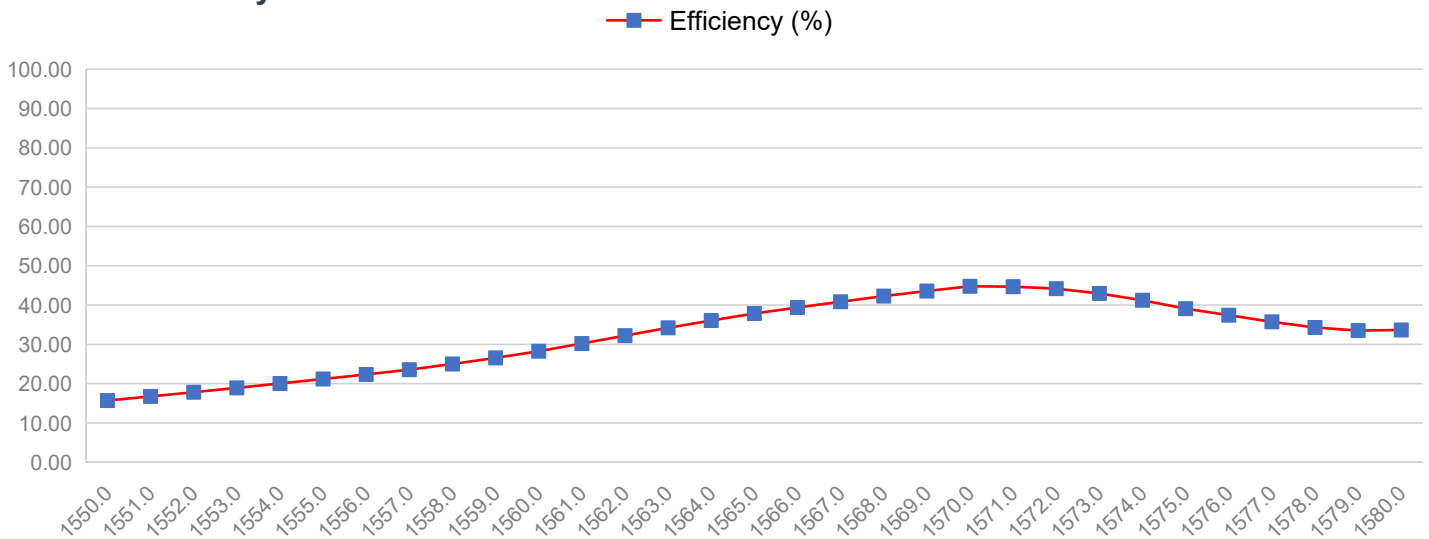

### 6.5 Antenna gain and efficiency

Frequency (MHz)	1561	1570	1575	1580
Maximum gain (dBi)	-0.60	0.97	0.64	-1
Efficiency (%)	30.4	44.70	41.20	33.65

# 7. Radiation patterns

## 7.1 2D Radiation pattern diagram

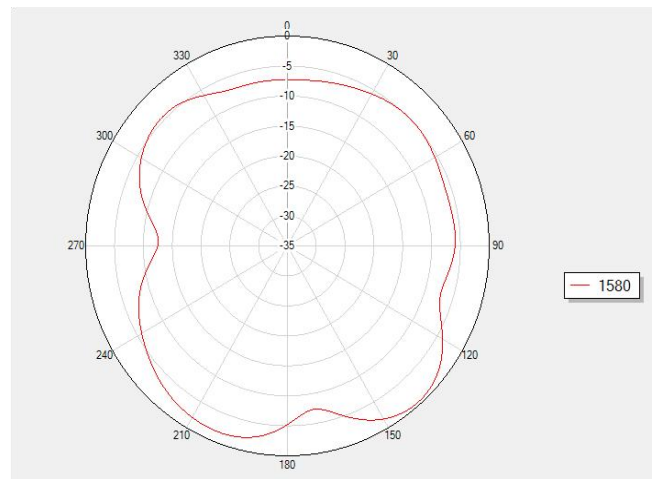
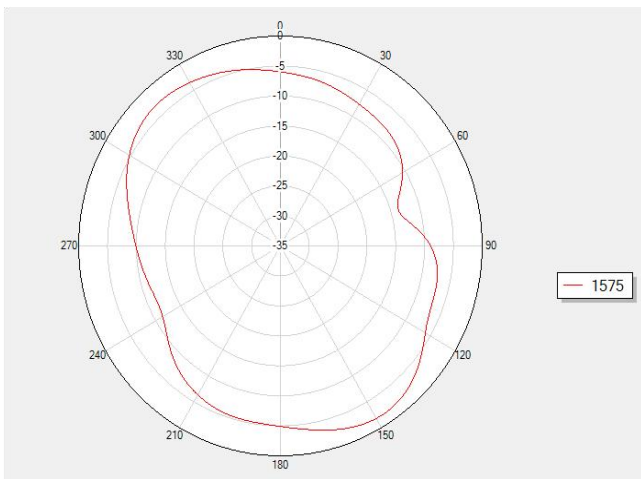
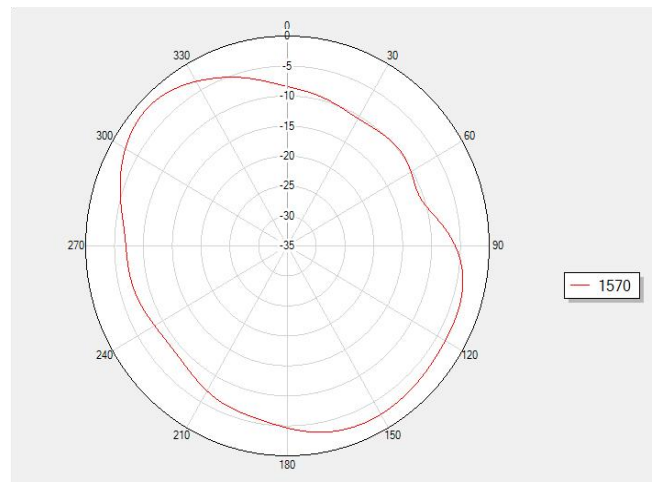
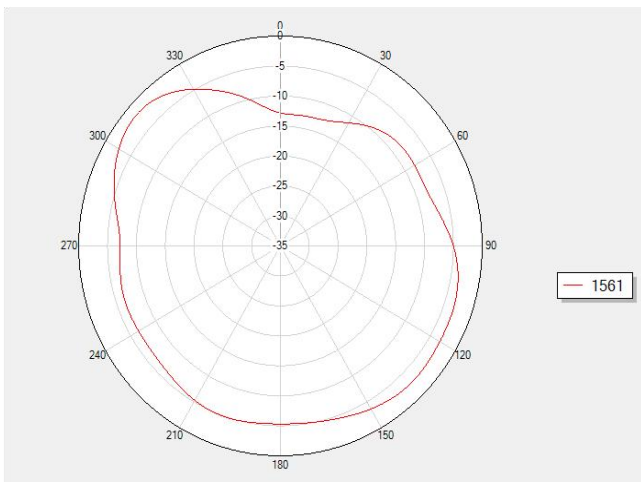



## 7.2 . 3D radiation pattern diagram

Frequency (MHz) : 1561

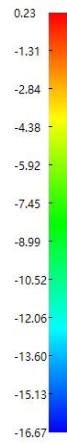
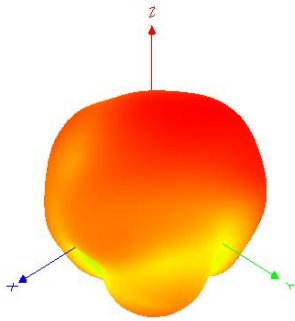

Frequency (MHz) : 1570

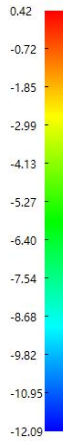
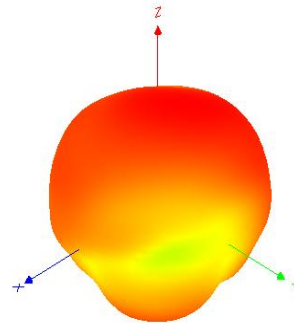

Frequency (MHz) : 1575

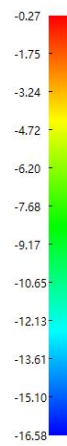
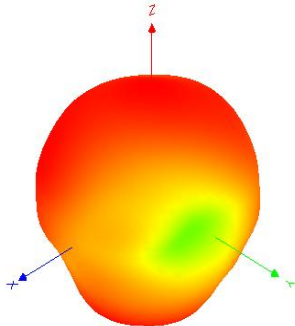

Frequency (MHz) : 1580

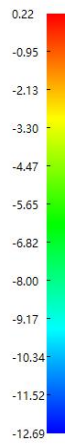
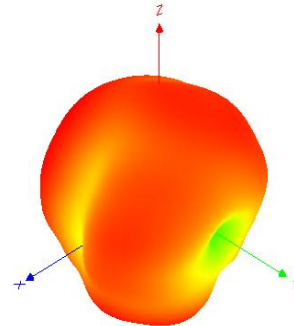



**Documentation**

Version:	July-29-2025-A01
Date:	2025-7-29
Remarks:	Initial release
Author:	Carly

**Change Log**



[www.batwireless.com](http://www.batwireless.com)

Shenzhen Bat Wireless Technology Co., Ltd.

Address: Room 1301, No. 8 Langhua Road, Xinshi Community, Dalang Street, Longhua District, Shenzhen

Email: [marketing@batwireless.com](mailto:marketing@batwireless.com)

Tel: +86-0755-21031236