

客户 (Customer) : _____

承认书

Approval Sheet



谨致执事者：兹提供敝公司之有关详细规格及图面数据, 敬请给予办理试认定手续。
同时敬请送返一份附有贵公司签认之测试认定后之样品承认书。

We are pleased in sending you herewith on specification and drawings for your approval.
Please return to us one copy "Approval sheet" with your approved signature.

型号 (Model No.) : A-SL633W1D-H02-2T

发文日期 (Issue Date) : 2015/10/15 承认日期 (Approved Date) : _____

Checking signature of Amicc

Designer	Checker	Approver
		

Approval signature of customer

Designer	Checker	Approver

江苏欧密格光电科技有限公司

Jiangsu AMICC Opto-Electronics Technology CO., Ltd.

江苏省常州市武进区武南中路 98 号

No. 98, Wu Nan Road, Wujin, Changzhou city, Jiangsu province

TEL:0086-519-89806999

FAX:0086-519-86523668

Flash LED Type

A-SL633W1D-H02-2T



Features

- Top view LED
- High luminous flux output
- Wide viewing angle
- Pb-free
- RoHS compliant

Description

The Amicc 633 package has high efficacy, high power consumption, wide viewing angle and a compact form factor. These features make this package an ideal LED for all lighting applications.

Applications

- General lighting
- Decorative and Entertainment Lighting
- Indicators
- Illumination
- Switch lights
- Flash lights

Device Selection Guide

Chip Materials	Emitted Color	Resin Color
InGaN	White	Yellow Diffused

Absolute Maximum Ratings (T_{Soldering}=25°C)

Parameter	Symbol	Rating	Unit
Forward Current	I _F	180	mA
Peak Forward Current (T=1.3s, tp=0.3s)	I _{FP}	250	mA
Peak Forward Current (T=1000ms, tp=50ms)	I _{FP}	500	mA
Power Dissipation	P _d	1200	mW
Operating Temperature	T _{opr}	-40 ~ +85	°C
Storage Temperature	T _{stg}	-40 ~ +100	°C
Junction Temperature	T _j	115	°C
Soldering Temperature	T _{sol}	Reflow Soldering : 260 °C for 10 sec. Hand Soldering : 350 °C for 3 sec.	

Note:

The products are sensitive to static electricity and must be carefully taken when handling products.

Electro-Optical Characteristics (T_{Soldering}=25°C)

Parameter	Symbol	Min.	Typ.	Max.	Unit	Condition
Luminous Flux	Φ	22	28	36	lm	I _F =60mA
Forward Voltage	V _F	2.75	3.00	3.35	V	I _F =60mA
Viewing Angle	2θ _{1/2}	-----	120	-----	deg	I _F =60mA
Reverse Current	I _R	-----	-----	10	μA	V _R =5V

Notes:

1. Tolerance of Luminous Flux: ±10%.
2. Tolerance of Forward Voltage : ±0.1V.

Bin Range of Luminous Flux

Bin Code	Min.	Max.	Unit	Condition
L31	22	24	lm	$I_F=60\text{mA}$
L32	24	26		
L33	26	28		
L34	28	30		
L35	30	32		
L36	32	34		
L37	34	36		

Note:
Tolerance of Luminous Flux: $\pm 10\%$.

Bin Range of Forward Voltage

Bin Code	Min.	Max.	Unit	Condition
5	2.75	3.05	V	$I_F=60\text{mA}$
6	3.05	3.35		

Note:
Tolerance of Forward Voltage: $\pm 0.1\text{V}$.

Bin Range of Chromaticity Coordinates

Bin Code	CIE_x	CIE_y	Bin Code	CIE_x	CIE_y
E0	0.3284	0.3811	E1	0.3286	0.3690
	0.3493	0.3995		0.3481	0.3856
	0.3481	0.3856		0.3469	0.3717
	0.3286	0.3690		0.3288	0.3569
E2	0.3288	0.3569	D0	0.3124	0.3656
	0.3469	0.3717		0.3284	0.3811
	0.3458	0.3592		0.3286	0.3690
	0.3290	0.3451		0.3136	0.3550
D1	0.3136	0.3550	D2	0.3148	0.3444
	0.3286	0.3690		0.3288	0.3569
	0.3288	0.3569		0.3290	0.3451
	0.3148	0.3444		0.3160	0.3332
D3	0.3160	0.3332	C1	0.3011	0.3422
	0.3290	0.3451		0.3136	0.3550
	0.3292	0.3313		0.3148	0.3444
	0.3175	0.3204		0.3031	0.3327
C2	0.3031	0.3327	C3	0.3052	0.3224
	0.3148	0.3444		0.3160	0.3332
	0.3160	0.3332		0.3175	0.3204
	0.3052	0.3224		0.3076	0.3108

Note:

1. The value is based on driving current by 60mA.
2. Tolerance of Chromaticity Coordinates: ± 0.01

The C.I.E. 1931 Chromaticity Diagram

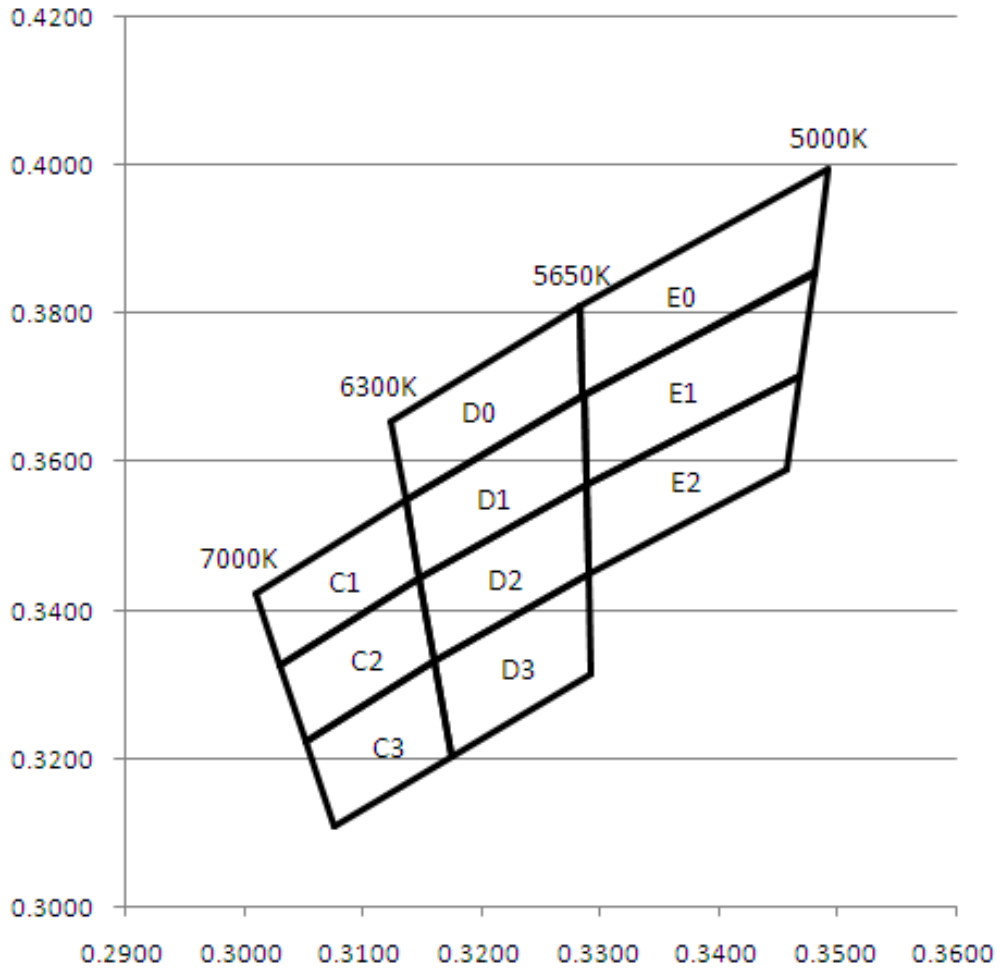

Spectrum Distribution

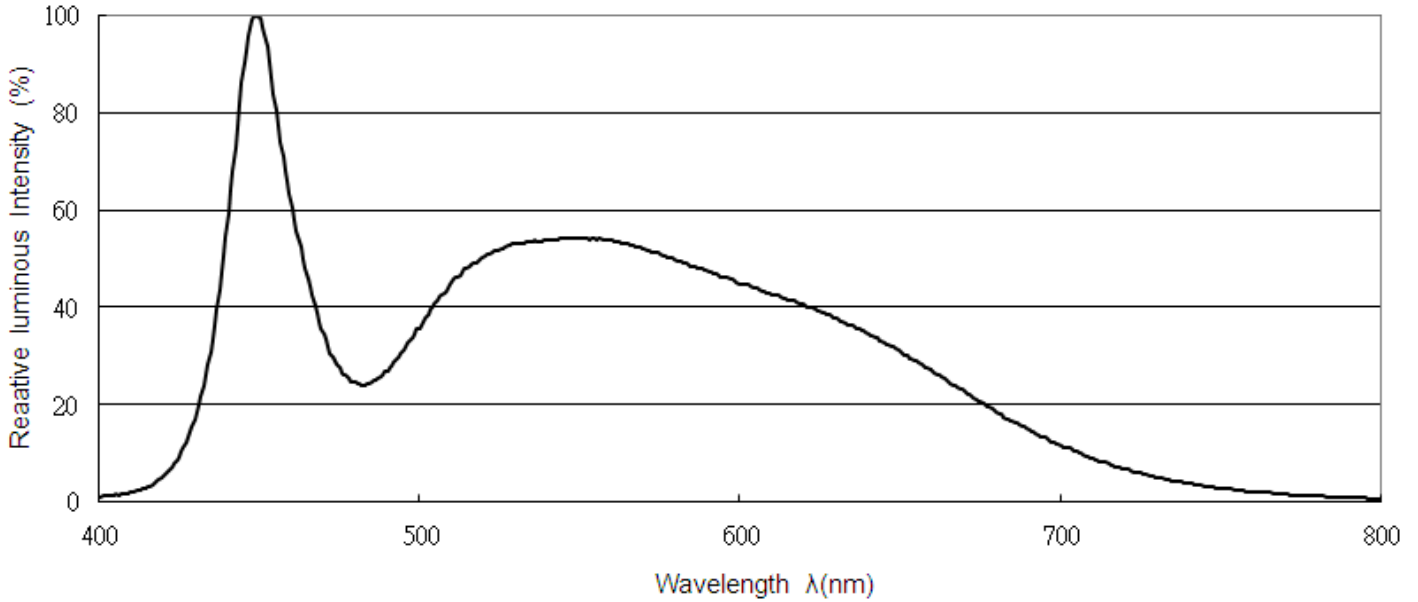

Typical Electro-Optical Characteristics Curves

Fig.1-Forward Voltage Shift vs. Junction Temperature

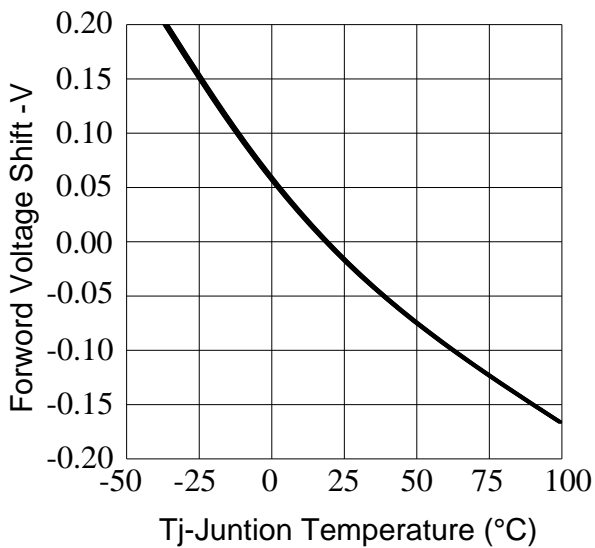
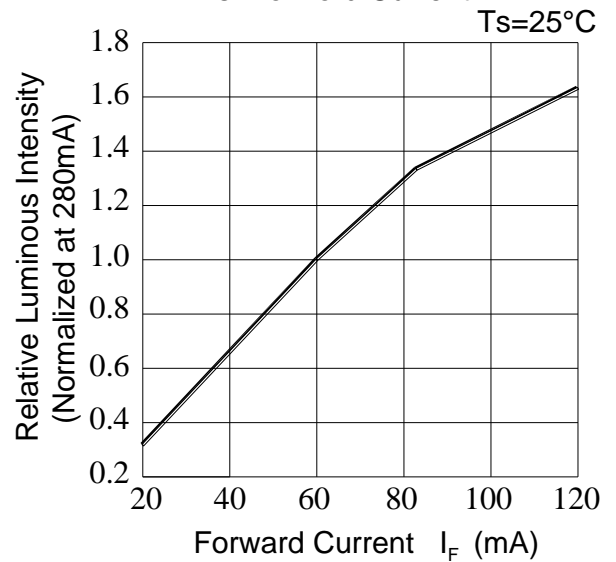

Fig.2-Relative Luminous Intensity vs. Forward Current



Typical Electro-Optical Characteristics Curves

Fig.3-Relative Luminous Intensity vs.Juntion Temperature

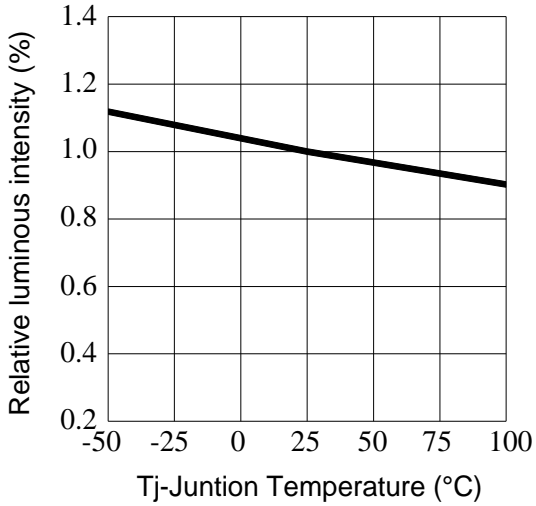

Fig.4-Forward Current vs. Forward Voltage T_a=25°C

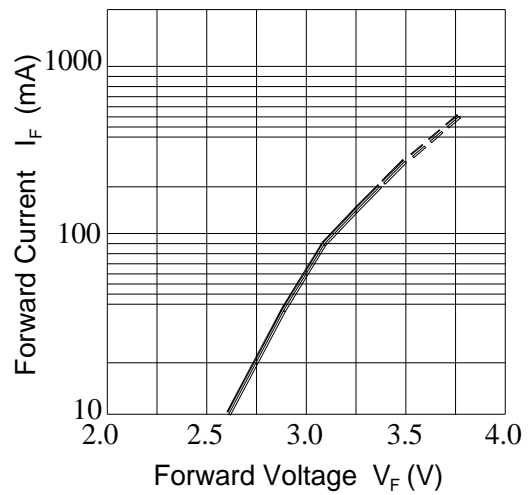

Fig.5-Max.Driving Forward Current vs.Soldering Temperture

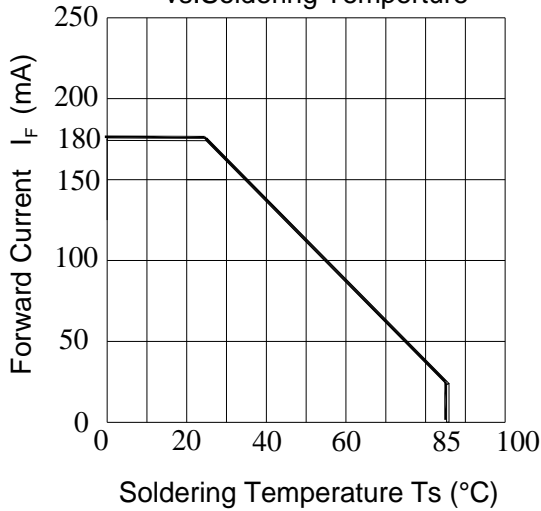
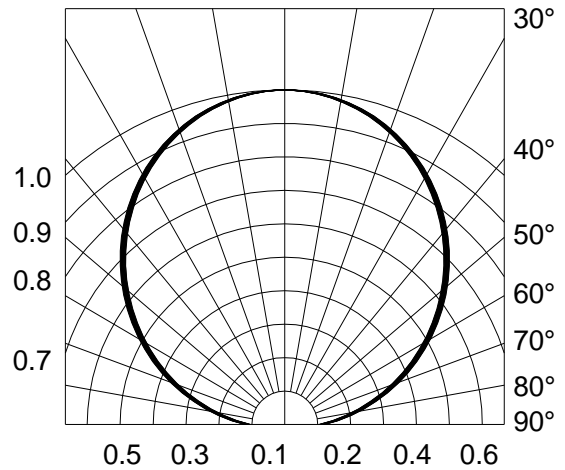
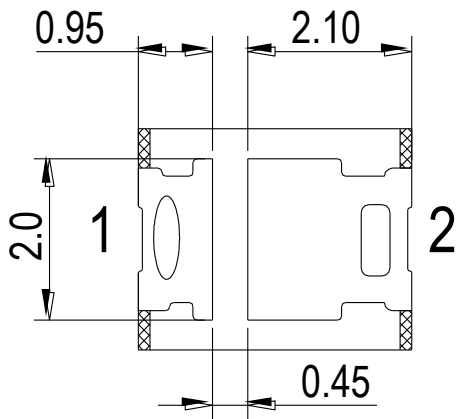
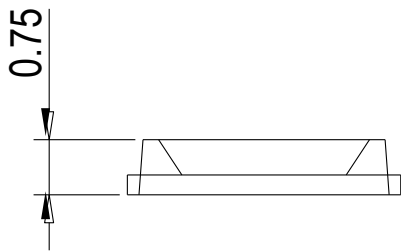
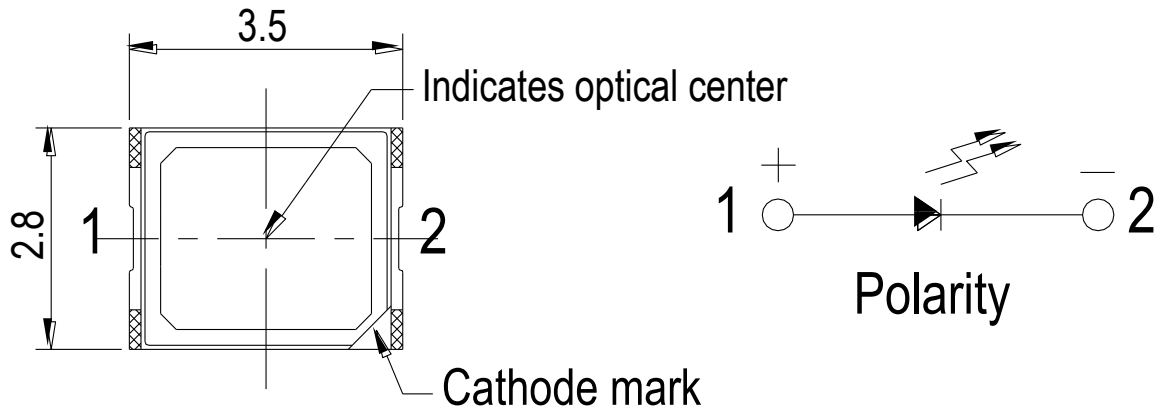

Fig.6-Radiation Diagram T_a=25°C



Package Dimension



Recommended solder pad

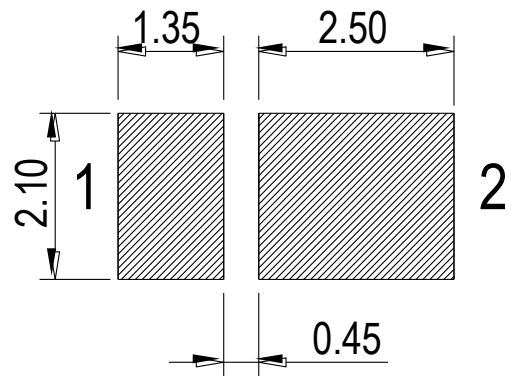

Note:
Tolerance unless mentioned is ± 0.1 mm, Unit = mm.

Moisture Resistant Packing Materials

Label Explanation

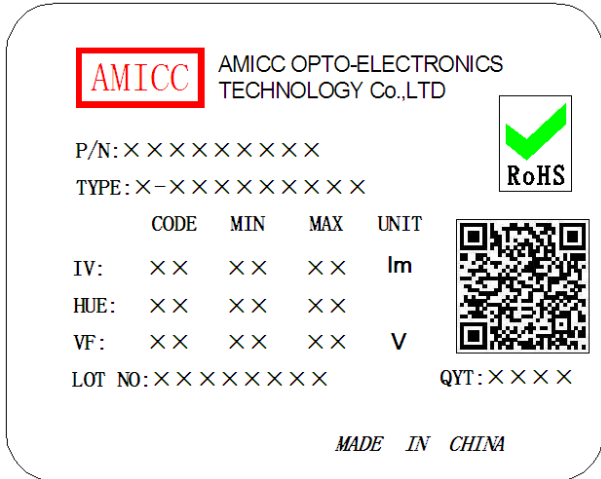

- CPN: Customer's Product Number
- P/N: Product Number
- TYPE :Part NO.
- IV: Luminous Intensity Rank
- HUE: Chromaticity Coordinates Rank
- VF: Forward Voltage Rank
- LOT NO.: Lot Number
- QTY: Packing Quantity

Reel Dimensions

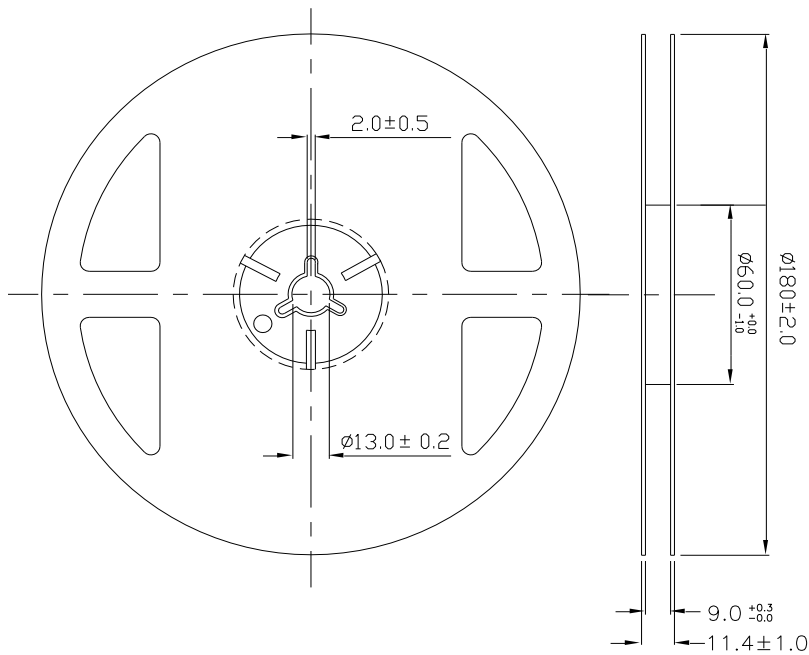

Note:
Tolerances unless mentioned ±0.1mm. Unit = mm.

Carrier Tape Dimensions: Loaded Quantity 2000 pcs Per Reel

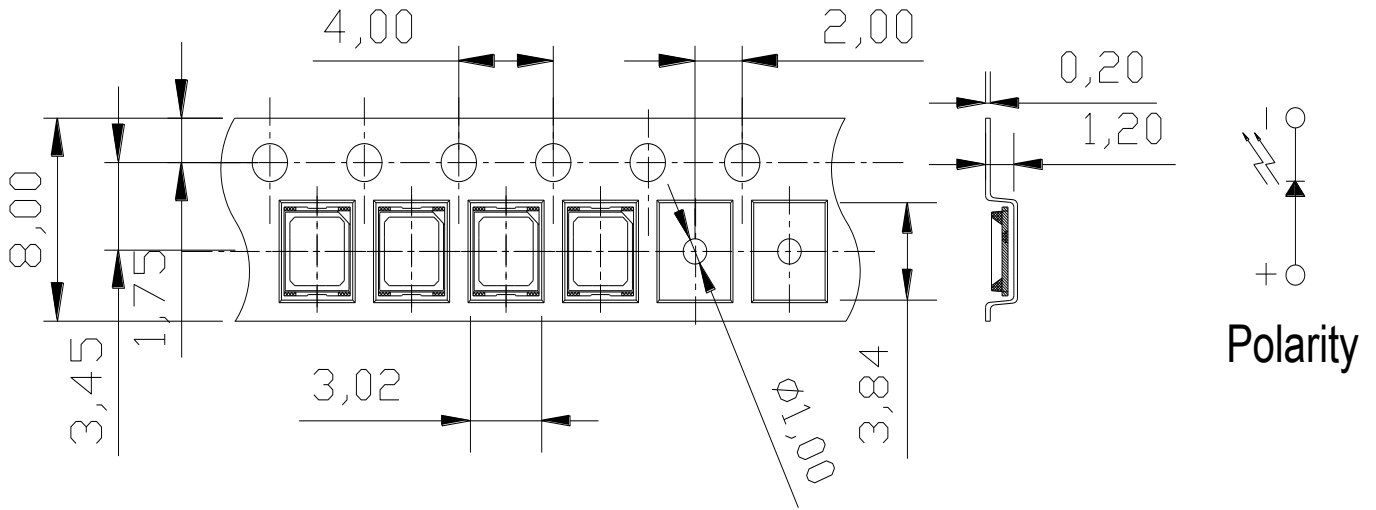

Note:

- 1. Tolerance unless mentioned is ± 0.1 mm, Unit = mm.
- 2. Minimum packing amount is 1000 pcs per reel.

Moisture Resistant Packing Process

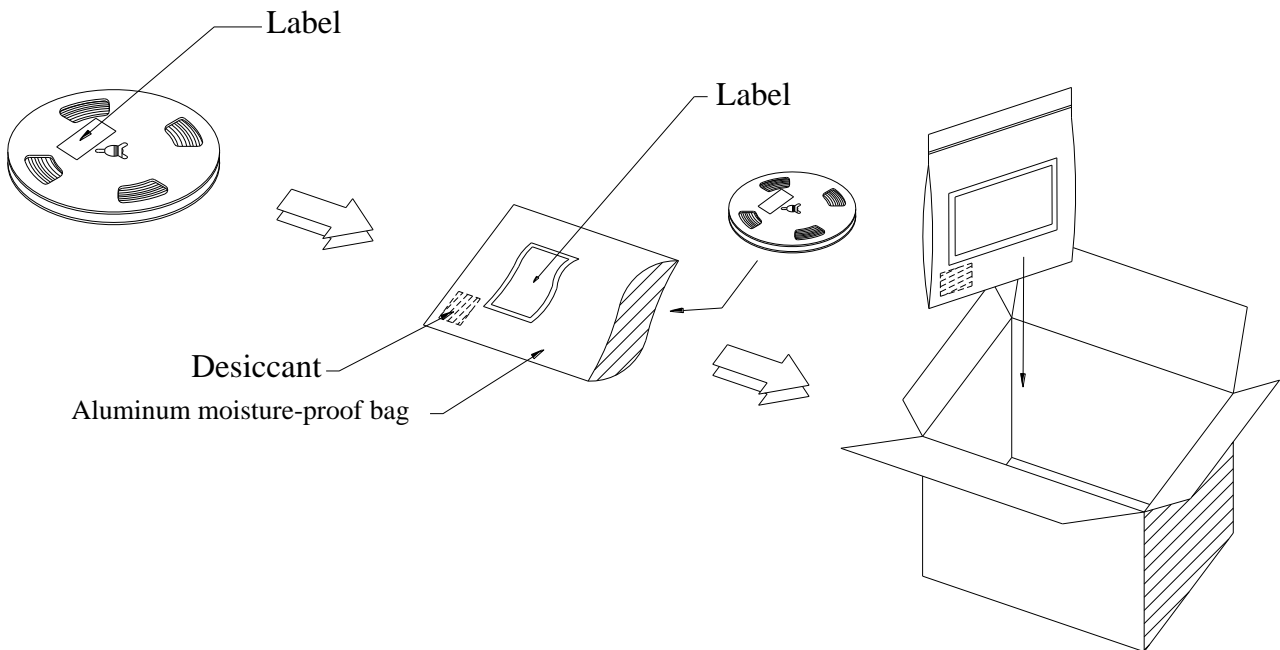

Reliability Test Items and Conditions

The reliability of products shall be satisfied with items listed below.

Confidence level : 90%

LTPD : 10%

No.	Items	Test Condition	Test Hours/Cycles	Sample Size	Ac/Re
1	Reflow Soldering	Temp. : 260°C/10sec.	6 Min.	22 PCS.	0/1
2	Thermal Shock	H : +100°C 5min ∫ 10 sec L : -10°C 5min	300 Cycles	22 PCS.	0/1
3	Temperature Cycle	H : +100°C 15min ∫ 5 min L : -40°C 15min	300 Cycles	22 PCS.	0/1
4	High Temperature/Humidity Reverse Bias	Ta=85°C,85%RH	1000 Hrs.	22 PCS.	0/1
5	Low Temperature Storage	Ta=-40°C	1000 Hrs.	22 PCS.	0/1
6	High Temperature Storage	Ta=100°C	1000 Hrs.	22 PCS.	0/1
7	DC Operation Life	Ta=25°C, I _F = 60 mA	1000 Hrs.	22 PCS.	0/1
8	Peak Forward Current Operation Life (T=1.3s, tp=0.3s)	Ta=25°C, I _{FP} = 250 mA	100000 cycles	5 PCS.	0/1

Precautions for Use

1. Over-current-proof

Customer must apply resistors for protection; otherwise slight voltage shift will cause big current change (Burn out will happen).

2. Storage

2.1 Do not open moisture proof bag before the products are ready to use.

2.2 Before opening the package: The LEDs should be kept at 30°C or less and 90%RH or less.

2.3 After opening the package: The LED's floor life is 168 Hrs under 30°C or less and 60% RH or less. If unused LEDs remain, it should be stored in moisture proof packages.

2.4 If the moisture absorbent material (silica gel) has faded away or the LEDs have exceeded the storage time, baking treatment should be performed using the following conditions.

Baking treatment: 60±5°C for 24 hours.

3. Soldering Condition

3.1 Pb-free solder temperature profile

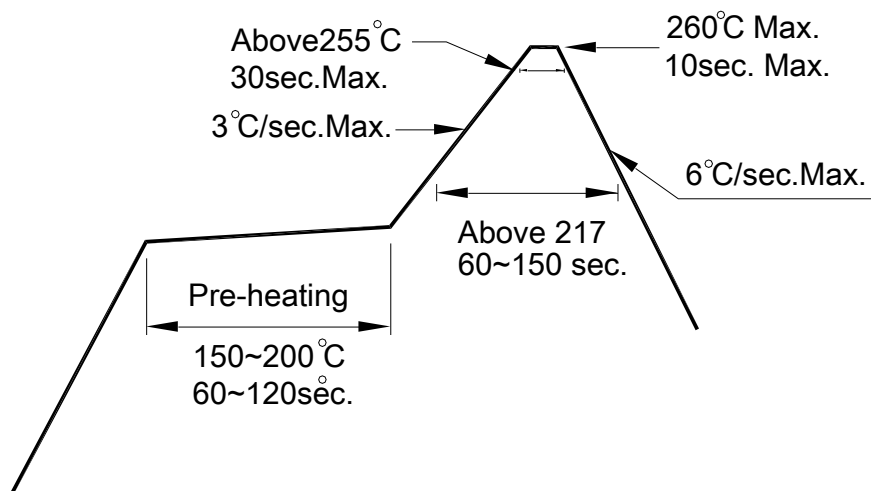

3.2 Reflow soldering should not be done more than two times.

3.3 When soldering, do not put stress on the LEDs during heating.

3.4 After soldering, do not warp the circuit board.

4. Soldering Iron

Each terminal is to go to the tip of soldering iron temperature less than 350°C for 3 seconds within once in less than the soldering iron capacity 25W. Leave two seconds and more intervals, and do soldering of each terminal. Be careful because the damage of the product is often started at the time of the hand solder.

5. Repairing

Repair should not be done after the LEDs have been soldered. When repairing is unavoidable, a double-head soldering iron should be used (as below figure). It should be confirmed beforehand whether the characteristics of the LEDs will or will not be damaged by repairing.