

400V Normally Open (1-Form-A) Optical MOSFET Relay

General Features

- Low-level off State Leakage Current
- No Moving Parts
- Fast Switching Speed
- 1500 Vrms Input/Output Isolation
- SOP Package 4 Pin Type in Miniature Design
- Highly Efficient GaAlAs Infrared LED and Reliability MOSFETs

V_{OFF}	I_{ON}	$R_{ON(TYP.)}$
400V	130mA	14Ω

Applications

- Telecommunications
- Measurement Equipment
- Industrial Automation
- Security Equipment
- Control Equipment
- High Speed Inspection Machine

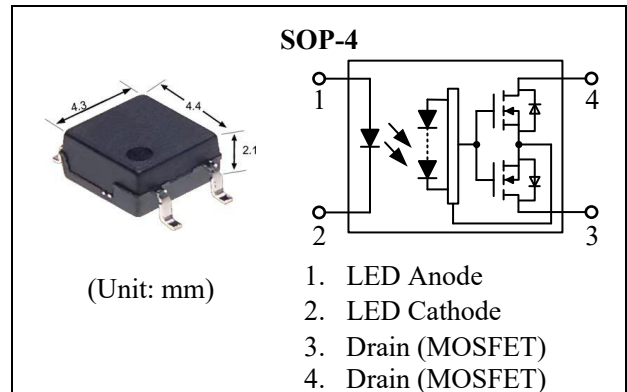

Ordering Information

Part Number	Package	Marking	Packing quantity
OPY214S	SOP-4	OPY214S	2000pcs/Reel

Absolute Maximum Ratings

 $T_a=25^{\circ}\text{C}$ unless otherwise specified

Item		Symbol	Note	Value	Unit
Input	LED Forward Current	I_F	--	50	mA
	LED Pulse Forward Current	I_{FP}	$f=100\text{Hz}$, duty=1%	1000	mA
	LED Reverse Voltage	V_R	--	5	V
	LED Power Dissipation	P_D	--	75	mW
Output	Off-state Output Terminal Voltage	V_{OFF}	AC Peak or DC	400	V
	On-state Current	I_{ON}	--	130	mA
	On-state Peak Current	I_{ONP}	100ms (1 pulse)	300	mA
	Output Power Dissipation	P_O	--	300	mW
Total Power Dissipation		P_T	--	350	mW
Storage Temperature		T_{STG}	--	-40 to 100	$^{\circ}\text{C}$
Operating Temperature		T_{OPR}	--	-40 to 85	$^{\circ}\text{C}$
Soldering Temperature		T_L	10 sec max.	260	$^{\circ}\text{C}$
Isolation Voltage ^[1]		BV_{IO}	AC, RH \leq 60%, 60s	1500	Vrms

Caution: Stresses beyond those listed in the "Absolute Maximum Ratings" may cause permanent damage to the device.

Electrical Characteristics
 $T_a = 25^\circ\text{C}$ unless otherwise specified

Item		Symbol	Min.	Typ.	Max.	Unit	Test Conditions
Input	LED Forward Voltage	V_F	--	1.3	1.4	V	$I_F = 5\text{mA}$
	LED Reverse Current	I_R	--	--	5.0	μA	$V_R = 5\text{V}$
	Trigger LED Current	I_{FT}	--	0.3	3.0	mA	$I_{ON} = 130\text{mA}$
	Return LED Current	I_{FC}	0.05	0.2	--	mA	$I_{OFF} = 100\mu\text{A}$
Output	On-state Resistance ^[2]	R_{ON}	--	14	20	Ω	$I_F = 5\text{mA}, I_{ON} = 130\text{mA}$
	Off-state Leakage Current	I_{OFF}	--	--	100	nA	$V_{OFF} = 400\text{V}$
	Output Capacitance	C_{OUT}	--	65	--	pF	$V_{OFF} = 0\text{V}, f = 1\text{MHz}$
Transmission	Turn-on Time ^[3]	T_{ON}	--	40	100	μs	$I_F = 5\text{mA}, I_{ON} = 130\text{mA}$
	Turn-off Time ^[3]	T_{OFF}	--	20	100	μs	
Coupled	Capacitance Input to Output	C_{IO}	--	0.8	1.5	pF	$V_{IO} = 0\text{V}, f = 1\text{MHz}$
	Isolation Resistance	R_{IO}	10^{10}	--	--	Ω	DC = 500V
	Isolation Voltage	BV_{IO}	1500	--	--	Vrms	AC, 60s

NOTE:

[1] LED pins are shorted together. Detector pins are also shorted together.

[2] Measurement Taken within 1 Second of On-time.

[3] Switching Time Test Circuit:

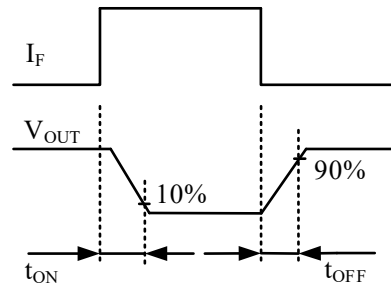
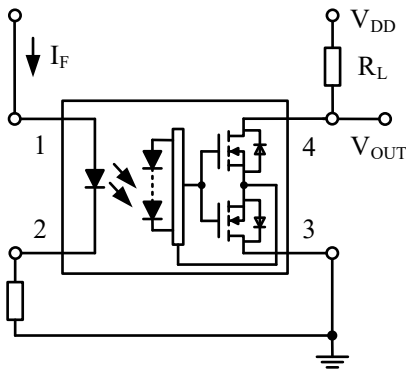

Typical Device Performance

Figure 1. Load Current vs. Ambient Temperature

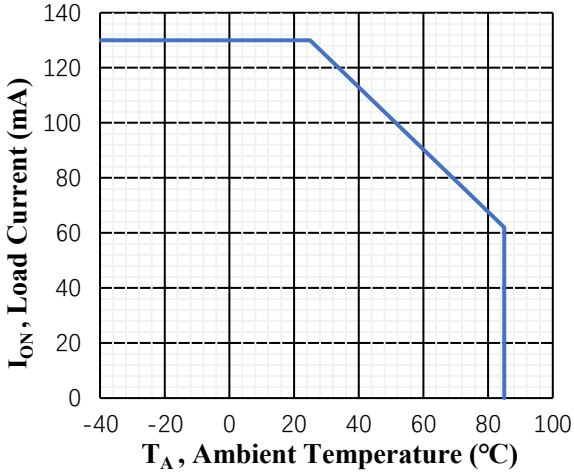

Figure 2. On-state Resistance vs. Ambient Temperature

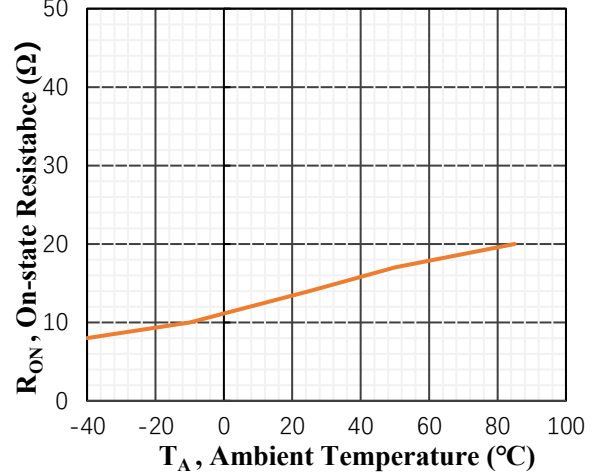

Figure 3. Switching Time vs. Ambient Temperature

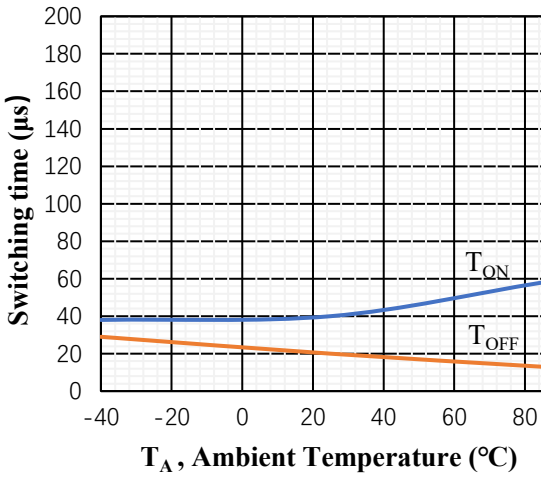

Figure 4. Trigger LED Current vs. Ambient Temperature

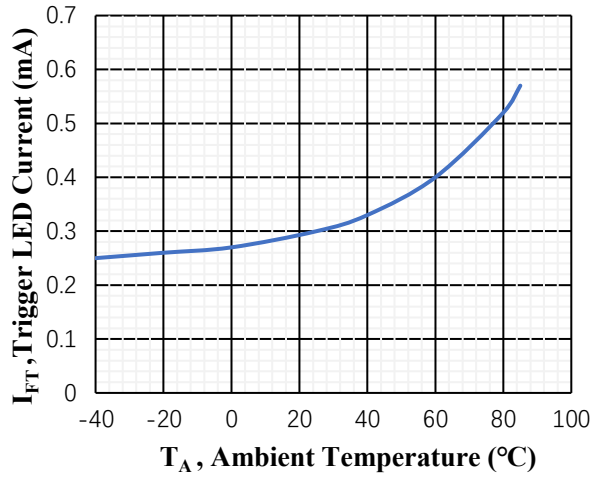

Figure 5. LED forward Voltage Vs. Ambient Temperature

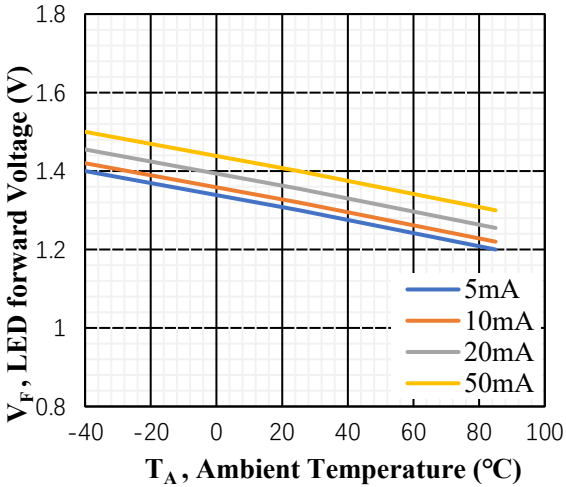
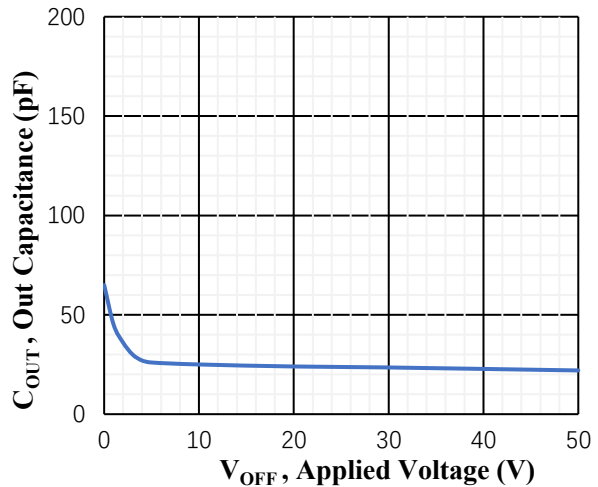
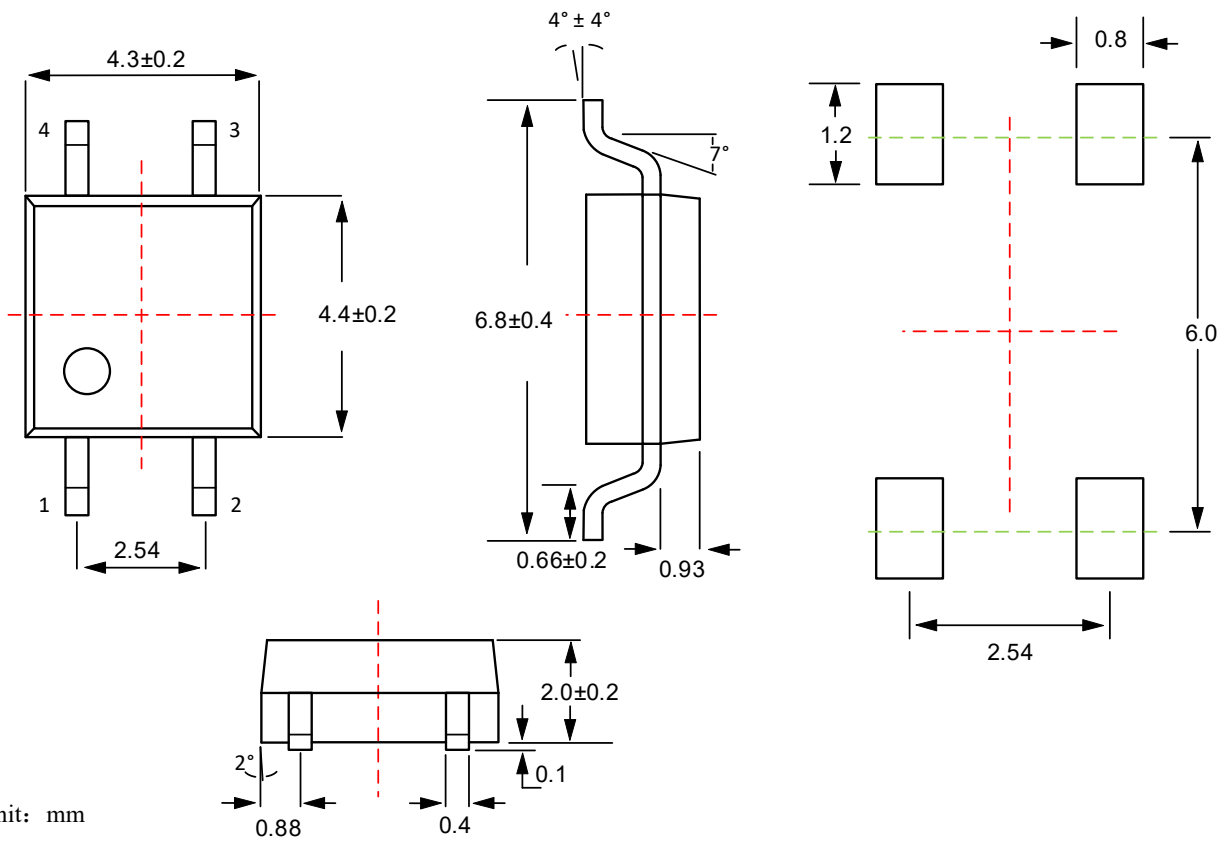

Figure 6. Output Capacitance Vs. Applied Voltage



Package Dimensions

SOP - 4



Published by**ARK Microelectronics Co., Ltd.****Add: D26, UESTC National Science Park, No. 1 Shuangxing Avenue, Chengdu, Sichuan****Tel: +86 (028) 8523-2215****Email: sales@ark-micro.com****Website: www.ark-micro.com****All Rights Reserved.**

Disclaimers

ARK Microelectronics Co., Ltd. reserves the right to make change without notice in order to improve reliability, function or design and to discontinue any product or service without notice. Customers should obtain the latest relevant information before orders and should verify that such information is current and complete. All products are sold subject to ARK Microelectronics Co., Ltd.'s terms and conditions supplied at the time of order acknowledgement.

ARK Microelectronics Co., Ltd. warrants performance of its hardware products to the specifications at the time of sale, Testing, reliability and quality control are used to the extent ARK Microelectronics Co., Ltd deems necessary to support this warrantee. Except where agreed upon by contractual agreement, testing of all parameters of each product is not necessary performed.

ARK Microelectronics Co., Ltd. does not assume any liability arising from the use of any product or circuit designs described herein. Customers are responsible for their products and applications using ARK Microelectronics Co., Ltd.'s components. To minimize risk, customers must provide adequate design and operating safeguards.

ARK Microelectronics Co., Ltd. does not warrant or convey any license either expressed or implied under its patent rights, nor the rights of others. Reproduction of information in ARK Microelectronics Co., Ltd.'s data sheets or data books is permissible only if reproduction is without modification or alteration. Reproduction of this information with any alteration is an unfair and deceptive business practice. ARK Microelectronics Co., Ltd. is not responsible or liable for such altered documentation.

Resale of ARK Microelectronics Co., Ltd.'s products with statements different from or beyond the parameters stated by ARK Microelectronics Co., Ltd. for the product or service voids all express or implied warranties for the associated ARK Microelectronics Co., Ltd.'s product or service and is unfair and deceptive business practice. ARK Microelectronics Co., Ltd. is not responsible or liable for any such statements.

Life Support Policy:

ARK Microelectronics Co., Ltd.'s products are not authorized for use as critical components in life support devices or systems without the express written approval of ARK Microelectronics Co., Ltd.

As used herein:

1. Life support devices or systems are devices or systems which:
 - a. Are intended for surgical implant into the human body,
 - b. Support or sustain life, or
 - c. When used in accordance with instructions provided in their labeling, whose failure to perform can be reasonably expected to result in significant injury to the patient.
 2. A critical component is any component of a life support device or system whose failure to perform can be reasonably expected to:
 - a. Cause the failure of the life support device or system, or
 - b. Affect its safety or effectiveness.
-