

标记 MARK	ECN编号/变更内容 ECN NO/DEFINITION				修改 REVISE	日期 DATE	核准 APPROVE			
	CKI	DIM A	DIM B	DIM C	DIM D	CKI	DIM A	DIM B	DIM C	DIM D
	4	1.50	2.56	7.60		33	16.00	17.06	22.10	5.2
	5	2.00	3.06	8.10		34	16.50	17.56	22.60	
	6	2.50	3.56	8.60		35	17.00	18.06	23.10	
	7	3.00	4.06	9.10		36	17.50	18.56	23.60	
	8	3.50	4.56	9.60		37	18.00	19.06	24.10	
	9	4.00	5.06	10.10		38	18.50	19.56	24.60	
	10	4.50	5.56	10.60		39	19.00	20.06	25.10	
	11	5.00	6.06	11.10		40	19.50	20.56	25.60	
	12	5.50	6.56	11.60		41	20.00	21.06	26.10	
	13	6.00	7.06	12.10		42	20.50	21.56	26.60	
	14	6.50	7.56	12.60		43	21.00	22.06	27.10	
	15	7.00	8.06	13.10		44	21.50	22.56	27.60	
	16	7.50	8.56	13.60		45	22.00	23.06	28.10	
	17	8.00	9.06	14.10		46	22.50	23.56	28.60	
	18	8.50	9.56	14.60	5.2	47	23.00	24.06	29.10	5.8
	19	9.00	10.06	15.10		48	23.50	24.56	29.60	
	20	9.50	10.56	15.60		49	24.00	25.06	30.10	
	21	10.00	11.06	16.10		50	24.50	25.56	30.60	
	22	10.50	11.56	16.60		51	25.00	26.06	31.10	
	23	11.00	12.06	17.10		52	25.50	26.56	31.60	
	24	11.50	12.56	17.60		53	26.00	27.06	32.10	
	25	12.00	13.06	18.10		54	26.50	27.56	32.60	
	26	12.50	13.56	18.60		55	27.00	28.06	33.10	
	27	13.00	14.06	19.10		56	27.50	28.56	33.60	
	28	13.50	14.56	19.60		57	28.00	29.06	34.10	
	29	14.00	15.06	20.10		58	28.50	29.56	34.60	
	30	14.50	15.56	20.60		59	29.00	30.06	35.10	
	31	15.00	16.06	21.10		60	29.50	30.56	35.60	
	32	15.50	16.56	21.60						

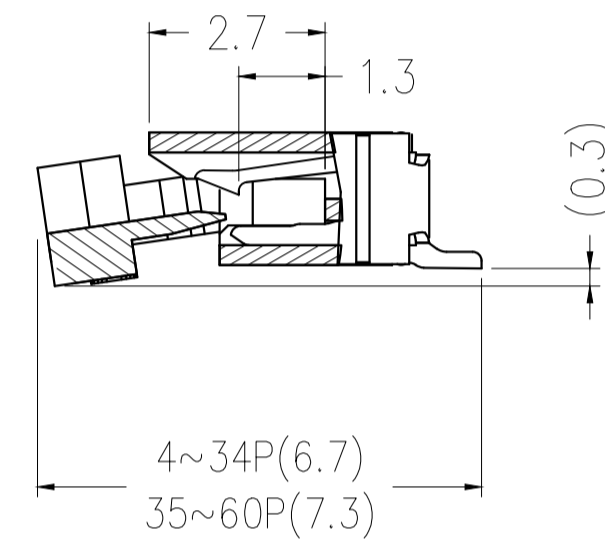

SECTION A-A

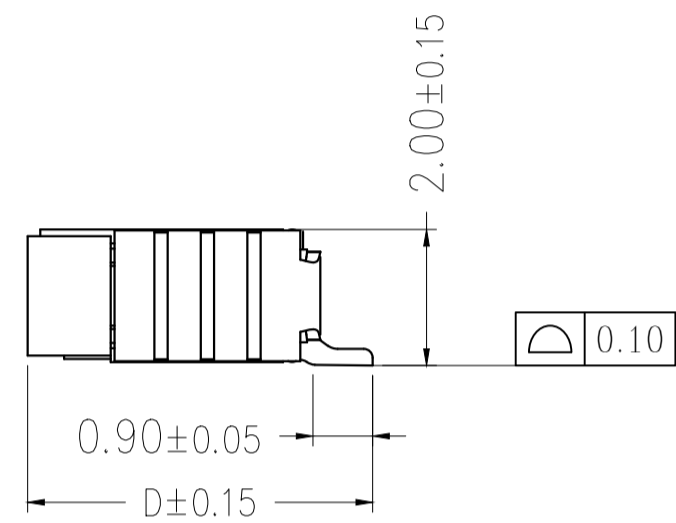
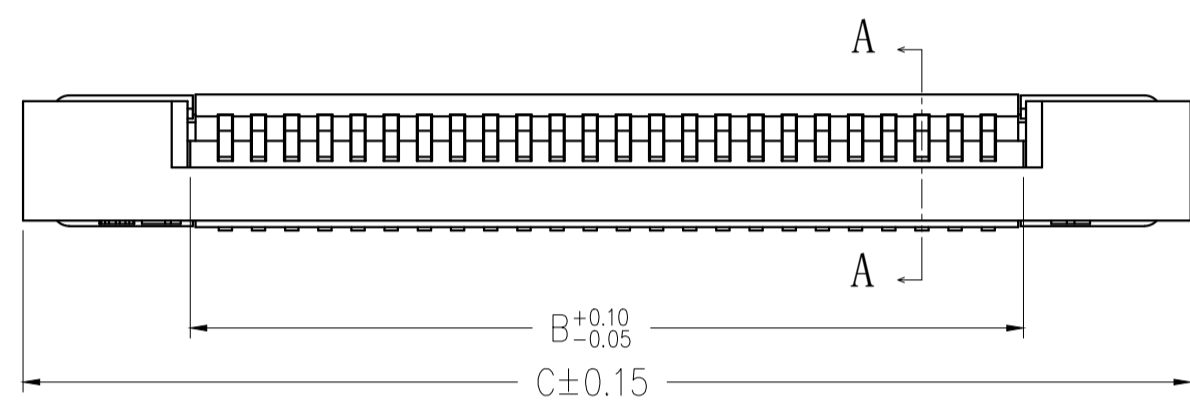
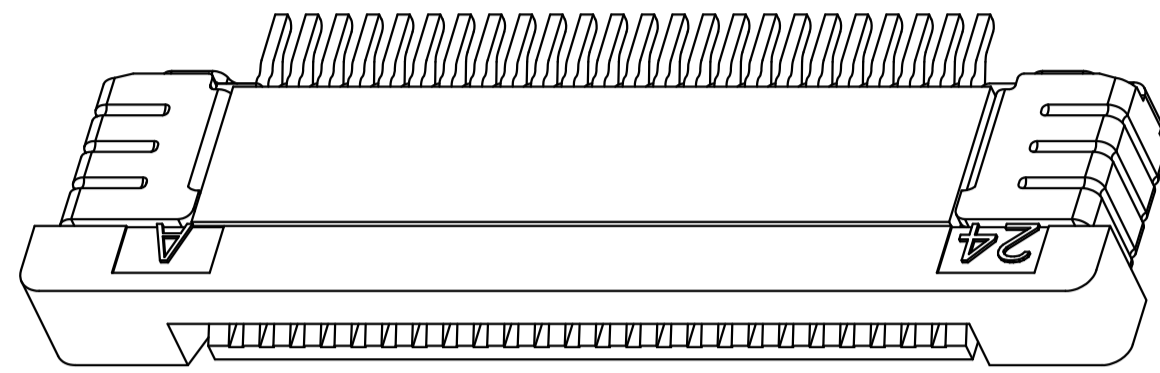
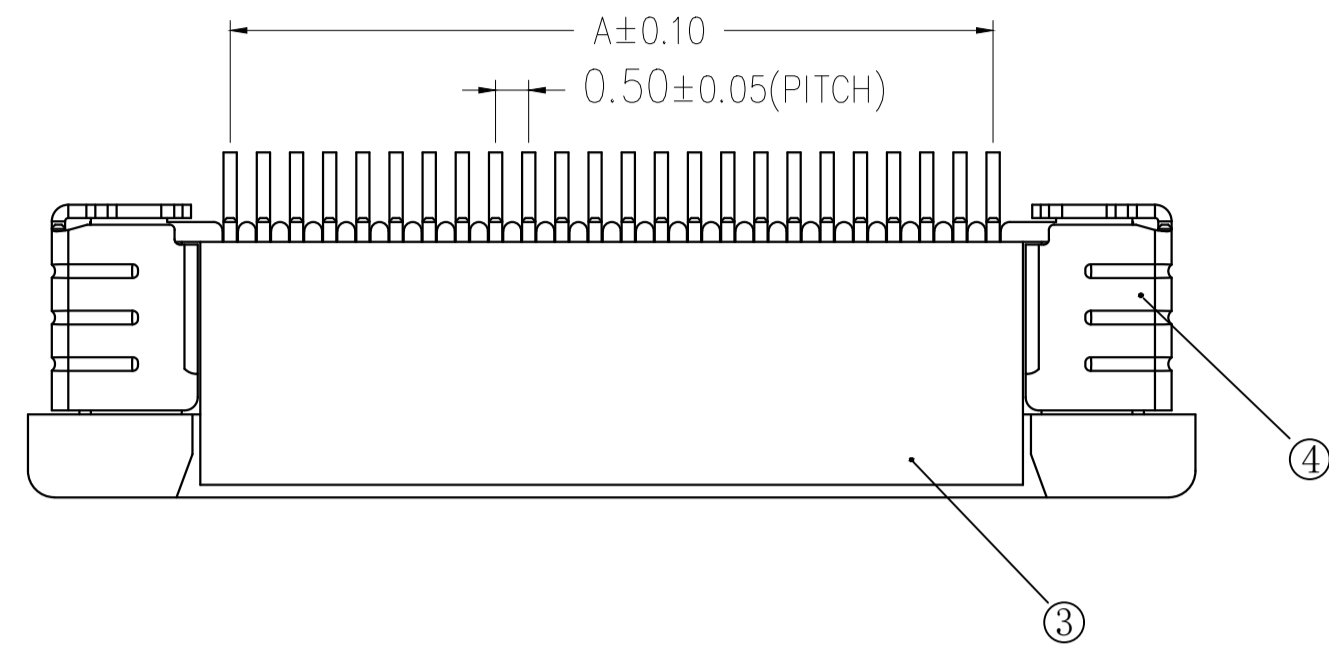
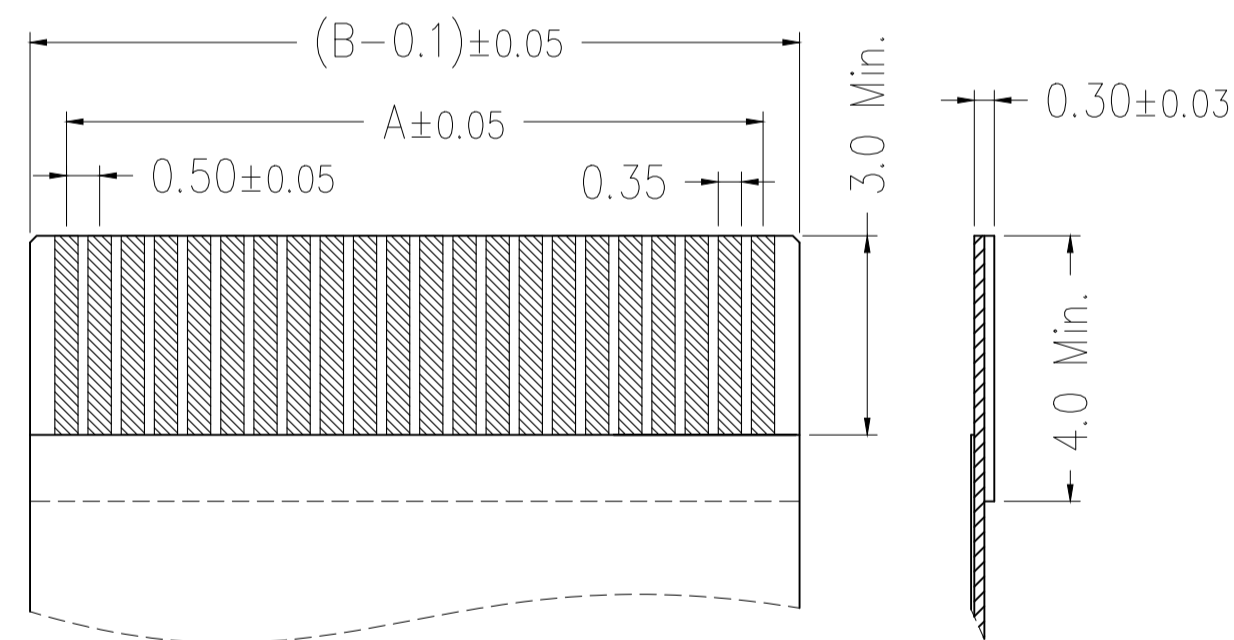
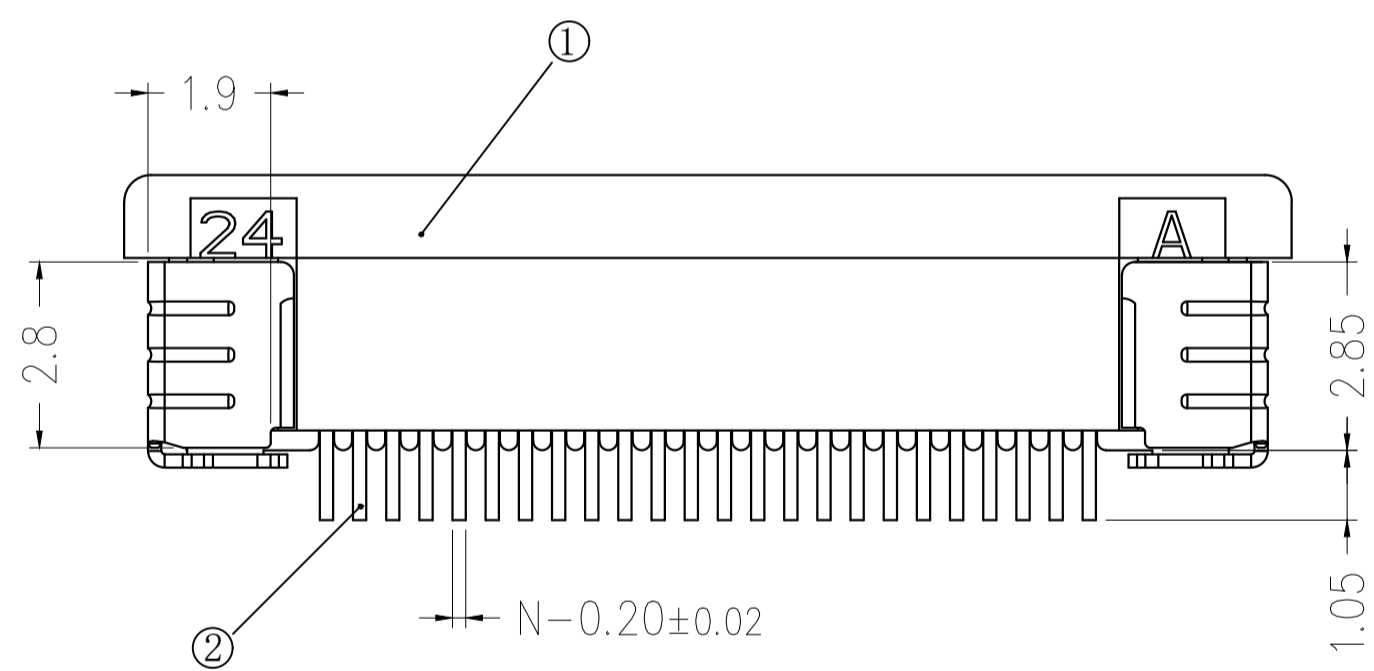

适用扁平线 (Applicable Flat Cable)

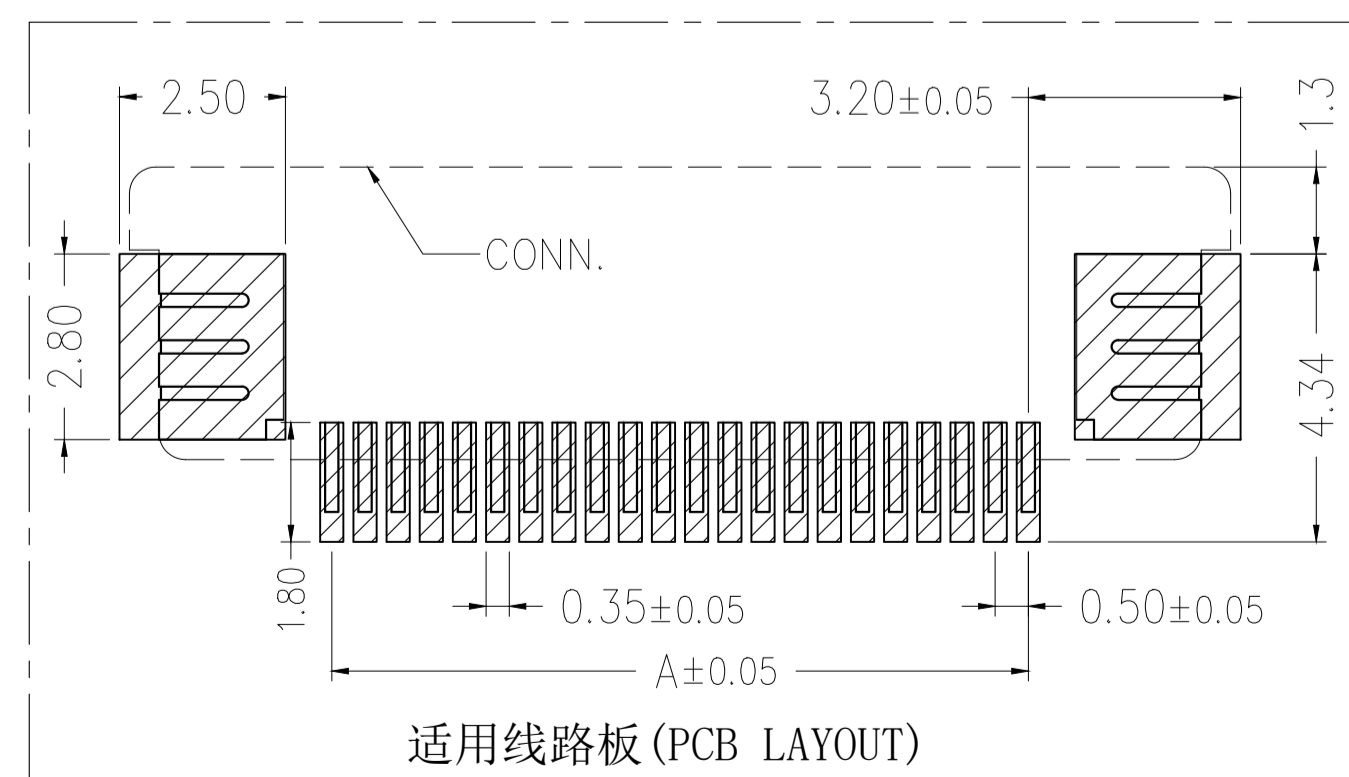

适用线路板 (PCB LAYOUT)

技术指标 (Technical Index):

1. 塑件表面应光洁、无毛边、无明显收缩、缺陷、裂纹等现象。(The surface of the plastic parts should be smooth, no rough edges, no obvious shrinkage, defects, cracks and other phenomena.)
2. 温度范围 (Temperature range): $-25^{\circ}\text{C} \sim +85^{\circ}\text{C}$.
3. 额定电压 (Rated voltage): 50V, AC/DC (=等效).
4. 接触电阻 (Contact resistance): $\leq 0.03\Omega$.
5. 绝缘电阻 (Insulation resistance): $\geq 500\Omega$.

2	端子	铜	镀锡	
1	胶芯	LCP	黑色	
序号	品名	材质	电镀/颜色	备注

	深圳市虹成电子有限公司 GENERAL TOLERANCES (UNLESS SPECIFIED)		品名 TITLE FPC座	
	料号 PART NO HC-FPC-0.5-45P-CSH20			
X. ±.50 .XX ±.10 .X ±.20 .XXX ±.05 ANGLES ±1°	比列 SCALE 1:1	单位 UNIT MM	制图 DRAW AhYe	张数 PART NO 1 OF 1
	版本 REV A	审核 CHECKED 夏操云	批准 APPROVE 赵亮亮	