

GENERAL DESCRIPTION

The GS2302D Series is a low drop-out voltage regulator that features high accurate, high ripple rejection, low power consumption with enable and soft-start function.

The current limiter's fold-back circuit operates as a short circuit protection as well as the output current limiter for the output pin.

Output voltage is selectable from 0.8V to 5.0V which fixed by laser trimming technologies, Step=100mV.

The GS2302D Series is available in SOT23-5 packages.

FEATURES

- Output Accuracy: $\pm 1.5\%$
- Low Quiescent Current: 40uA
- Low Dropout Voltage: 42mV@100mA
- High PSRR: 95dB@1KHz,1mA
- ESD Rating(HBM): $\pm 4KV$
- Output Current: 300mA
- Excellent Line and Load Transient Regulation
- Operating Voltage Range: from 1.5V to 6.0V
- Output Voltage Range: from 0.8V to 5.0V
- Soft-Start Function
- Over-Temperature Protection
- Current Limiting Protection
- Output Short-Circuit Protection
- Available in SOT23-5 Packages

APPLICATIONS

- Battery-Powered Devices
- Reference Voltage Sources
- Other Low Voltage Power Suppliers

PIN DESCRIPTION:

SYMBOL		DESCRIPTION
Pin	SOT23-5	
VIN	1	Power Supply Input
GND	2	Ground
EN	3	Chip Enable
NC	4	Not Connected
VOUT	5	Output

PIN ASSIGNMENT

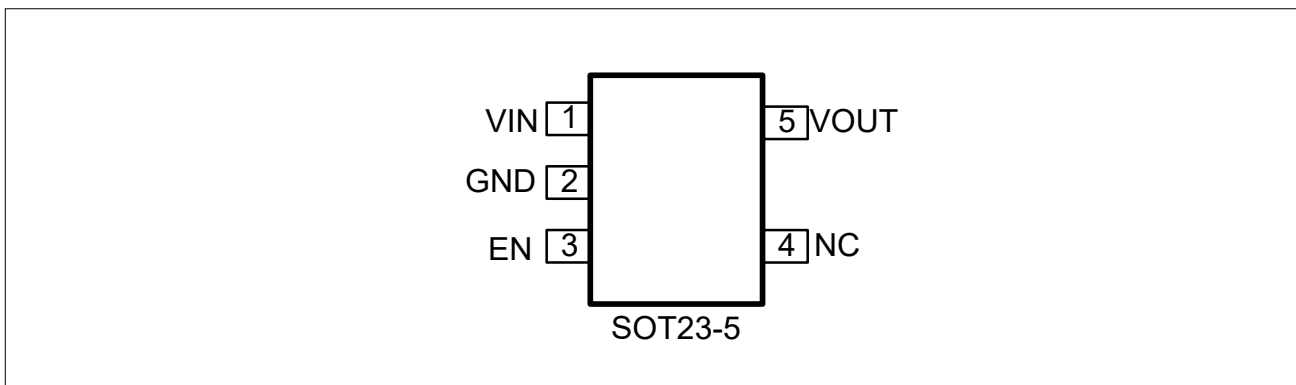

Order Information

Model	PIN-Package	Ordering Number	Packing Option
GS2302D	SOT23-5	GS2302D-XXTR5	3000pcs/Reel

Note:“XX”represents the type of voltage value.

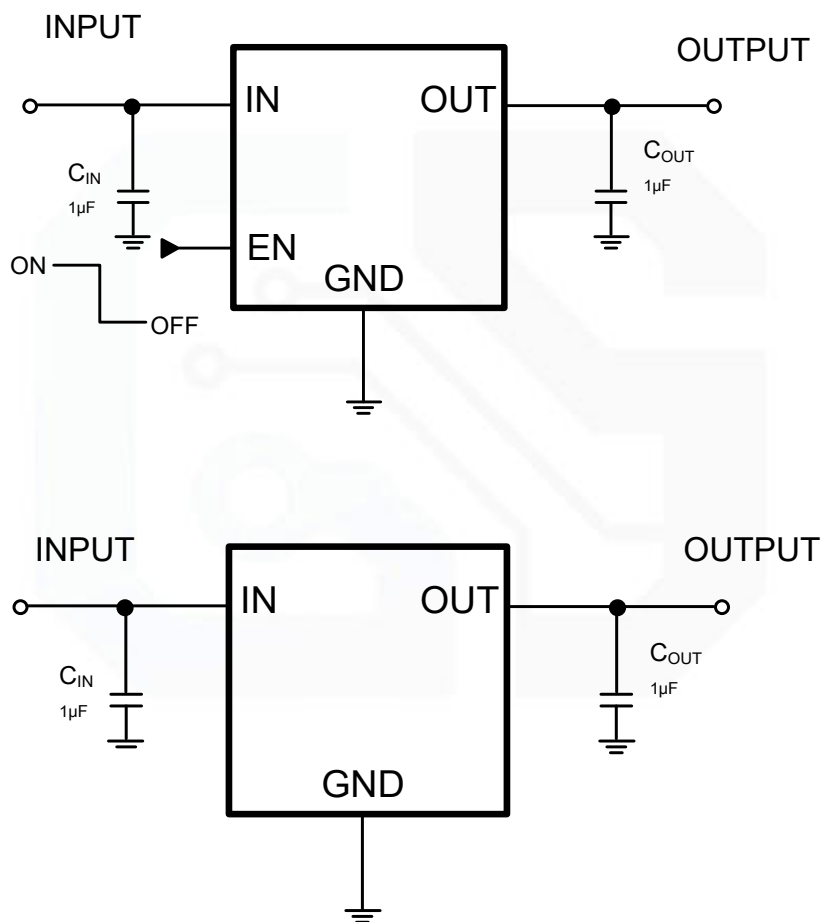
TYPICAL APPLICATION CIRCUIT

ABSOLUTE MAXIMUM RATINGS (Note 1):

Symbol	Item		Rating	Unit
V _{IN}	Supply Voltage		-0.3~7.0	V
V _{EN}	EN Pin Voltage		-0.3~7.0	V
V _{OUT}	V _{OUT} pin Voltage		-0.3~ (V _{IN} +0.3)	V
V _(ESD)	ESD Susceptibility, Human-body model ⁽²⁾		+/-4000	V
PD	Maximum Power Dissipation	SOT23-5	438	mW
PTR	Package Thermal Resistance Θ_{JA} ⁽³⁾	SOT23-5	285	°C/W
T _J	Junction Temperature Range		-40~150	°C
T _{STG}	Storage Temperature Range		-40~150	°C
T _{SOLDER}	Lead Temperature (Soldering, 10 Sec)		260	°C

Note:

1: Absolute Maximum Ratings are threshold limit values that must not be exceeded even for an instant under any condition. Moreover, such values for any two items must not be reached simultaneously. Operation above these absolute maximum ratings may cause degradation or permanent damage to the device. These are stress ratings only and do not necessarily imply functional operation below these limits.

2: per ANSI/ESDA/JEDEC JS-001

3: Device mounted on FR-4 PCB

RECOMMENDED OPERATING RANGE:

Symbol	Item		Rating	Unit
V _{IN}	VIN Supply Voltage		1.5~6.0	V
V _{EN}	EN Pin Voltage		0~6.0	V
V _{OUT}	V _{OUT} pin Voltage		0.8~5.0	V
I _{OUT}	Output Current		0~300	mA
T _{SOLDER}	Junction Temperature Range (Soldering, 10 Sec)		-40~125	°C

ELECTRICAL CHARACTERISTICS:

 (V_{IN}=V_{OUT}+1V, V_{OUT}=3.3V, C_{IN}= C_{OUT}=1uF, T_A =25℃, unless otherwise specified.)

Symbol	Parameter	Conditions	MIN	TYP	MAX	Units
V _{IN}	Input Voltage		1.5		6.0	V
V _{OUT}	Output Accuracy	I _{OUT} = 1mA	-1.5		+1.5	%
I _{LIM}	Current Limit ⁽¹⁾	V _{IN} = 4.3V, V _{OUT} = 3.3V	310	380		mA
I _Q	Quiescent Current	V _{IN} = V _{EN} =V _{OUT} +1V, No Load		40	60	μA
I _{SHD}	Shutdown Current	V _{IN} =6.0V, V _{EN} =0V			0.1	μA
V _{DROP}	Dropout Voltage ⁽²⁾	I _{OUT} =100mA, V _{OUT} = 3.3V		42		mV
		I _{OUT} =200mA, V _{OUT} = 3.3V		85		
		I _{OUT} =300mA, V _{OUT} = 3.3V		130		
S _{LINE}	Line Regulation	V _{IN} = V _{OUT} +1.0V to 6.0V, I _{OUT} =1mA		0.06	0.13	%/V
S _{LOAD}	Load Regulation	1mA≤I _{OUT} ≤300mA		0.001	0.01	%/mA
I _{SHORT}	Short Current	V _{OUT} =0V		40		mA
V _{ENH}	EN High Voltage	V _{IN} =1.5V to 6.0V, I _{OUT} =1mA	1.5			V
V _{ENL}	EN Low Voltage				0.5	V
PSRR	Power Supply Rejection Ratio	C _{IN} =None, V _{OUT} =3.3V I _{OUT} =1mA	f=217Hz		93	dB
			f=1KHz		95	
			f=10KHz		73	
T _{SD}	Thermal Shutdown	temperature rising		155		℃
Δ T _{SD}	TSD Hysteresis	Temperature falling		20		℃
R _{DISCHRG}	R _{ON} of Discharge MOSFET	V _{IN} = V _{OUT} +1V, V _{EN} =0V		200		Ω
I _{RUSH}	Inrush Current	V _{IN} =5.0V, No Load		180		mA

Notes:

1. Guaranteed by design
2. The dropout voltage is defined as V_{IN} - V_{OUT}, when V_{OUT} =95%*V_{OUT(NOW)}.

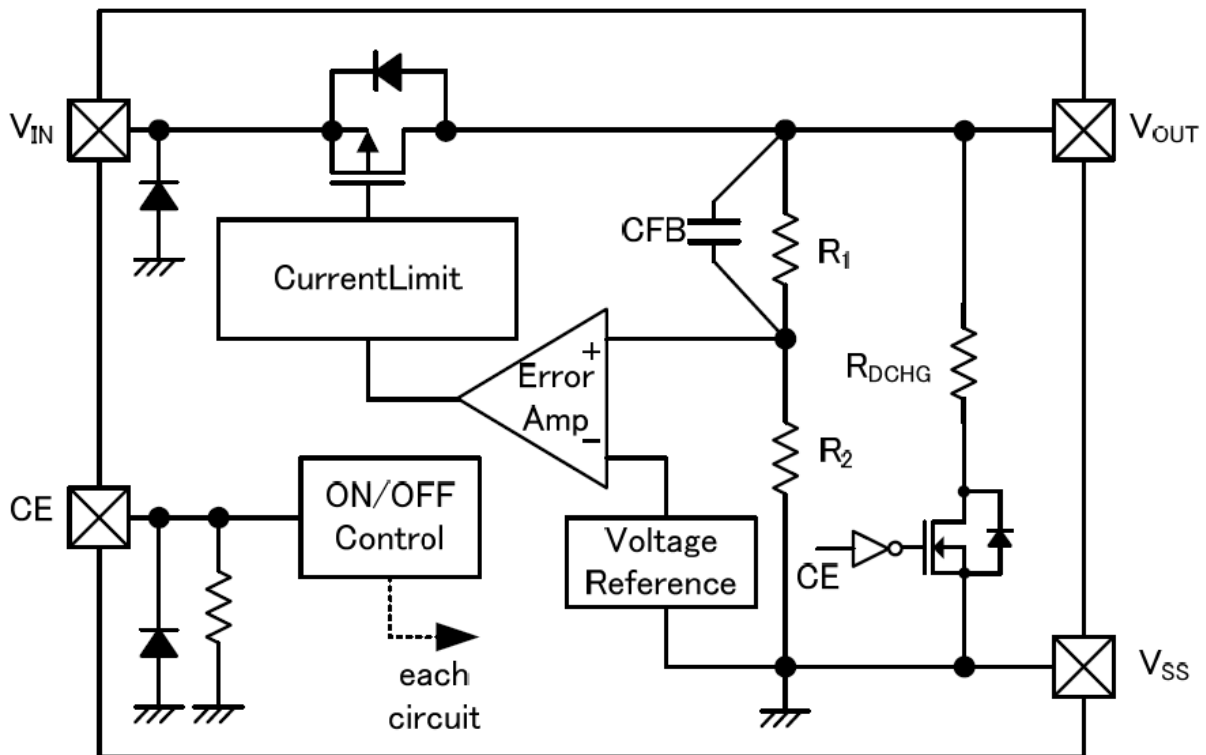
SIMPLIFIED BLOCK DIAGRAM:

DETAIL OPERATION DESCRIPTION:

The GS2302D Series is a low power consumption low drop-out voltage regulator. It consists of a current limiter circuit, a driver transistor, a precision voltage reference and an error correction circuit, and is compatible with low ESR ceramic capacitors. The current limiter's fold-back circuit operates as a short circuit protection as well as the output current limiter. The GS2302D Series built-in soft-start circuit limits the inrush current at start-up. During approximate 70 μ s after the EN pin becomes high, the inrush current, which occurs at charging the capacitor of COUT, is limited at about 180mA.

Current Limiting and Short-Circuit Protection

The current limit circuitry prevents damage to the MOSFET switch and the hub downstream port but can deliver load current up to the current limit threshold of typically 700mA through the switch. When a heavy load or short circuit is applied to an enabled switch, a large transient current may flow until the current limit circuitry responds. Once this current limit threshold is exceeded the device enters constant current mode until the thermal shutdown occurs or the fault is removed.

TYPICAL OPERATING CHARACTERISTICS:

(Tested under $T_J = 25^\circ\text{C}$, unless otherwise specified)

1. V_{OUT} vs T_J

($V_{IN}=4.3\text{V}$, $V_{OUT}=3.3\text{V}$, $I_{OUT}=10\text{mA}$)

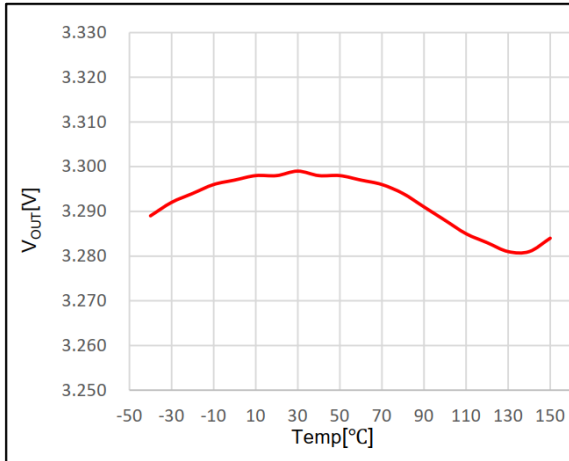

2. I_Q vs V_{IN}

($V_{OUT}=2.8\text{V}$, $I_{OUT}=0\text{mA}$)

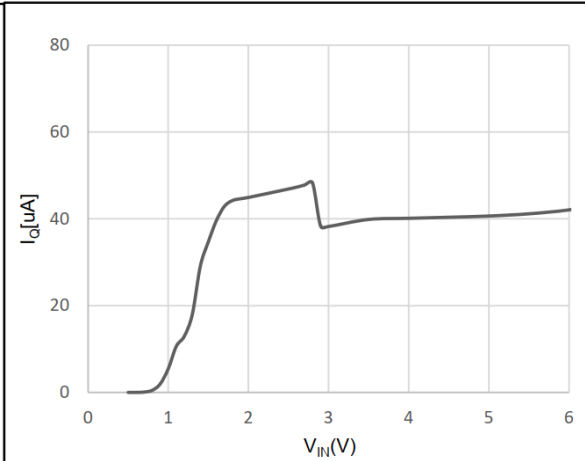

3. V_{OUT} vs I_{OUT}

($V_{IN}=3.8\text{V}$, $V_{OUT}=2.8\text{V}$, $I_{OUT}=0 \rightarrow 300\text{mA}$)

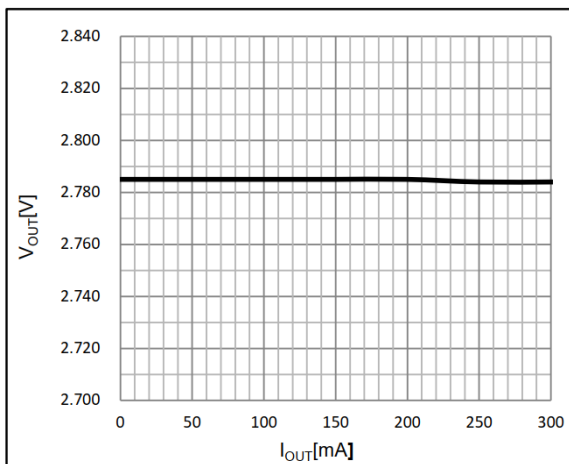

4. V_{OUT} vs V_{IN}

($V_{IN}=3.3\text{V} \rightarrow 6.0\text{V}$, $V_{OUT}=2.8\text{V}$, $I_{OUT}=10\text{mA}$)

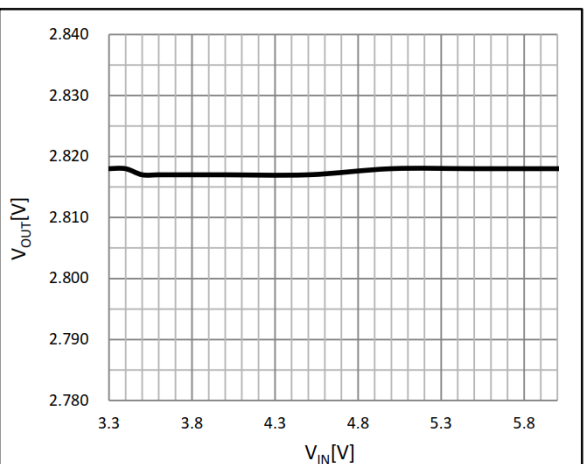

5. Dropout Voltage

($V_{EN}=4.3\text{V}$, $V_{OUT}=95\% \times 3.3\text{V}$, $I_{OUT}=0 \rightarrow 500\text{mA}$)

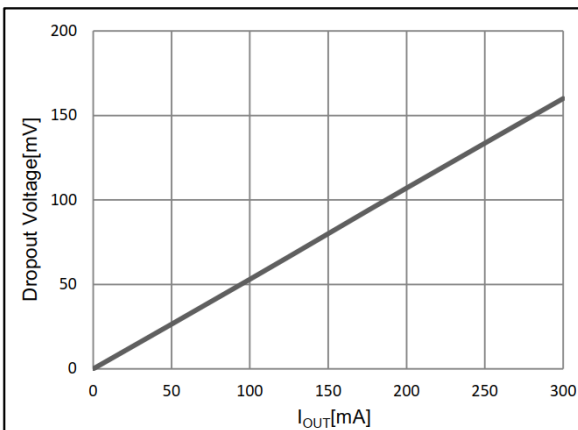

6. V_{EN} Thresholds vs V_{IN}

($V_{OUT}=2.8\text{V}$, $I_{OUT}=0\text{mA}$)

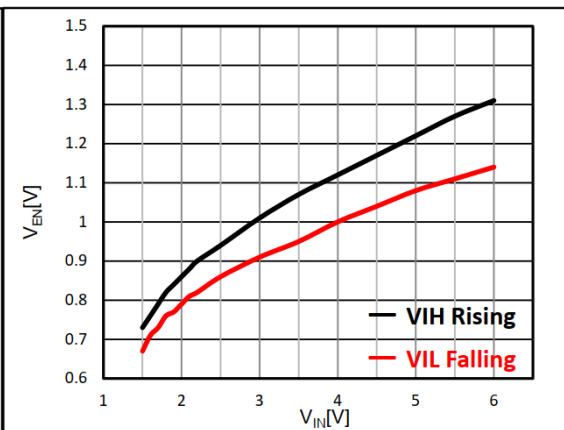

7. Load Transient

($V_{IN}=3.8V$, $V_{OUT}=2.8V$, $I_{OUT}=1\rightarrow 300mA$)

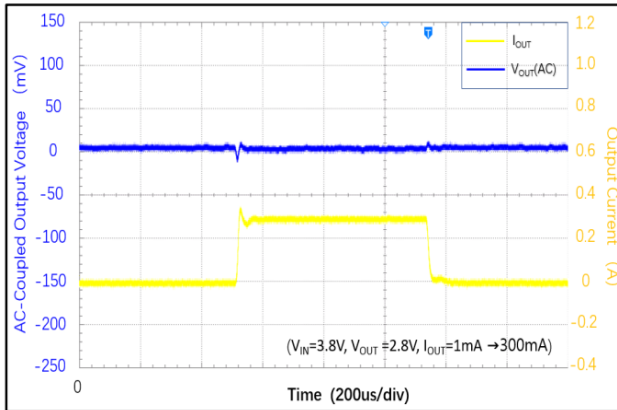

8. Start-Up

($V_{EN}=0\rightarrow 4.3V$, $V_{IN}=3.3V$, $V_{OUT}=2.8V$, load)

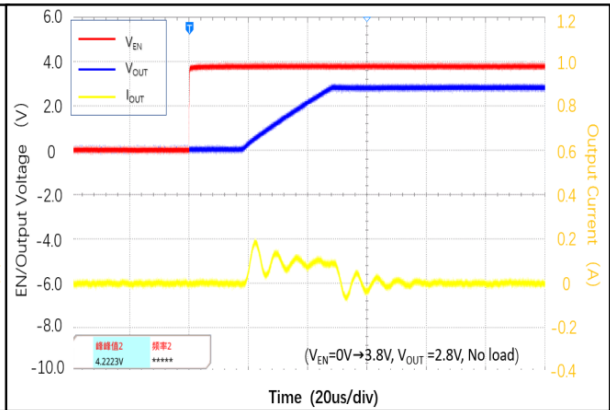

9. Shut-Down

($V_{EN}=3.8V\rightarrow 0V$, $V_{IN}=3.8V$, $V_{OUT}=2.8V$, No load)

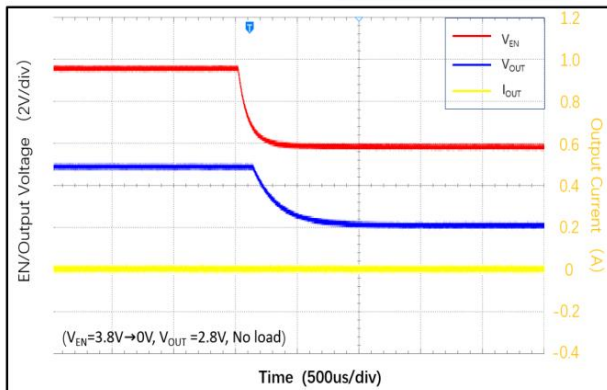

10. Shut-Down

($V_{EN}=4.3V\rightarrow 0V$, $V_{OUT}=3.3V$, $I_{OUT}=500mA$)

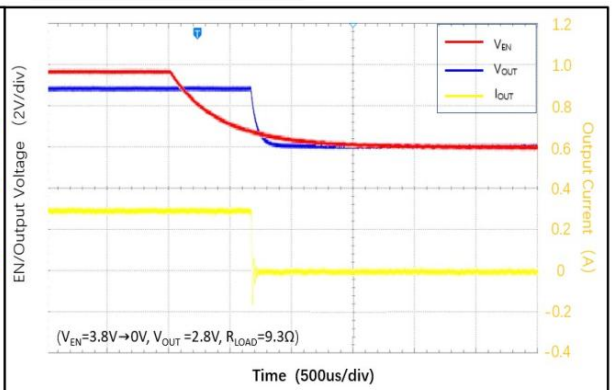

11. PSRR

($V_{IN}=4.3V$, $V_{OUT}=3.3V$, $C_{IN}=none$, $C_{OUT}=1\mu F$)

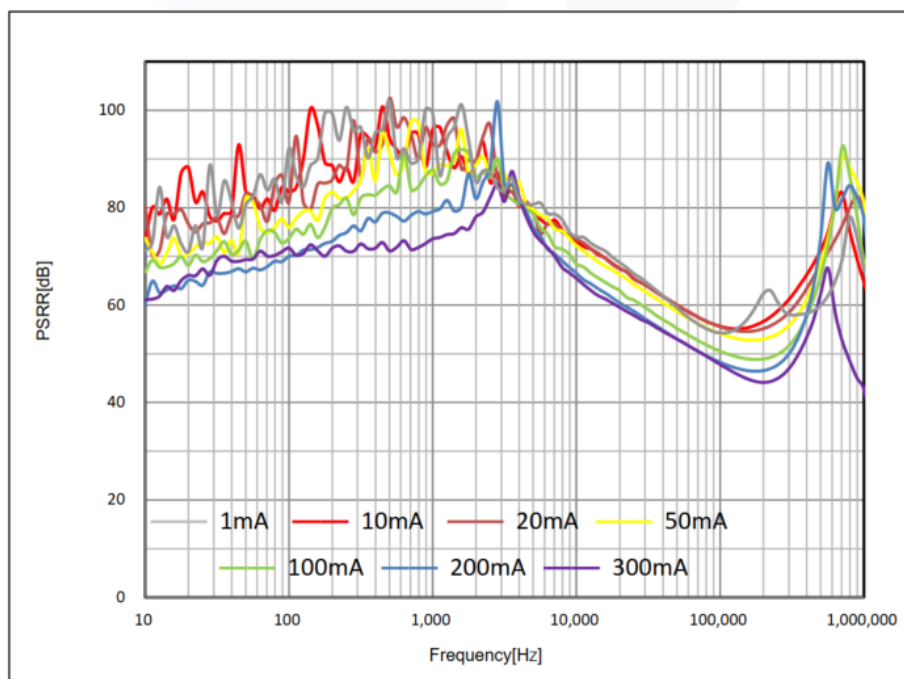

APPLICATION INFORMATION:**● Input Capacitor Selection**

Like any low-dropout regulator, the external capacitors used with the GS2302D Series must be carefully selected for regulator stability and performance. Using a capacitor whose value is $\geq 1\mu\text{F}$ on the GS2302D Series input and the amount of capacitance can be increased without limit. The input capacitor must be located a distance of not more than 0.5 inch from the input pin of the IC and returned to a clean analog ground. Any good quality ceramic or tantalum can be used for this capacitor. The capacitor with larger value and lower ESR (equivalent series resistance) provides better PSRR and line-transient response.

● Output Capacitor Selection

The output capacitor must meet both requirements for minimum amount of capacitance and ESR in all LDOs application. The GS2302D Series is designed specifically to work with low ESR ceramic output capacitor in space-saving and performance consideration. Using a ceramic capacitor whose value is at least $1\mu\text{F}$ on the GS2302D Series output ensures stability. Output capacitor of larger capacitance can reduce noise and improve load transient response, stability, and PSRR. The output capacitor should be located not more than 0.5 inch from the V_{OUT} pin of the GS2302D Series and returned to a clean analog ground.

● Layout considerations

To improve ac performance such as PSRR, output noise, and transient response, it is recommended that the PCB be designed with separate ground planes for V_{IN} and V_{OUT} , with each ground plane connected only at the GND pin of the device.

PACKAGE OUTLINE:

SOT23-5 Package

