

REV. ECN NO.	DESCRIPTION	DATE	DESIGN

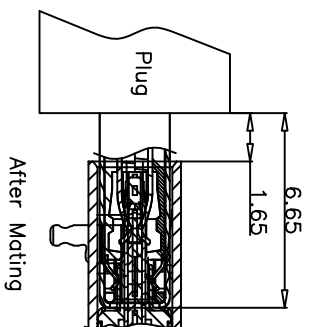
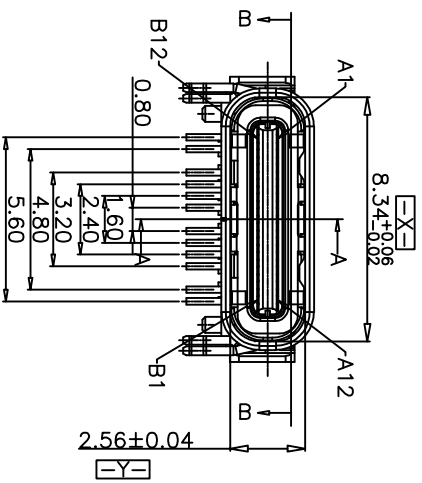
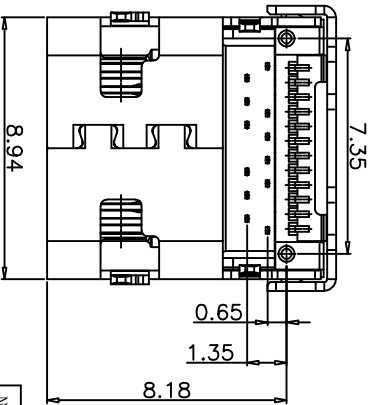
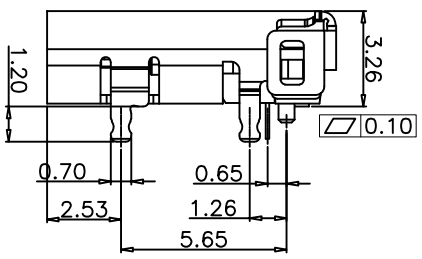
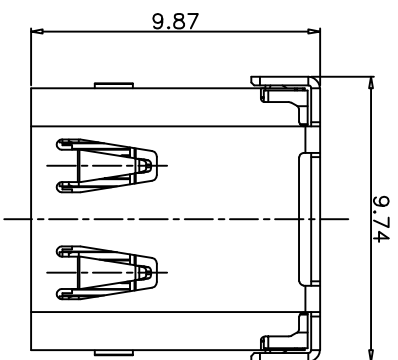
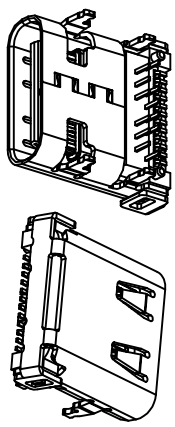
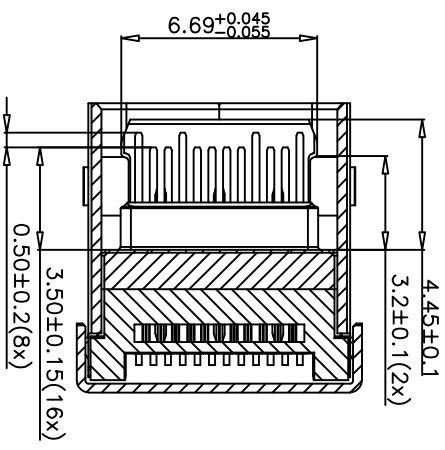
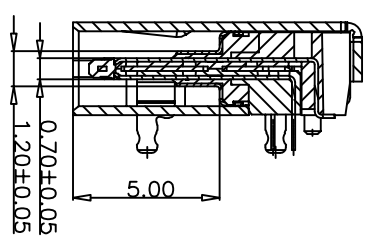
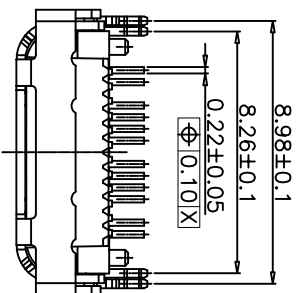

NO.	PART NAME	MATERIAL	FINISH
5	GROUND	SUS 304	CLEAN
4	MID-PLATE	SUS 301	CLEAN
3	OUTER SHELL	SUS 304	Ni:30u Min.
2	CONTACTS	CT025 TM03	Contact area: Ni:50u"; Au 1u"; Solder area: Ni:50u"; Au G/F; Other area: Ni:50u";
1	HOUSING	LCP	BLACK, UL 94V-0

TOLERANCE		NAME(INTENDED USE)	
X.X ±0.30(X)	±10'	CUSTOMER DRAWING	
.XX ±0.20(X)	±8'	PART NO.	TITLE:
XXX ±0.10(X)	±5'	FY23-68TC24F1987-01	
UNITS	mm	DESIGN:	ZXM
MATERILA	---	CHED:	---
FINISH	---	APPD:	---
DRAWG NO.		SCALE	
FY23-68TC24F1987-01		1:1	
SHEET		REV.	
1/2		A	

FUYOU 广东富盈实业精密科技实业有限公司
Shenzhen FUYOU Precision Electronic Technology Co.,LTD.

包装规范说明:

1. 如图所示首先CARRIER TAPE (载带) 需先预留22PCS空格后方可置入成品, 并将COVER TAPE(上带)覆盖于上, 再配合带装机自动卷绕于REEL (塑胶卷轴) 收料。
As shown from picture, the initial starting carrier need to be emptied for 22 pcs, then put connector on Inh carrier; Then cover it with Cover Tape, and Reeling it with Reel auto machine.
2. 在定量包装完成后, 前端CARRIER TAPE亦需预留22PCS空格, 而COVER TAPE配合CARRIER TYPE长度覆盖后, 并须再超出200mm以上, 最后以胶纸贴固, 并于REEL盘上方贴合格标签一张。
In the end of the Reel, need to empty 22 pcs carrier tape; After covering the carrier, then the Cover Tape need to be 200mm longer, and use tape to fix the cover tape to the reel. Put "Qualified label" on the Reel.
3. 注意: COVER TAPE不可浮起或有贴附不顺, 歪斜及成品放置方向错误之现象, 卷盘最外层需缠绕一圈保护带, 再按图示贴3处美纹胶。Attention: no deformation of Cover Tape is allowed (proturded plastic, or not smooth, bednt or product is wrong positioned). The out layer of the reel needs to be wound with a protective tape, and 3 places of masking tape are attached as shown in the figure.
4. 在纸箱内左右, 前后侧各放入一块三角卡板, PE袋中装入10个REEL盘, 并在PE袋中放入2PCS干燥剂, 用胶带封好。在每个纸箱内装入10PCS卷盘, 共1叠, 纸箱内上下各垫一张平卡, 盖上箱盖后以胶带封箱, 于侧位置贴出货标签一张, Inside of carton, at left and right side, put triangle fixed card; Put 10 Reels to PE bag, and put bags of desiccant inside the PE bag. Each carton has 10 reels. Put "Delivery label" on side of the carton.
5. 零箱部分: 出货时须用缓冲物填满。
The fractional box must be filled by cushion before shipment.

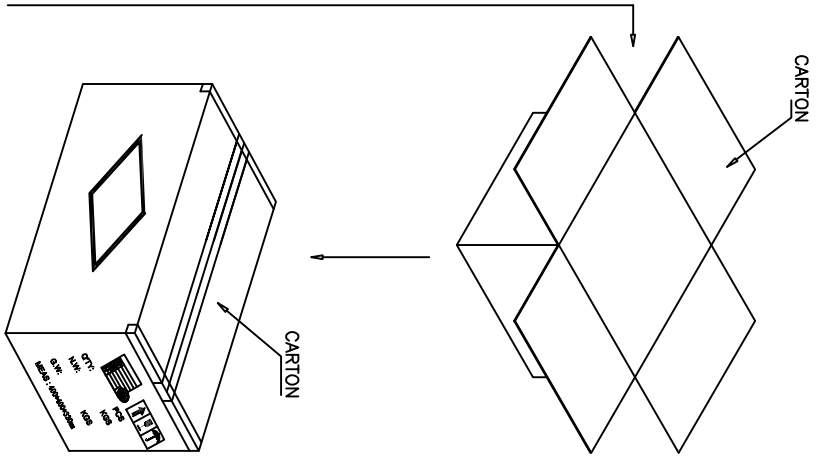
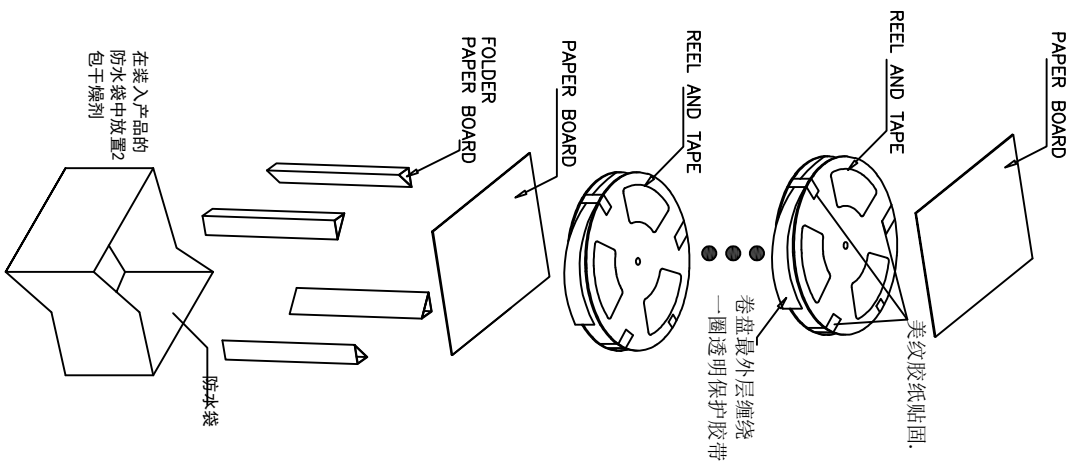
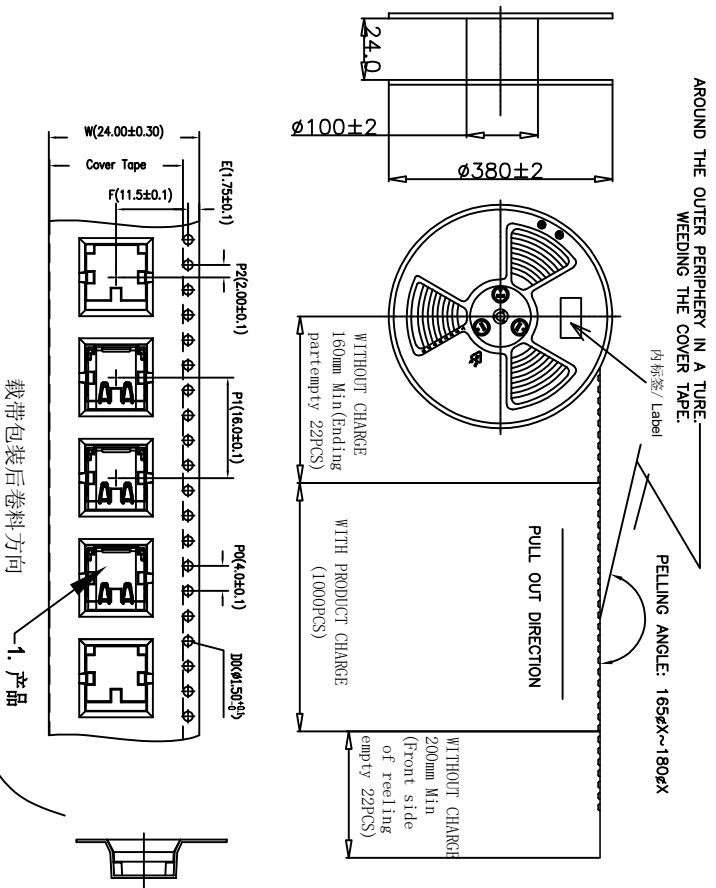

TOLERANCE		NAME (INTENDED USE)		FY23-68TC24F1987-01	
X.X	± 0.30 X.X	$\pm 10^\circ$	PART NO.	FY23-68TC24F1987-01	
XX	± 0.20 .X	$\pm 8^\circ$	CUSTOMER DRAWING	CF 24P板上.87带弹 40G	
.XXX	± 0.10 .XX	$\pm 5^\circ$	DESIGN:	ZXM	
UNITS	mm		CHEG:		
MATERILA	---		APPD:		
FINISH	---				

QTY (包装容量)		WEIGHT (包装重量)	
Pcs/Reel (个/卷)	Reel/Ctos. 卷/箱	Pcs/Ctos. 个/箱	N.W. 净重
1000	10	10000	G.W. 毛重
			*** /kg
			*** /kg

FUYOU 广东富盈实业精密科技实业有限公司
Guangdong FUYOU Precision Electronic Technology Co.,LTD.

SCALE	1:1
SHEET	1/2
REV.	A