

1 Product Identification

GDPZ 2012 M 300 6A0 T F
 ① ② ③ ④ ⑤ ⑥ ⑦

- ① Product Symbol
- ② Dimensions
- ③ Material Code
- ④ Impedance (300: 30Ω)
- ⑤ IR* (6A0: 6.0A)
- ⑥ Packaging Style (B: Bulk; T: Tape & Reel)
- ⑦ Lead Free

2 Appearance, Dimensions

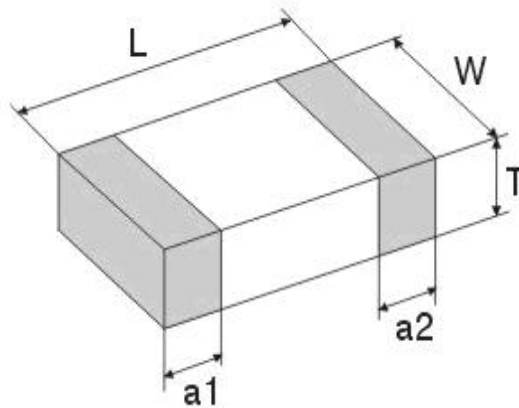

Type	Dimensions (mm) [inch]			
	L	W	T	a1, a2
2012 (0805)	2.0±0.20	1.25±0.20	0.8±0.20	0.40±0.30



3 Rating

Operating Temperature Range : -55 to +125°C

Part No.	Impedance(Ω)	Test Freq. (MHz)	RDC (Ω) max	IR*(mA) max
GDPZ2012M300-6A0TF	30 \pm 25%	100	0.012	6000

4 Curve

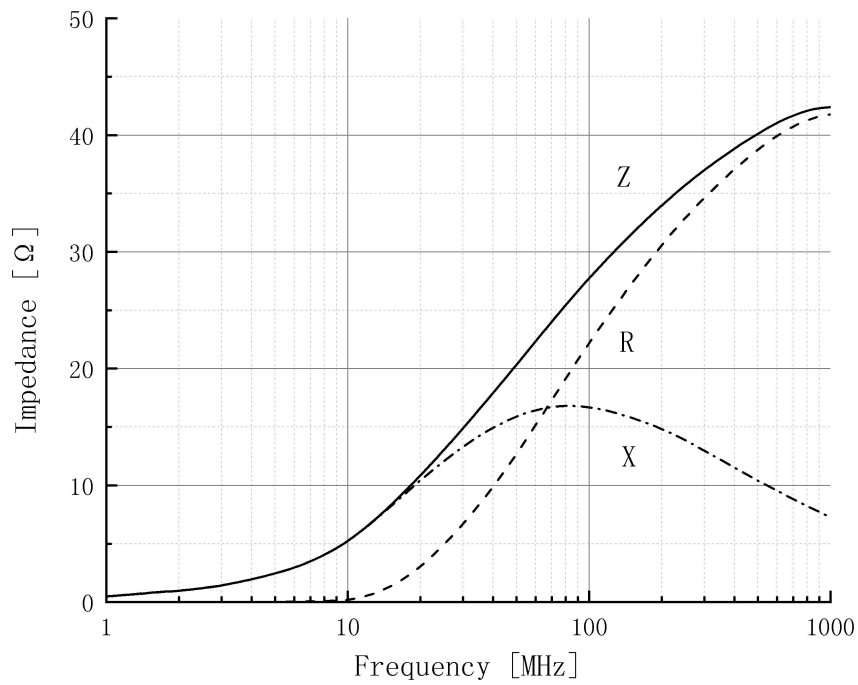

5 Packaging

(1) Dimensions of Reel (mm)

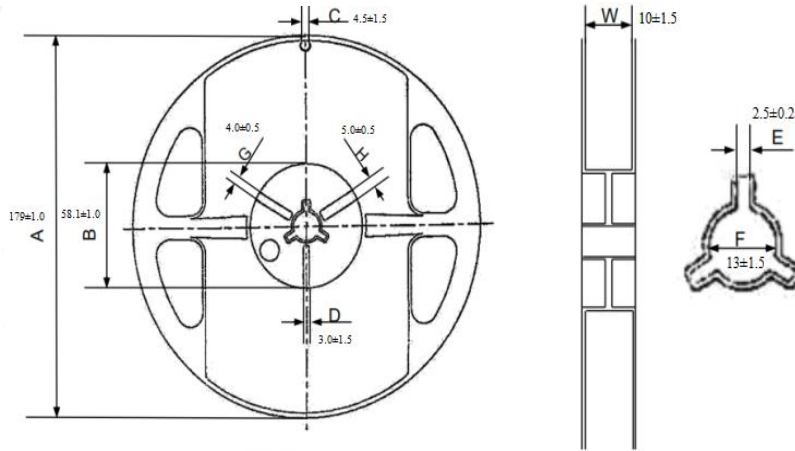

(2) Dimensions of Tape (mm):

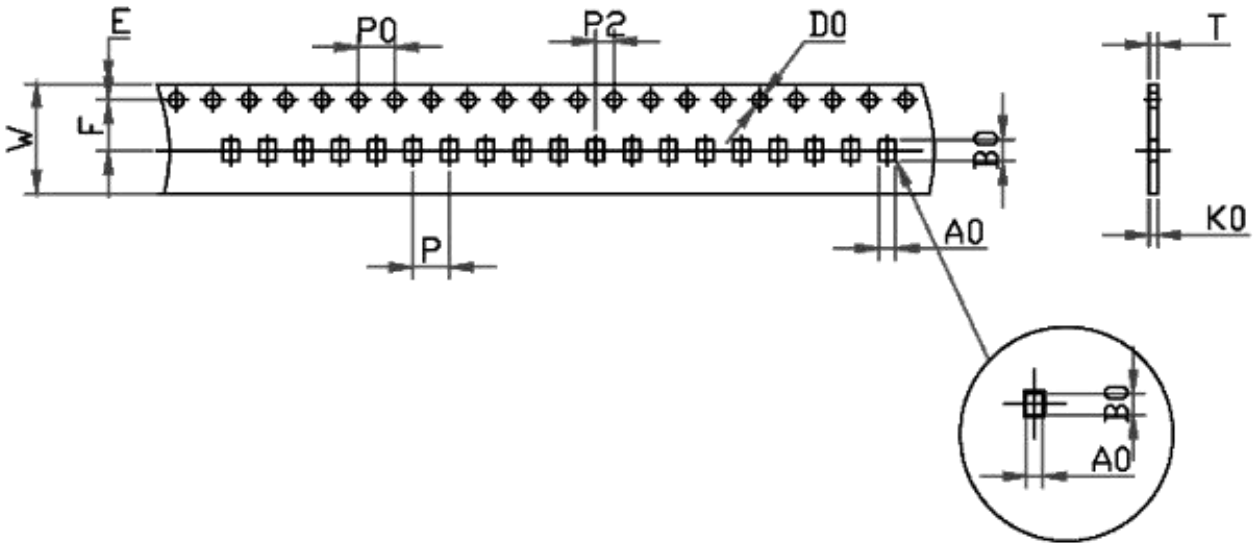

W	A0	B0	K0	P	F	E	D	P0	P2	t	Packaging quantity
8.0 ±0.3	1.5± 0.03	2.3± 0.03	0.95 ±0.1	2.0± 0.05	3.5± 0.1	1.75 ±0.1	1.5+ 0.1/-0.0	4.0 ±0.1	2.0 ±0.1	0.95 ±0.03	4000PCS/REEL