

### • General Description

The AGM218ME combines advanced trench MOSFET technology with a low resistance package to provide extremely low  $R_{DS(ON)}$ . This device is ideal for load switch and battery protection applications.

### • Features

- Advance high cell density Trench technology
- Low  $R_{DS(ON)}$  to minimize conductive loss
- Low Gate Charge for fast switching
- Low Thermal resistance
- 100% Avalanche tested
- 100% DVDS tested

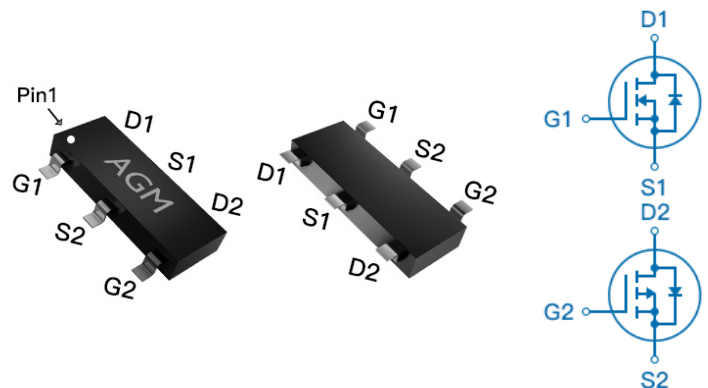
### • Application

- MB/VGA Vcore
- SMPS 2<sup>nd</sup> Synchronous Rectifier
- POL application
- BLDC Motor driver

### Product Summary

BVDSS	RDSON	ID
20V	18mΩ	6A
-20V	28mΩ	-6A

### SOT23-6L Pin Configuration



### Package Marking and Ordering Information

Device Marking	Device	Device Package	Reel Size	Tape width	Quantity
AGM218ME	AGM218ME	SOT23-6L	178mm	8mm	3000

**Table 1. Absolute Maximum Ratings (TA=25°C)**

Symbol	Parameter	Rating		Units
		N-Ch	P-Ch	
$V_{DS}$	Drain-Source Voltage ( $V_{GS}=0V$ )	20	-20	V
$V_{GS}$	Gate-Source Voltage ( $V_{DS}=0V$ )	±12	±12	V
$I_D$	Drain Current-Continuous( $T_C=25^\circ C$ ) (Note 1)	6.0	-6.0	A
	Drain Current-Continuous( $T_C=100^\circ C$ )	4.0	-4.0	A
IDM (pluse)	Drain Current-Continuous@ Current-Pulsed (Note 2)	24	-24	A
$P_D$	Total Power Dissipation( $T_C=25^\circ C$ )	2.0	2.0	W
	Total Power Dissipation( $T_C=100^\circ C$ )	0.8	0.8	W
EAS	Avalanche energy (Note 3)	--	--	mJ
TJ,TSTG	Operating Junction and Storage Temperature Range	-55 To 150	-55 To 150	°C

**Table 2. Thermal Characteristic**

Symbol	Parameter	Typ	Max	Unit
$R_{\theta JA}$	Thermal Resistance Junction-ambient (Steady State) <sup>1</sup>	---	62.5	°C/W

**Table 3. N- Channel Electrical Characteristics (T<sub>J</sub>=25°C unless otherwise noted)**

Symbol	Parameter	Conditions	Min	Typ	Max	Unit
<b>On/Off States</b>						
BVDSS	Drain-Source Breakdown Voltage	VGS=0V ID=250μA	20	--	--	V
IDSS	Zero Gate Voltage Drain Current	VDS=20V,VGS=0V	--	--	1	μA
IGSS	Gate-Body Leakage Current	VGS=±12V,VDS=0V	--	--	±100	nA
VGS(th)	Gate Threshold Voltage	VDS=VGS,ID=250μA	0.4	0.7	1.0	V
gFS	Forward Transconductance	VDS=5V,ID=3A	--	11	--	S
RDS(on)	Drain-Source On-State Resistance	VGS=4.5V, ID=4A	--	18	25	mΩ
		VGS=2.5V, ID=3A	--	21	38	mΩ
<b>Dynamic Characteristics</b>						
Ciss	Input Capacitance	VDS=10V,VGS=0V, F=1MHZ	--	637	--	pF
Coss	Output Capacitance		--	135	--	pF
Crss	Reverse Transfer Capacitance		--	125	--	pF
Rg	Gate resistance	VGS=0V, VDS=0V,f=1.0MHz	--	--	--	Ω
<b>Switching Times</b>						
td(on)	Turn-on Delay Time	VGS=4.5V,VDS=10V, ID=4A, RGEN=6Ω	--	11	--	nS
tr	Turn-on Rise Time		--	30	--	nS
td(off)	Turn-Off Delay Time		--	35	--	nS
tf	Turn-Off Fall Time		--	10	--	nS
Qg	Total Gate Charge	VGS=4.5V, VDS=10V, ID=4A	--	11	--	nC
Qgs	Gate-Source Charge		--	1.2	--	nC
Qgd	Gate-Drain Charge		--	3.5	--	nC
<b>Source-Drain Diode Characteristics</b>						
ISD	Source-Drain Current(Body Diode)		--	--	6.0	A
VSD	Forward on Voltage	VGS=0V,IS=4A	--	--	1.2	V
trr	Reverse Recovery Time	IF=3A , dI/dt=100A/μs ,	--	--	--	ns
Qrr	Reverse Recovery Charge	TJ=25°C	--	--	--	nc

Notes 1.The maximum current rating is package limited.

Notes 2.Repetitive Rating: Pulse width limited by maximum junction temperature

Notes 3.EAS condition: T<sub>J</sub>=25°C

**Table 3. P-Channel Electrical Characteristics (T<sub>J</sub>=25°C unless otherwise noted)**

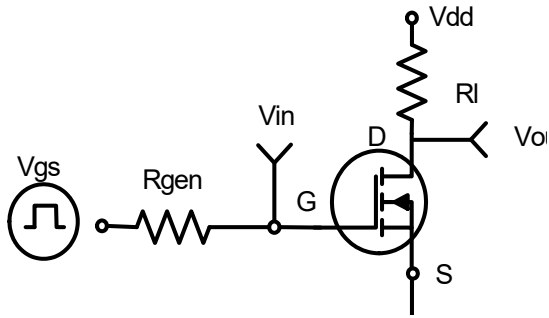
Symbol	Parameter	Conditions	Min	Typ	Max	Unit
<b>On/Off States</b>						
BVDSS	Drain-Source Breakdown Voltage	VGS=0V ID=-250μA	-20	--	--	V
IDSS	Zero Gate Voltage Drain Current	VDS=-20V, VGS=0V	--	--	-1	μA
IGSS	Gate-Body Leakage Current	VGS=±12V, VDS=0V	--	--	±100	nA
VGS(th)	Gate Threshold Voltage	VDS=VGS, ID=-250μA	-0.4	-0.7	-1.0	V
gFS	Forward Transconductance	VDS=-5V, ID=-3A	--	7	--	S
RDS(on)	Drain-Source On-State Resistance	VGS=-4.5V, ID=-4A	--	28	38	mΩ
		VGS=-2.5V, ID=-3A	--	37	50	mΩ
<b>Dynamic Characteristics</b>						
Ciss	Input Capacitance	VDS=-10V, VGS=0V, F=1MHZ	--	673	--	pF
Coss	Output Capacitance		--	115	--	pF
Crss	Reverse Transfer Capacitance		--	109	--	pF
Rg	Gate resistance	VGS=0V, VDS=0V, f=1.0MHz	--	--	--	Ω
<b>Switching Times</b>						
td(on)	Turn-on Delay Time	VGS=-10V, VDS=-10V, ID=-5A, RGEN=3Ω	--	15	--	nS
tr	Turn-on Rise Time		--	35	--	nS
td(off)	Turn-Off Delay Time		--	30	--	nS
tf	Turn-Off Fall Time		--	14	--	nS
Qg	Total Gate Charge	VGS=-10V, VDS=-10V, ID=-5A	--	18	--	nC
Qgs	Gate-Source Charge		--	1.3	--	nC
Qgd	Gate-Drain Charge		--	2.5	--	nC
<b>Source-Drain Diode Characteristics</b>						
ISD	Source-Drain Current(Body Diode)		--	--	-6.0	A
VSD	Forward on Voltage	VGS=0V, IS=-4A	--	--	-1.2	V
trr	Reverse Recovery Time	IF=-4A , di/dt=100A/μs , TJ=25°C	--	--	--	ns
Qrr	Reverse Recovery Charge		--	--	--	nc

Notes 1.The maximum current rating is package limited.

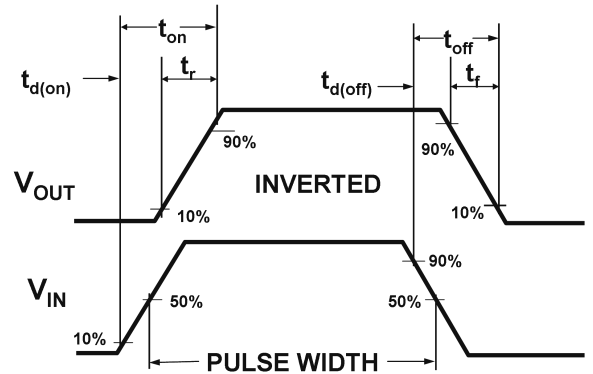
Notes 2.Repetitive Rating: Pulsewidth limited by maximum junction temperature Notes

3.EAS condition: T<sub>J</sub>=25°C

**N-Channel Typical Electrical and Thermal Characteristics**

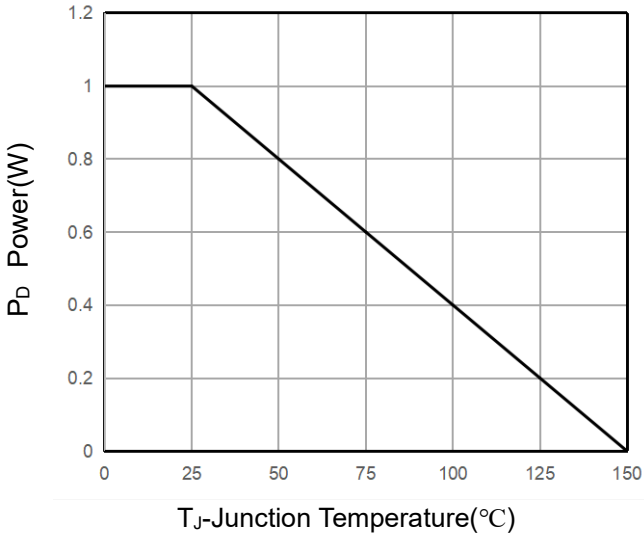


**Figure 1: Switching Test Circuit**



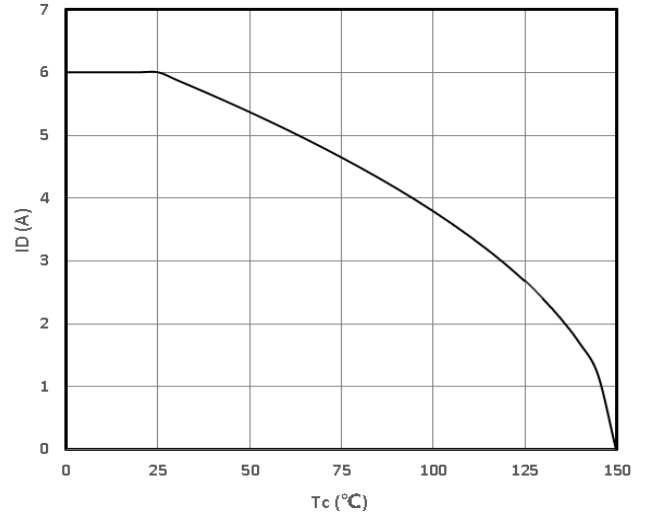
**Figure 2: Switching Waveforms**

**Power Dissipation**

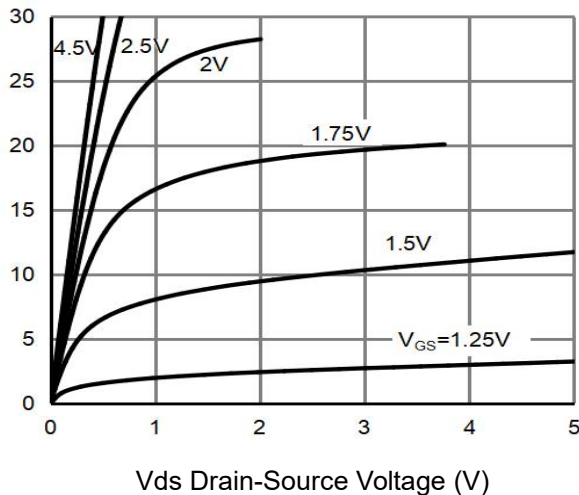


**Figure 3 Power Dissipation**

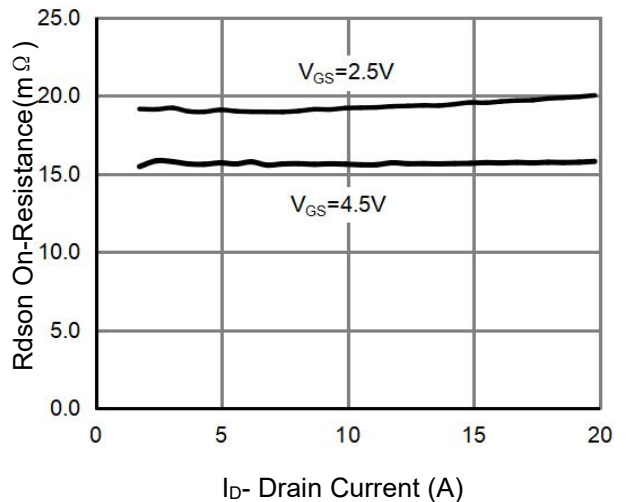
**Maximum Drain Current**



**Figure 4 Drain Current**



**Figure 5 Output Characteristics**



**Figure 6 Drain-Source On-Resistance**

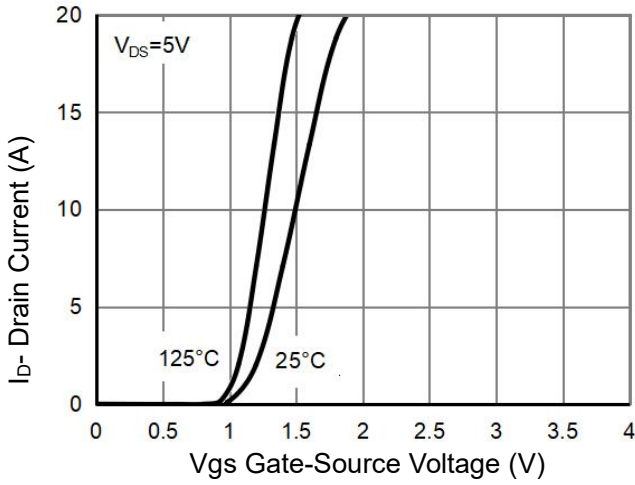


Figure 7 Transfer Characteristics

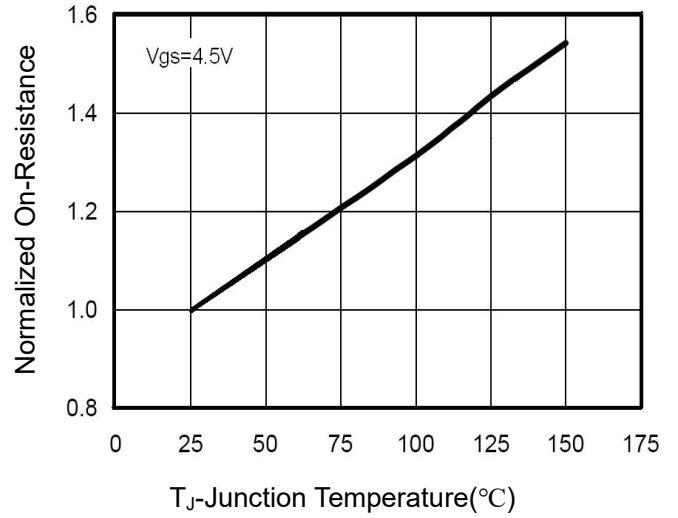


Figure 8 Drain-Source On-Resistance

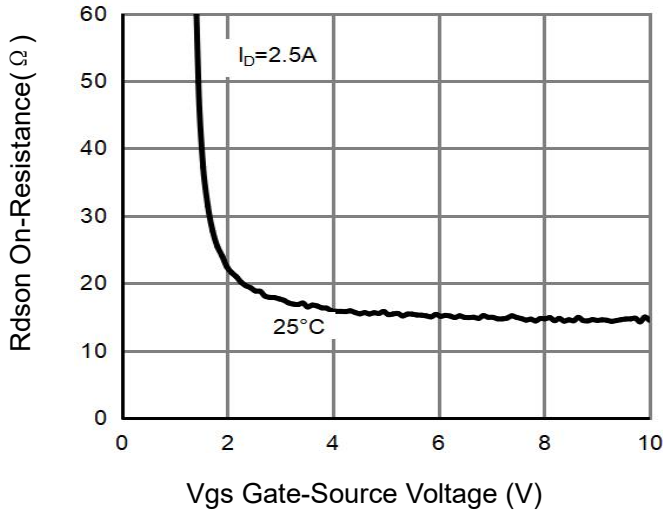


Figure 9 Rdson vs. Vgs

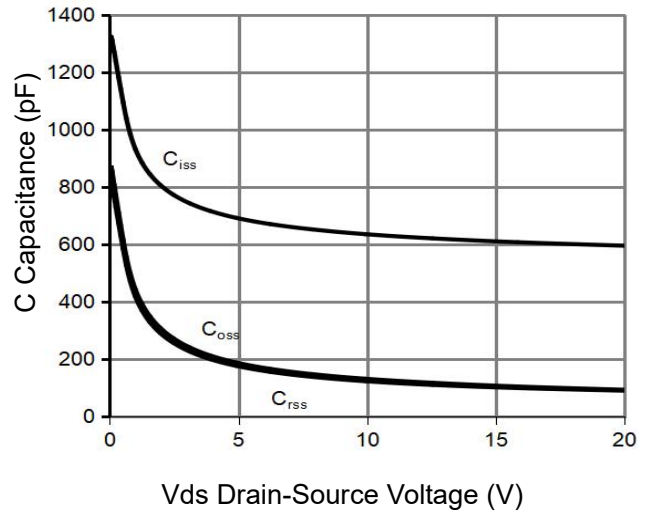


Figure 10 Capacitance vs Vds

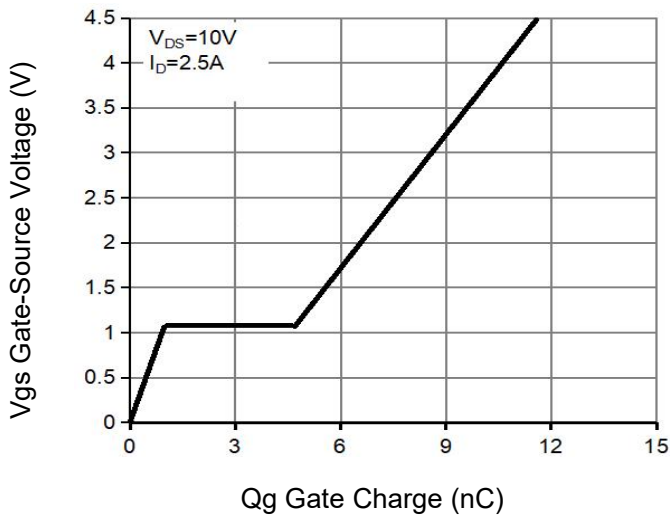


Figure 11 Gate Charge

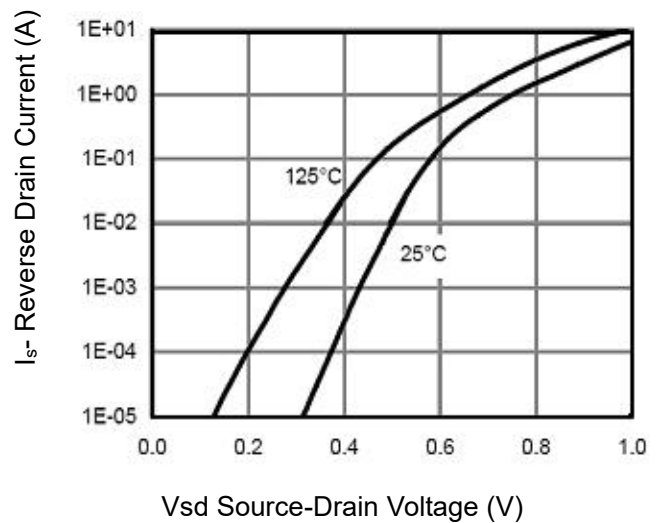


Figure 12 Source- Drain Diode Forward

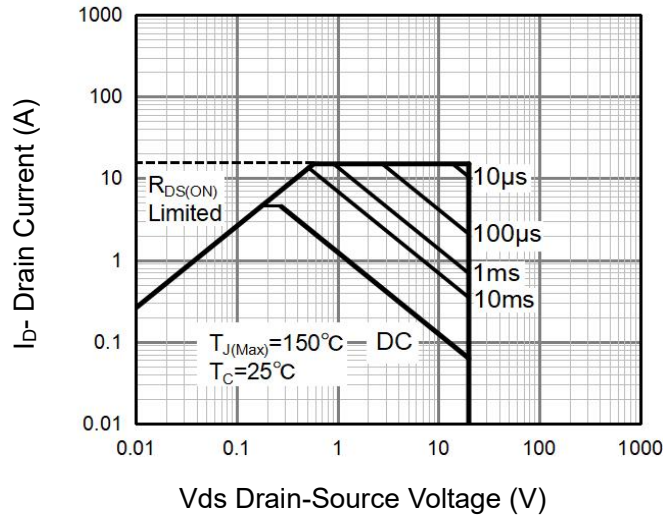


Figure 13 Safe Operation Area

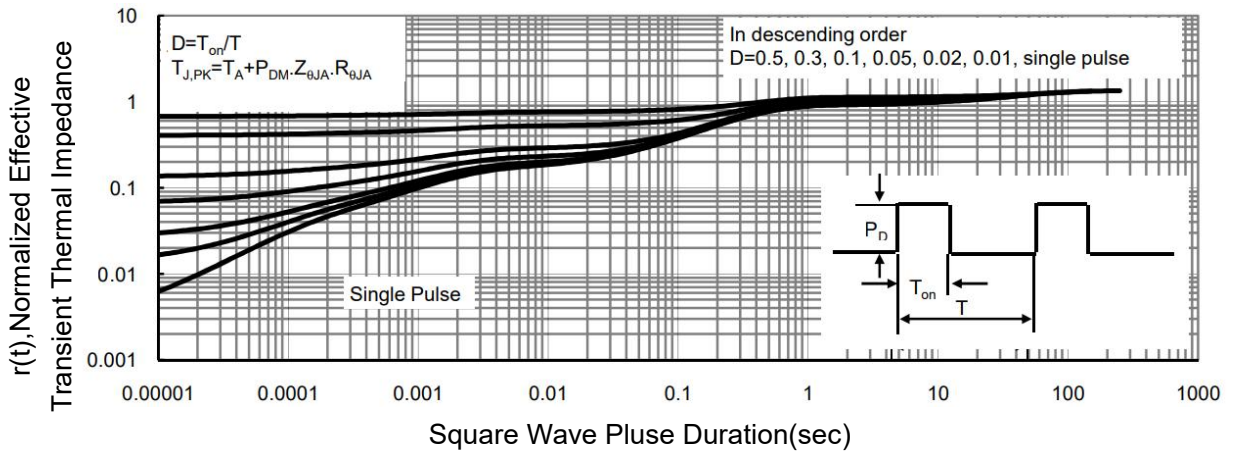
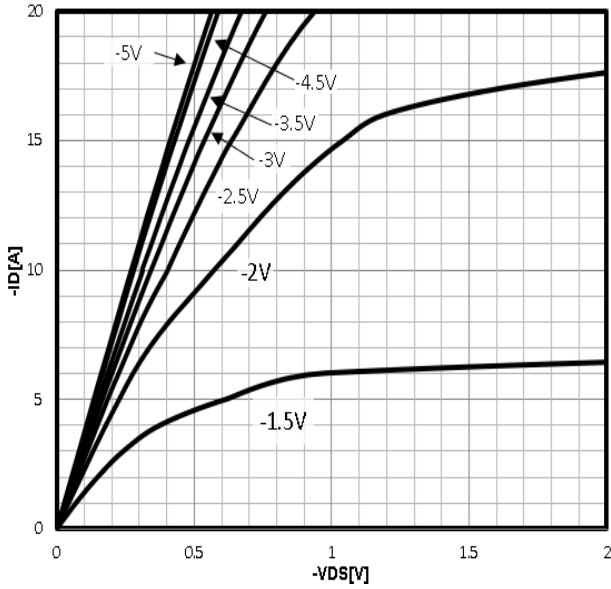


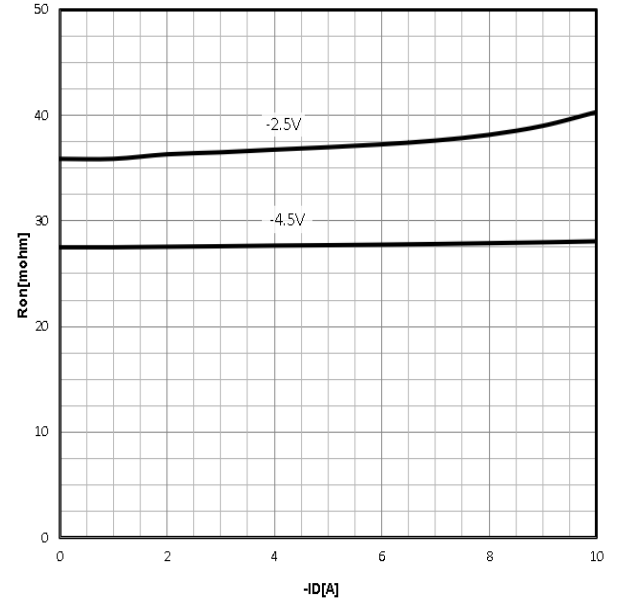
Figure 14 Normalized Maximum Transient Thermal Impedance

### P-Channel Characteristics Curve:

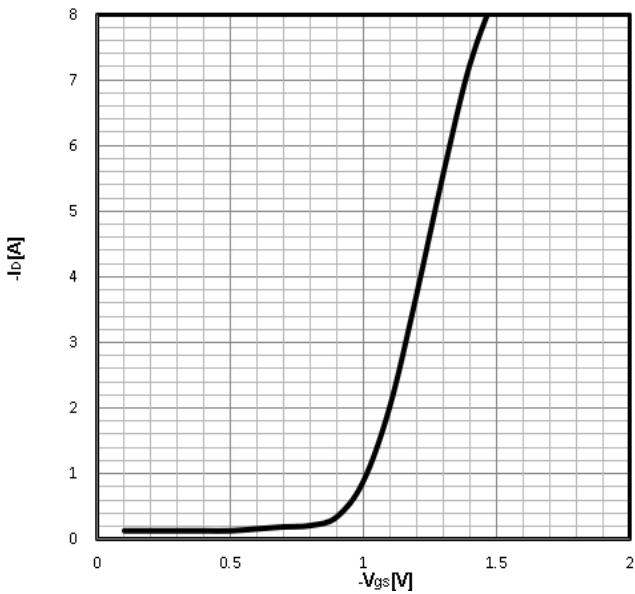
**Typ. output characteristics**  
 $I_D = f(V_{DS})$



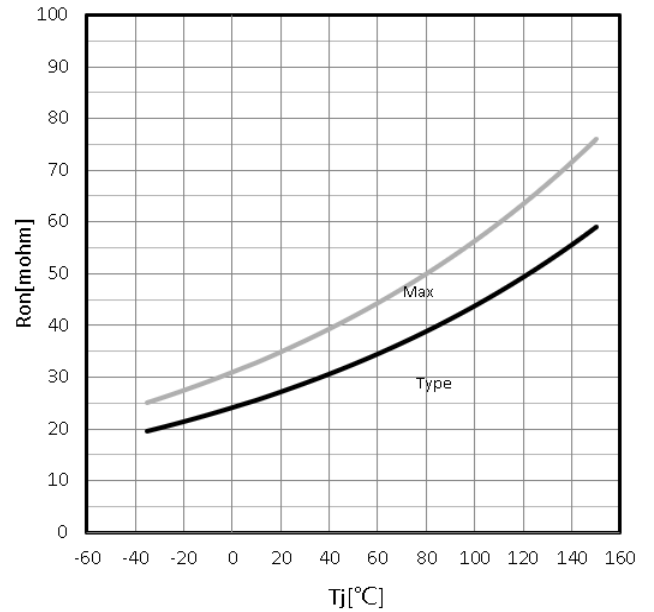
**Typ. drain-source on resistance**  
 $R_{DS(on)} = f(I_D)$



**Typ. transfer characteristics**  
 $I_D = f(V_{GS})$

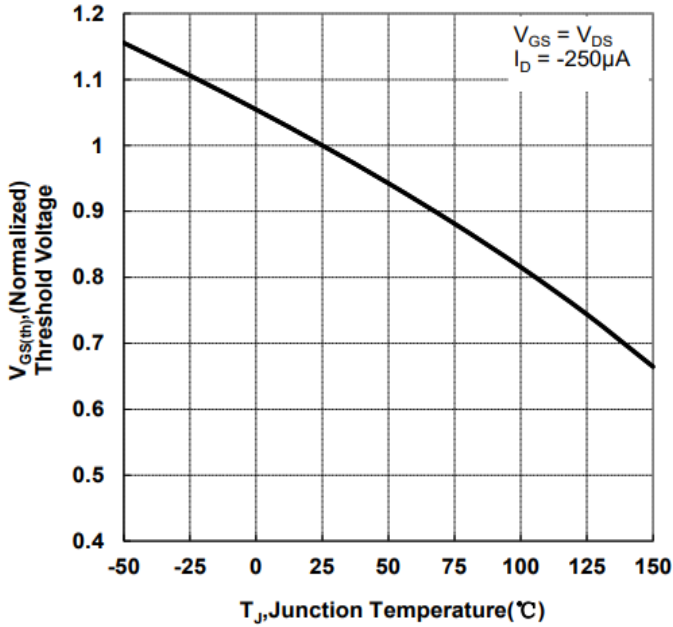


**Drain-source on-state resistance**  
 $R_{DS(on)} = f(T_j); I_D = -4A; V_{GS} = -4.5V$

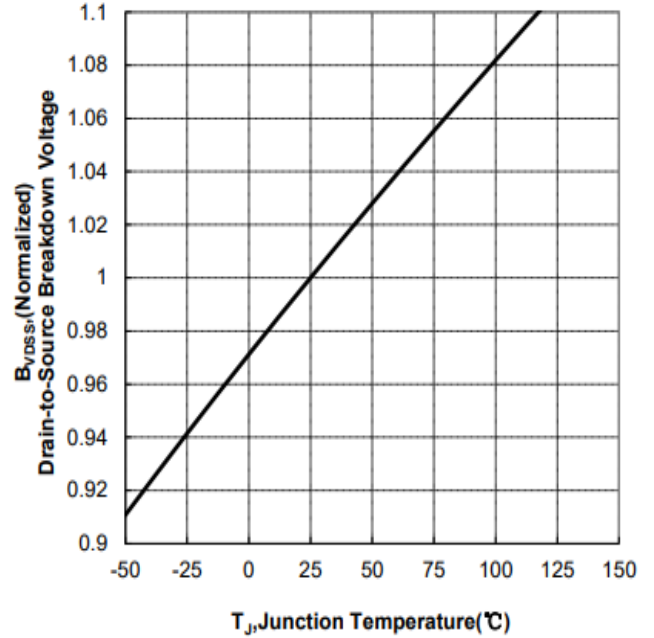


**Gate Threshold Voltage**

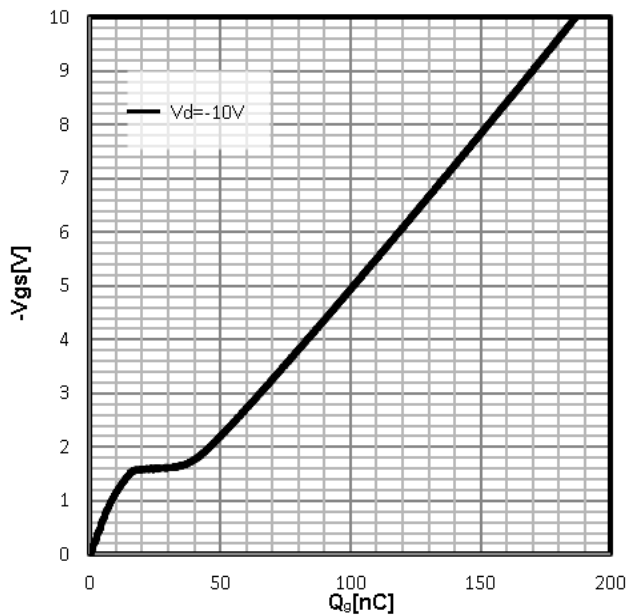
$$-V_{TH}=f(T_j); I_D=-250\mu A$$


**Drain-source breakdown voltage**

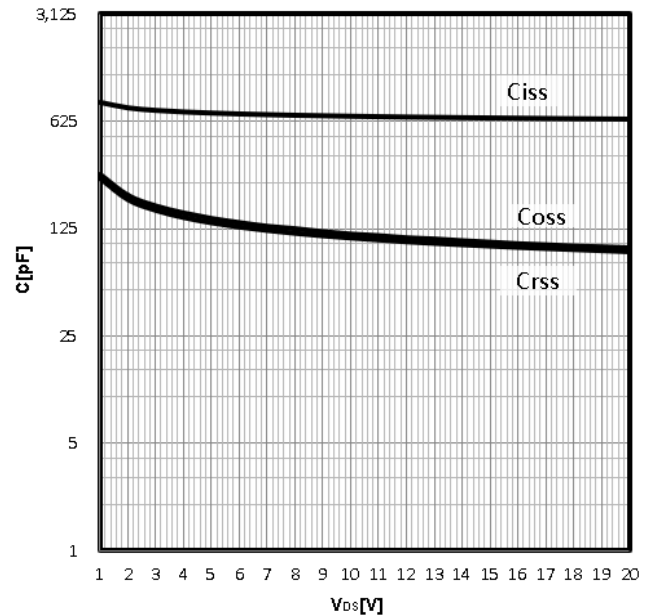
$$V_{BR(DSS)}=f(T_j); I_D=-250\mu A$$


**Typ. gate charge**

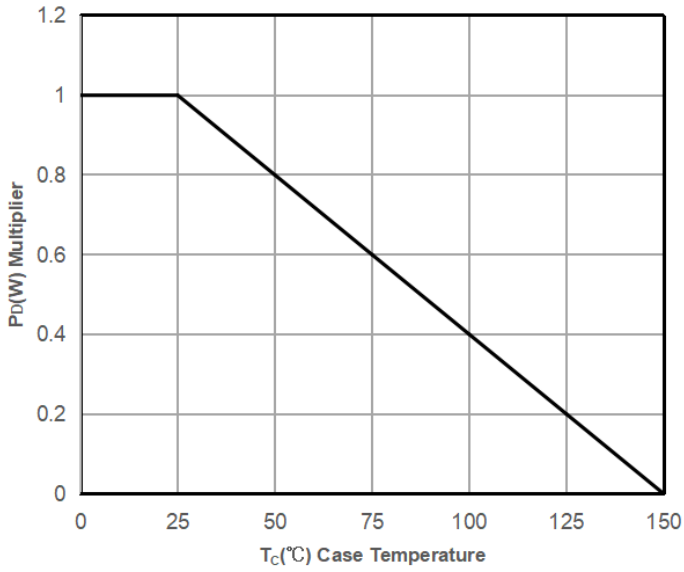
$$V_{GS}=f(Q_{gate}); I_D=-5A$$


**Typ. capacitances**

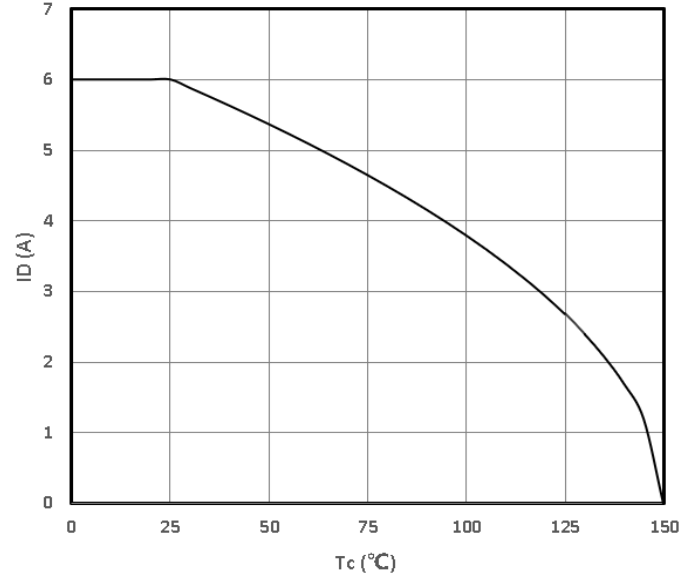
$$C=f(V_{DS}); V_{GS}=0V; f=1MHz$$



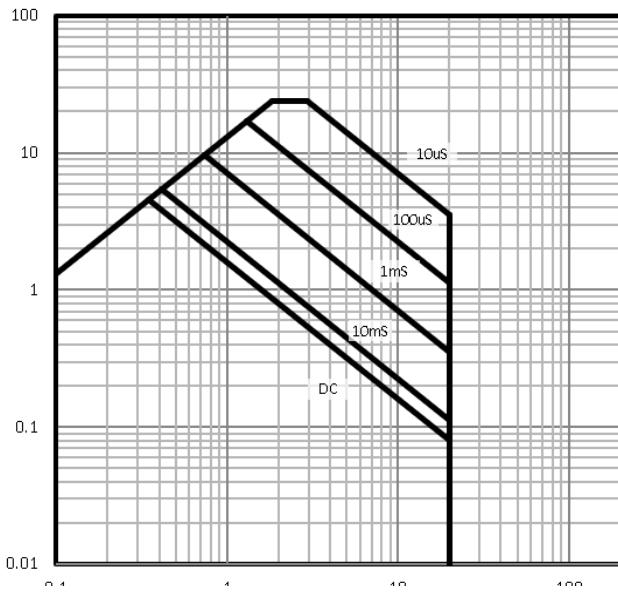
**Power Dissipation**  
 $P_{tot}=f(T_C)$



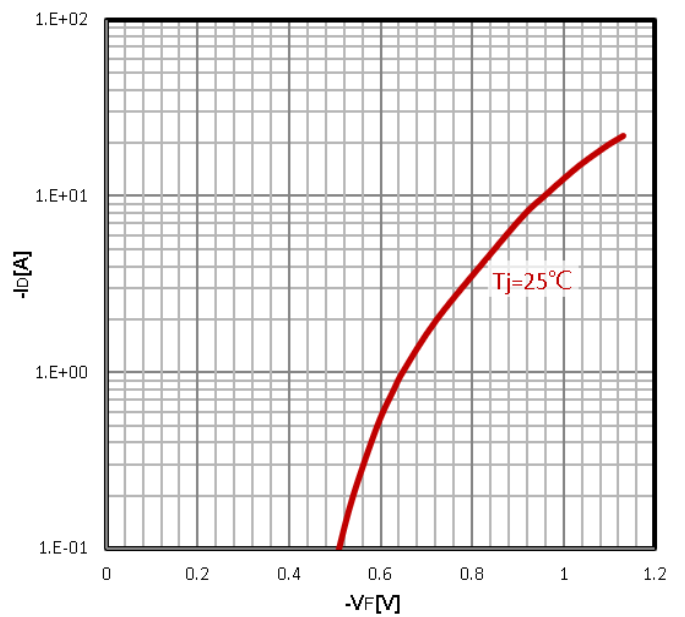
**Maximum Drain Current**  
 $-I_D=f(T_C)$



**Safe operating area**  
 $-I_D=f(-V_{DS})$

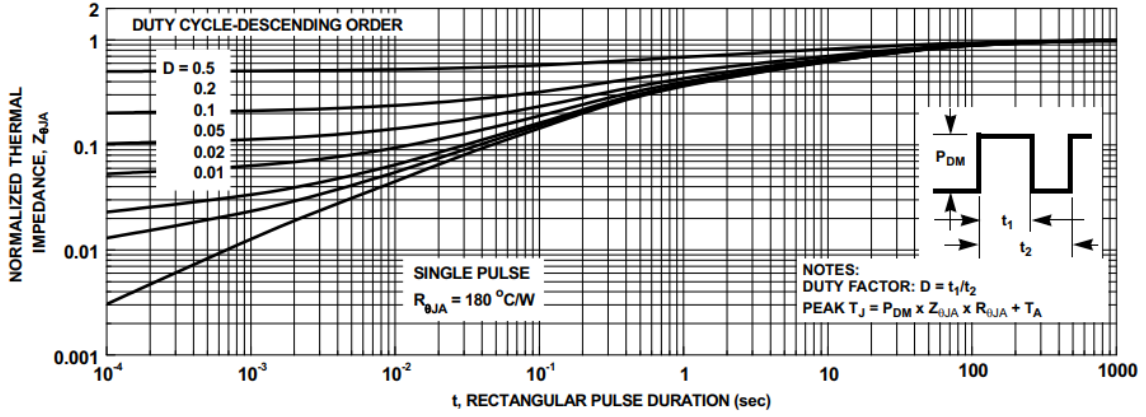


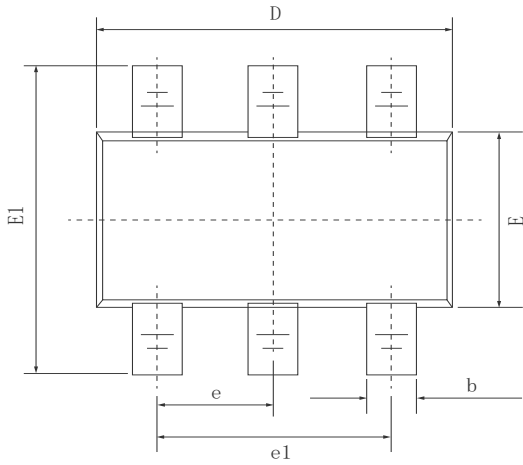
**Body Diode Forward Voltage Variation**  
 $-I_F=f(-V_{DS})$



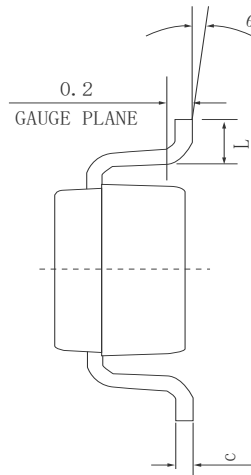
Max. transient thermal impedance

$$Z_{thJC} = f(t_p)$$



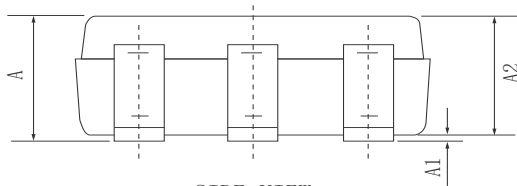
**●Dimensions (SOT23-6L)**


TOP VIEW

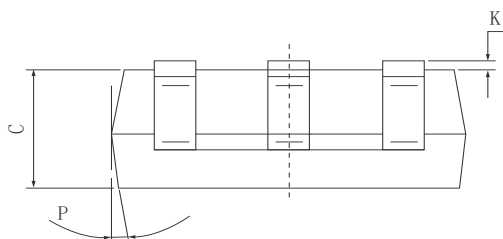
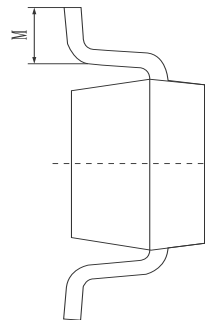
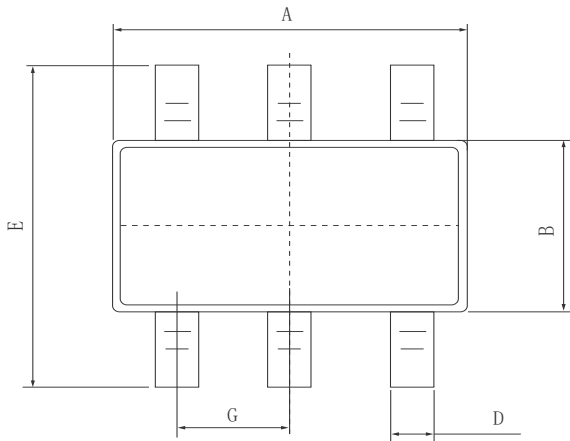


SIDE VIEW

SYMBOL	MIN	NOM	MAX
A	—	—	1.20
A1	0.00	0.05	0.10
A2	1.00	1.10	1.20
b	0.30	0.40	0.50
c	0.10	0.125	0.15
e1	1.80	1.90	2.00
D	2.80	2.90	3.00
E	1.50	1.60	1.70
E1	2.60	2.80	3.00
L	0.30	0.45	0.60
$\theta$	0°	4°	8°
e	0.95BSC		



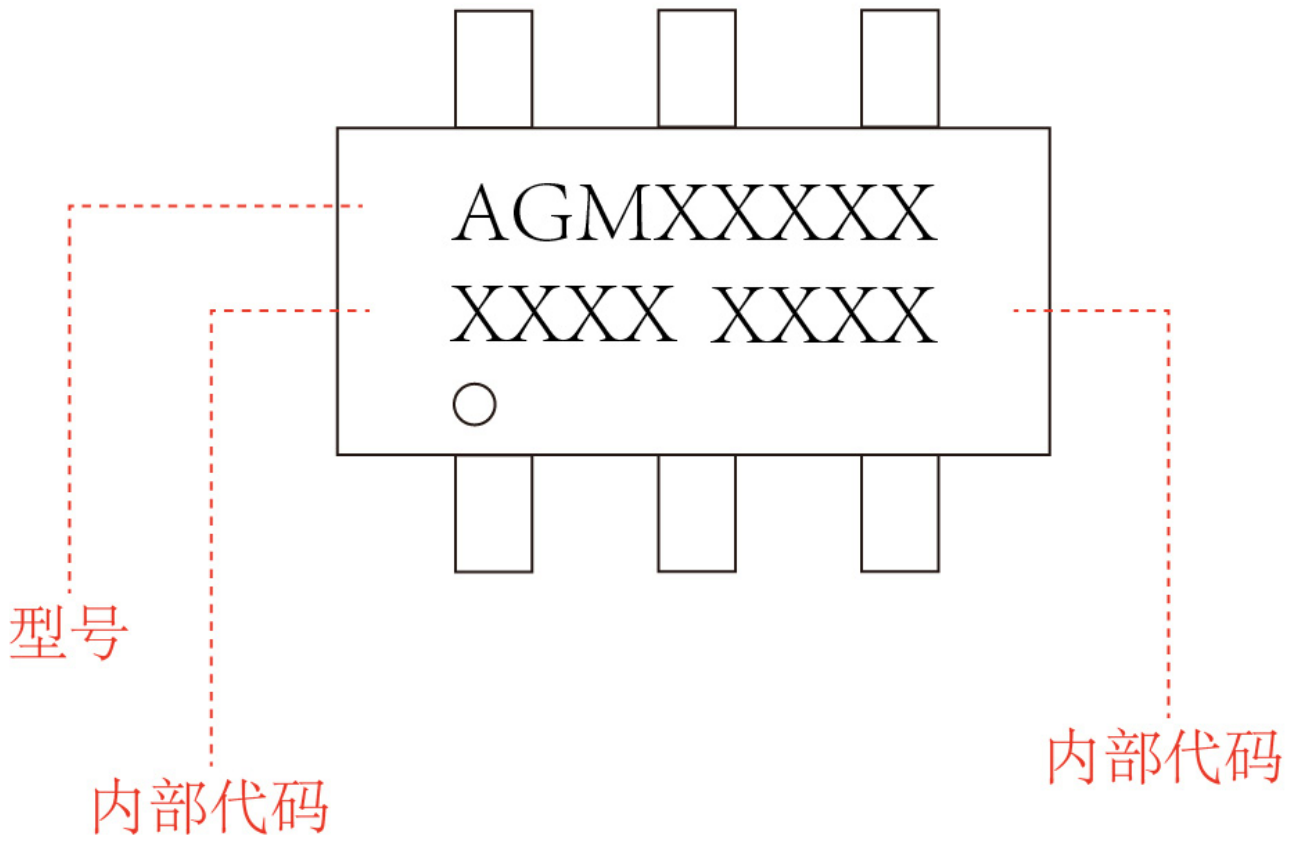
SIDE VIEW



DIM	MILLIMETERS
A	2.82~3.02
B	1.60±0.10
C	1.10±0.05
D	0.40±0.10
E	2.65~2.95
G	0.95typ
K	0.00~0.10
M	0.20MIN
P	9±2°

SOT23-6L

Marking Instructions:




Disclaimer:

The information provided in this document is believed to be accurate and reliable. However, Shenzhen Core Control Source Electronics Technology Co., Ltd. does not assume any responsibility for the following consequences. Do not consider the use of such information or use beyond its scope.

The information mentioned in this document may be changed at any time without notice.

The products and information provided in this document do not infringe patents. Shenzhen Core Control Source Electronics Technology Co., Ltd. assumes no responsibility for any infringement of any other rights of third parties. The result of using such products and information.

This document is the second version issued on March 20th, 2024. This document replaces all previously provided information.

 It is a registered trademark of Shenzhen Core Control Source Electronics Technology Co., Ltd.

Copyright © 2017 Shenzhen Core Control Source Electronics Technology Co., Ltd. all rights reserved.