

Description

The **MD-DRA371-H10** is a high SNR, high AOP and multi Mode bottom port digital MEMS microphone with 1-bit PDM output, consists of a MEMS sensor and a low noise level amplifier, and a Σ - Δ modulator.

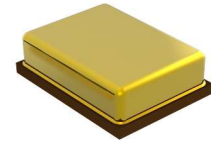

Top View

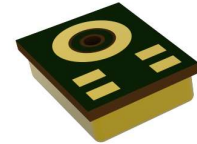

Bottom View

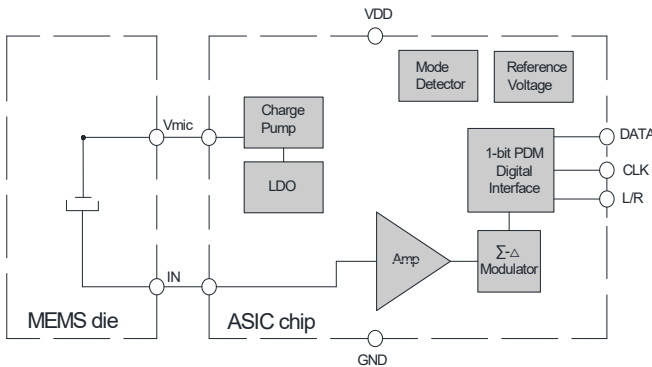

Fig. 1 Microphone block diagram

Key Features

- ◇ 4.0x3.0x1.2mm Bottom Port
- ◇ 1-bit PDM Output
- ◇ Narrow Sensitivity +/-1dB
- ◇ High SNR of 70dBA
- ◇ High AOP of 128dBSPL
- ◇ Flat Frequency Performance
- ◇ Multi Mode(Sleep,Low power,Normal)
- ◇ Compatible with Standard SMD Reflow Technology
- ◇ RoHS Compliance & Halogen Free

Typical Applications

- ◇ Mobilephones
- ◇ Wireless Headsets
- ◇ Smart Speakers
- ◇ Wearable Electronics
- ◇ Portable Electronics
- ◇ Smart Home Electronics

Maximum Ratings

Stresses at the maximum ratings shown in Table 1 may cause permanent damage to the device. These are stress ratings only at which the device may not function when an operation at these or any other condition beyond those specified under “Electro-Acoustic Specifications”.

Table 1 Maximum Ratings

Parameter	Maximum Ratings	Unit
Supply voltage	3.6	V
Voltage on any pin	3.6	V
Operation temperature range	-40~85	°C
Storage temperature range	-40~100	°C

Electro-Acoustic Specifications

Table 2 Normal Mode Electrical Specifications

Test condition: +25±2°C, 60%~70% RH, 86~106Kpa, F_{CLK}=2.4MHz, V_{DD}=1.8V, no load, unless otherwise noted.

Symbol	Description	Min	Typ.	Max	Units
F _{CLK}	Clock Frequency	1.2	2.4	3.3	MHz
I _{DD}	Supply Current ¹		1000	1100	uA
S	Sensitivity ³ ,94dB SPL@1KHz	-38	-37	-36	dBFS ²
SNR	20-8KHz Bandwidth, A-weighted		70		dB(A)
THD	94dB SPL@1KHz		0.10	0.5	%
	123dB SPL@1KHz		1		%
AOP	10%THD@1KHz		128		dB SPL
PSR	Measured with 217Hz,100mVpp square wave		-97	-90	dBFS

Table 3 Low Power Mode Electrical Specifications

Test condition: +25±2°C, 60%~70% RH, 86~106Kpa, F_{CLK}=768KHz, V_{DD}=1.8V, no load, unless otherwise noted.

Symbol	Description	Min.	Typ.	Max.	Units
F _{CLK}	Clock Frequency	450	768	850	KHz
I _{DD}	Supply Current		280	350	uA
S	Sensitivity,94dB SPL@1KHz	-22	-21	-20	dBFS
SNR	20-8KHz Bandwidth, A-weighted		68		dB(A)
THD	94dB SPL@1KHz		0.10	0.5	%
	114dB SPL@1KHz		1		%
AOP	10%THD@1KHz		117		dB SPL
PSR	Measured with 217Hz,100mVpp square wave		-86	-70	dBFS

Note 1: The current consumption depends on the applied clock frequency and the load on the DATA output

Note 2: dBFS=20*logA/B, where A is the level of signal, and B is the level that corresponds to full-scale level

Note 3: Relative to the rms level of a sine wave with positive amplitude equal to 100% 1s density and
Negative amplitude equal to 0% 1s density

Note 4: Frequency response, sensitivity and current consumption are tested by 100% on product line.

Table 4 Electrical Specifications

Test condition: +25±2°C, 60%~70% RH, 86~106Kpa, no load, unless otherwise noted.

Symbol	Description	Min.	Typ.	Max.	Units	
V _{DD}	Supply Voltage	1.6	1.8	3.3	V	
F _{CLK}	Clock Frequency	Standby Mode		320	KHz	
		Low Power Mode	450	768	850	KHz
		Normal Mode	1.2	2.4	3.3	MHz
Data Format		1/2 Cycle PDM				
Directivity		Omni-directional				
Polarity	Increasing sound pressure	Increasing density of 1's				
I _{sc}	Shortcircuit current, Grounded DATA	1		20	mA	
C _{LOAD}	Load capacitance			200	pF	
Reset time	Time to start up in any mode after V _{DD} has been off for more than 10ms, while CLOCK remained on			20	ms	
Start-up time	Start-up into normal mode or LP mode			20	ms	
Mode-switch time	Mode-switch Normal mode to LP mode or LP mode to Normal mode		20		ms	

Table 5 Digital input—output specifications

Parameter	Symbol	Min.	Typ.	Max.	Unit	Note
Clock duty cycle		45		55	%	
Operation Voltage	V _{DD}	1.6		3.3	V	
Input Logic Low Level	V _{IL}	-0.3		0.28×V _{DD}	V	
Input Logic High Level	V _{IH}	0.65×V _{DD}		V _{DD} +0.3	V	
Hysteresis width	V _{hys}	0.08			V	
Output Logic Low Level	V _{OL}			0.3×V _{DD}	V	
Output Logic High Level	V _{OH}	0.7×V _{DD}			V	
Clock rise time	t _{CR}			13	ns	
Clock fall time	t _{CF}			13	ns	
Delay time for DATA driven	t _{DD}	28			ns	
Delay time for data valid	t _{DV}			100	ns	
Delay time for data high Z	t _{HZ}	14		26	ns	

Table 6 L/R Channel Configuration

Channel	L/R pad connection	DATA driven	Data high Z
DATA1	GND	CLK falling edge	CLK rising edge
DATA2	VDD	CLK rising edge	CLK falling edge

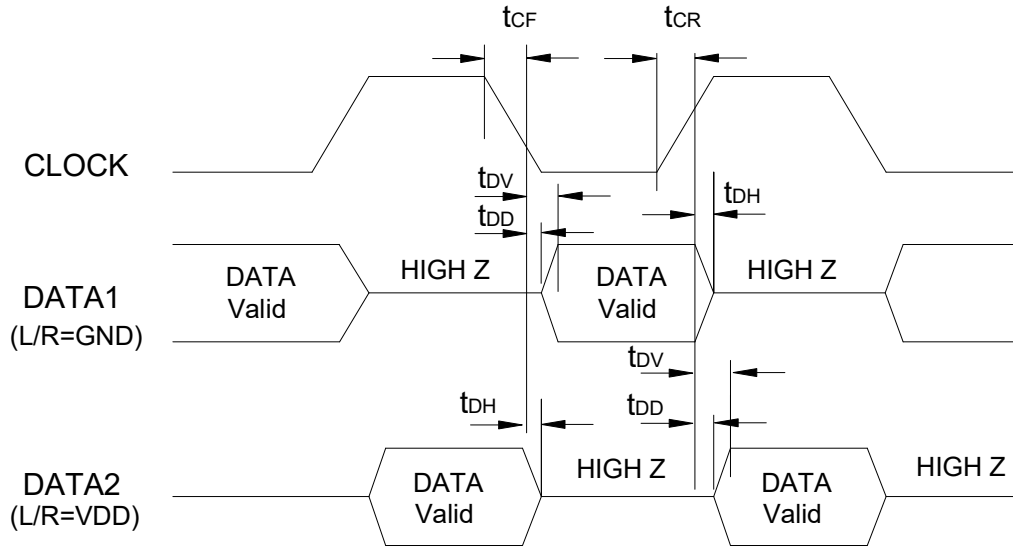

Fig. 2 Recommended timing diagram

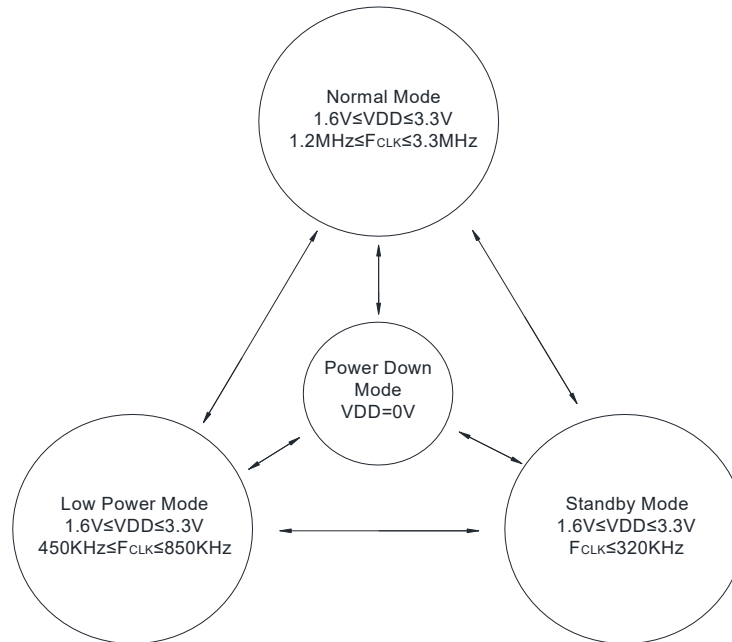

Fig. 3 State diagram

Performance Curves

All curves are tested under 1.8V,2.4MHz unless otherwise noted.

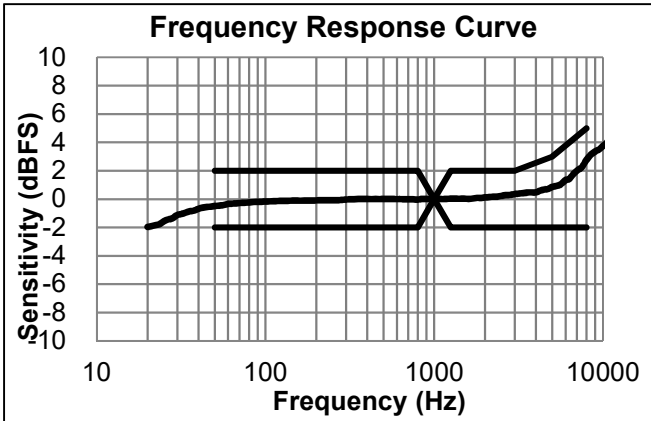

Fig. 4 Normal mode FR normalized to 1kHz

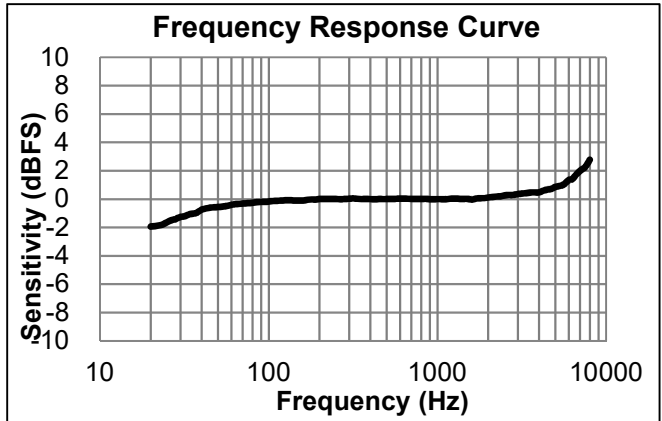

Fig.5 Low power mode FR normalized to 1kHz

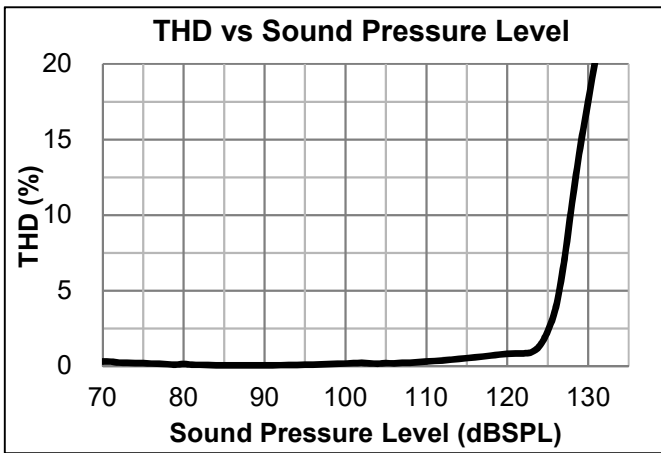

Fig. 6 Typical THD vs Sound Pressure Level

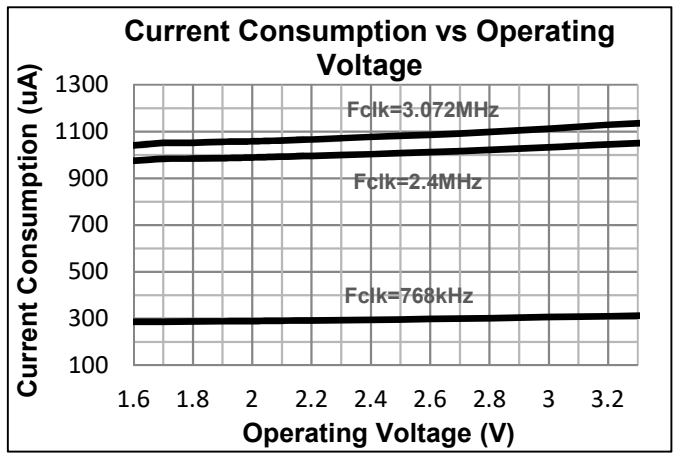

Fig. 7 Typical Current Consumption curve

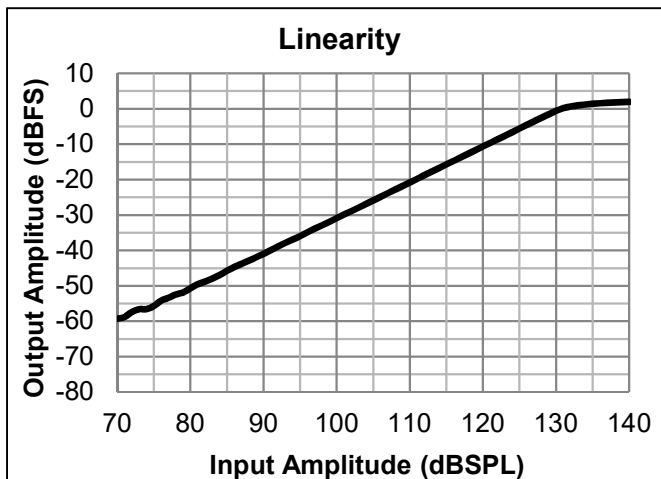

Fig. 8 Linearity

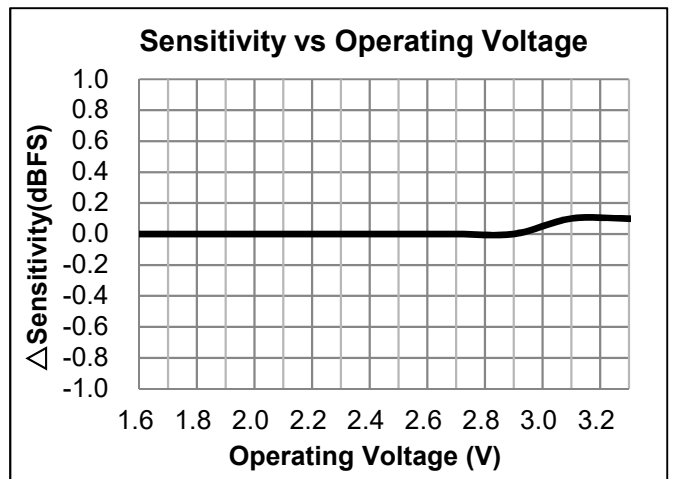

Fig. 9 Sensitivity vs operating voltage

Measurement System Setup

Test signal: Sinusoid, Sweep,
Step: 1/12 octave

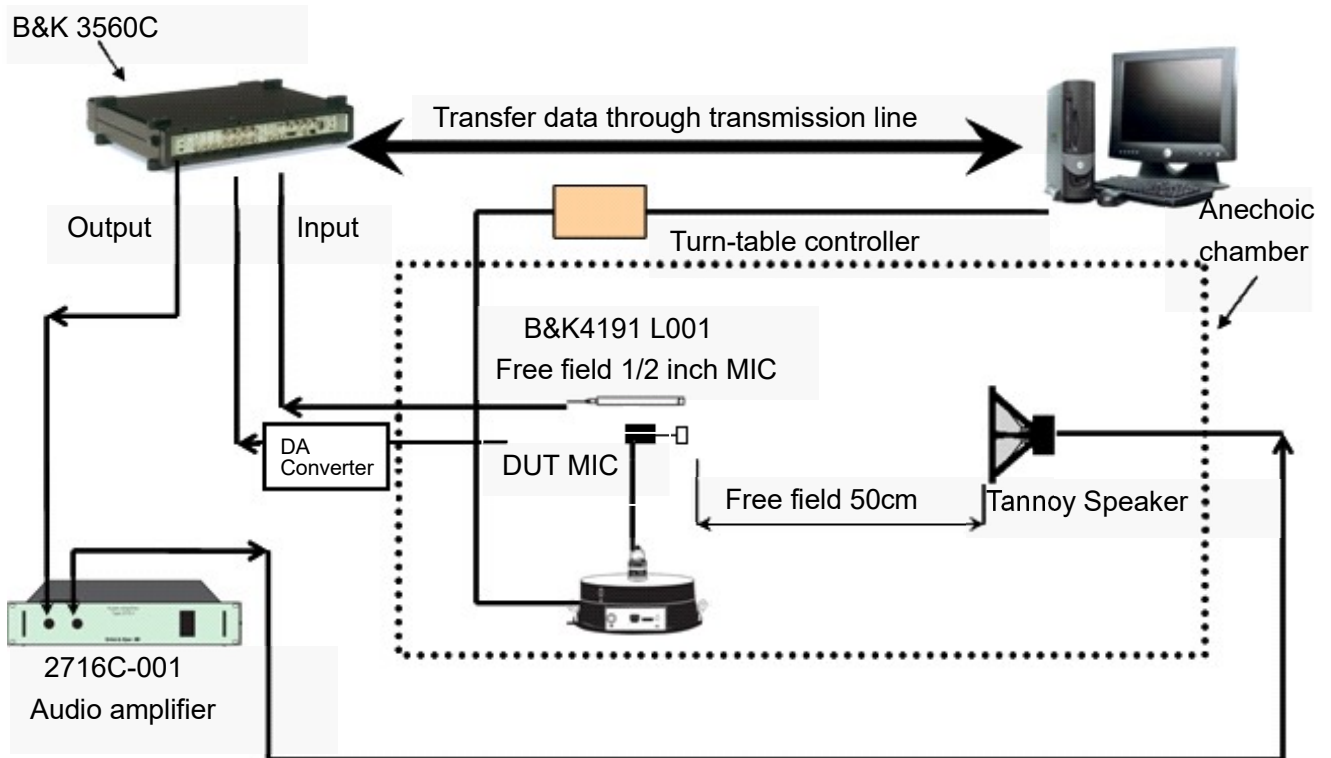

Fig. 10 Measurement System Setup

Typical Application Circuit

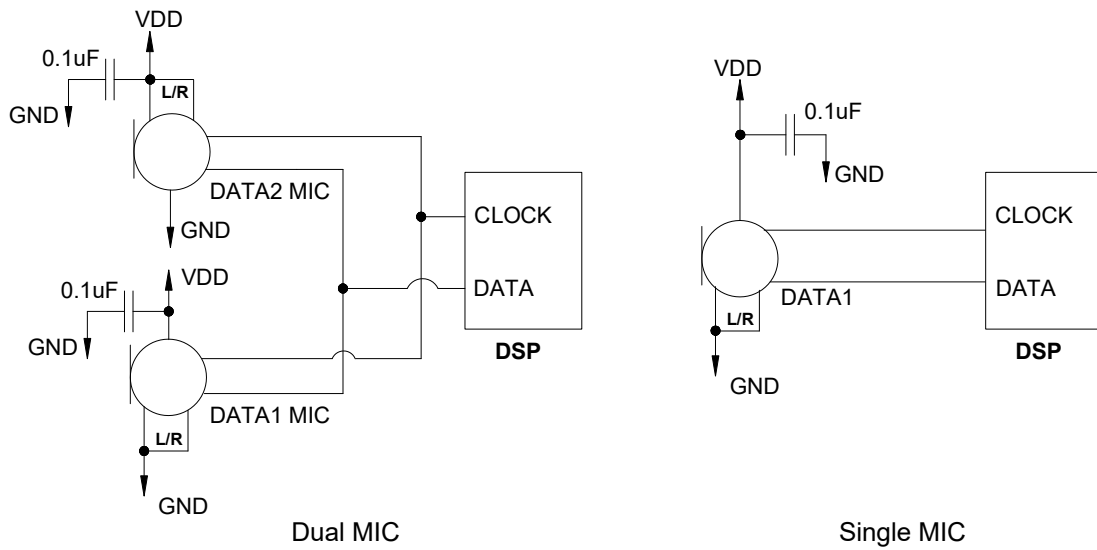

Fig. 11 Recommended interface circuit

Note1: A 0.1uF ceramic type decoupling capacitor is strongly recommended for every microphone and it should be placed as close to the VDD pad to reduce the noise on power supply; The trace connected to each pad of capacitor should be as short as possible, and should stay on one layer of PCB without via. For the best performance, recommend to place the capacitor equidistance from power and ground pins of microphone, or slightly closer to the power pin if space not allowed. System ground should connect to far side of the capacitor, as shown in fig.12.

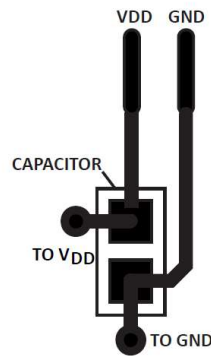
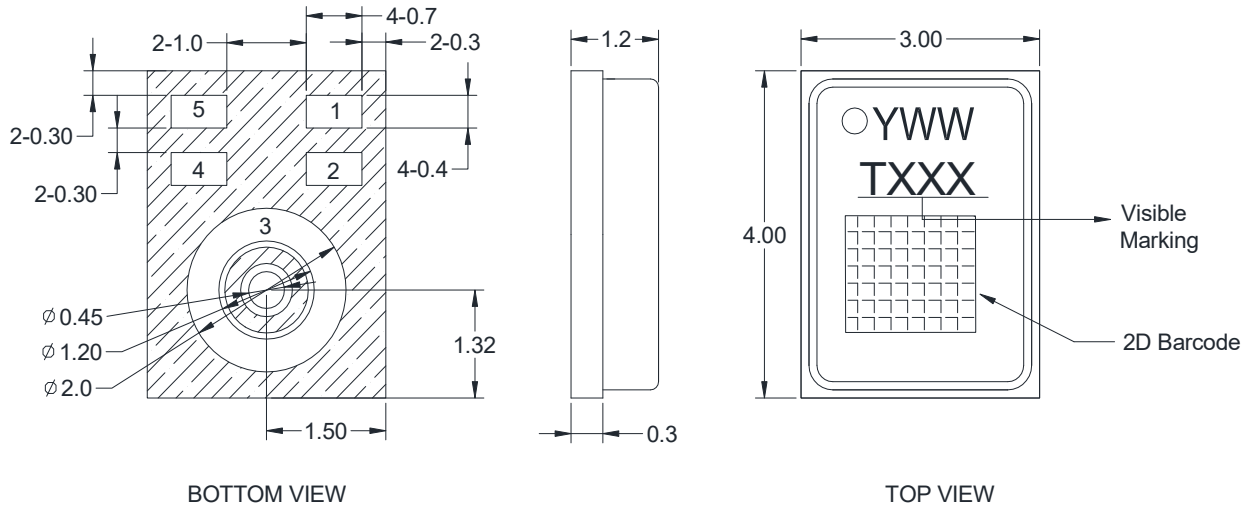

Fig. 12 Recommended Power Supply Decoupling Capacitor Layout

Note2: Do not use a pull-up or pull-down resistor on the PDM data signal line, because it can pull the signal to an incorrect state during the period that the signal line is restarted.

Note3: When long wire is used to connect the CLK of codec and microphone, a 50~100 Ω resistor should be placed near the codec to reduce signal over-shoot or ringing.

Mechanical Specifications



Unit: mm Unmarked Tolerance: ± 0.1 (mm)

Fig. 13 Dimension

Item	Dimension	Tolerance
Length	4.0	± 0.1
Width	3.0	± 0.1
Height	1.2	± 0.1
Acoustic Port	0.45	± 0.05

PIN	Definition	Description
1	CLK	Clock input
2	L/R	L/R select (No internal pull-down. Must be connected to VDD or GND)
3	GND	Ground
4	VDD	Power Supply
5	DATA	PDM Output

Note:

- The L/R pin is suggested to connect to GND during single mic application.
- Identification Marking

○: Polarity sign Y: Year WW: Week

T: GETTOP XXX: Serial Number



2D Barcode

Reliability Tests

After conducting any of the following tests, the sensitivity change of DUT shall be less than $\pm 3\text{dB}$ from its initial value unless otherwise noted, and shall keep its initial operation and appearance.

Table 7 Reliability Specifications

No.	Item	Test condition
1	Preconditioning	24 hour bake at 125°C, followed by 168 hours at 85°C, 85%RH, followed by 3 passes solder reflow only for the following three tests: High Humidity & High Heat operating Test High Humidity & High Heat operating Test Thermal Shocking Test
2	Hi-Temperature Storage Test	105 \pm 3°C, 1000h, recover for two hours
3	Hi-Temperature operating Test	105 \pm 3°C, under upper limit bias, 1000h, recover for two hours
4	Low-Temperature storage Test	-40 \pm 3°C, 1000h, recover for two hours
5	Low-Temperature operating Test	-40 \pm 3°C, under upper limit bias, 1000h, recover for two hours
6	High Humidity & High Heat operating Test	85 \pm 3°C, 85%RH, under upper limit bias, 1000h, recover for two hours, there should be no corrosion and deformation inside of microphone after testing
7	High Humidity & High Heat operating Test	65 \pm 3°C, 95%RH, under upper limit bias, 168h, recover for two hours, there should be no corrosion and deformation inside of microphone after testing
8	Thermal Shocking Test	Double-Case Method, -40°C for 15mins \rightarrow 125°C for 15 mins, 100 cycles, recover for two hours
9	Vibration Test	Each 12mins for X, Y and Z axes, Frequency: 20~2000Hz, Peak Acceleration 20g, recover for two hours
10	Drop Test	Height: 1.5m Fixture Weight: 150g (Holes diameter on the fixture in the sound hole location \geq 0.8mm) Reference Surface: slippery marble floor Duration: 4 corners*4 times, 6 faces*4 times The sensitivity change should be less than 1dB after testing
11	Tumbling Test	Height: 1.0m Fixture Weight: 150g (Holes diameter on the fixture in the sound hole location \geq 0.8mm) Duration: 300 times Recommended Time: 10-11times/Min The sensitivity change should be less than 1dB after testing

12	ESD Test 1	<p>a. HMB Discharge Position: I/O pins Charge Voltage: $\pm 3000V$ Discharge Network: 100pF & 1500Ω</p> <p>b. CDM Discharge Position: I/O pins Charge Voltage: $\pm 250V$</p>
13	ESD Test 2	<p>The tests are performed acc. to IEC61000-4-2 level 3:</p> <p>a. Contact Discharge Discharge Position: Output of Microphone Charge Voltage: $\pm 6000VDC$ Discharge Network: 150pF & 330Ω</p> <p>b. Air Discharge Discharge Position: Sound Hole Charge Voltage: $\pm 8000VDC$ Discharge Network: 150pF & 330Ω</p>
14	Structure Shock Test	10000g, Duration: 0.1ms, each 3 shocks for X/Y/Z 3 axes, The sensitivity change should be less than 1dB after testing
15	Reflow	3 reflow cycles with peak temperature of +260 $^{\circ}C$ according to reflow profile

Packaging Details

- * Use ESD reel and tape for microphone packaging.
- * Anti-static measures should be applied during packaging operation.

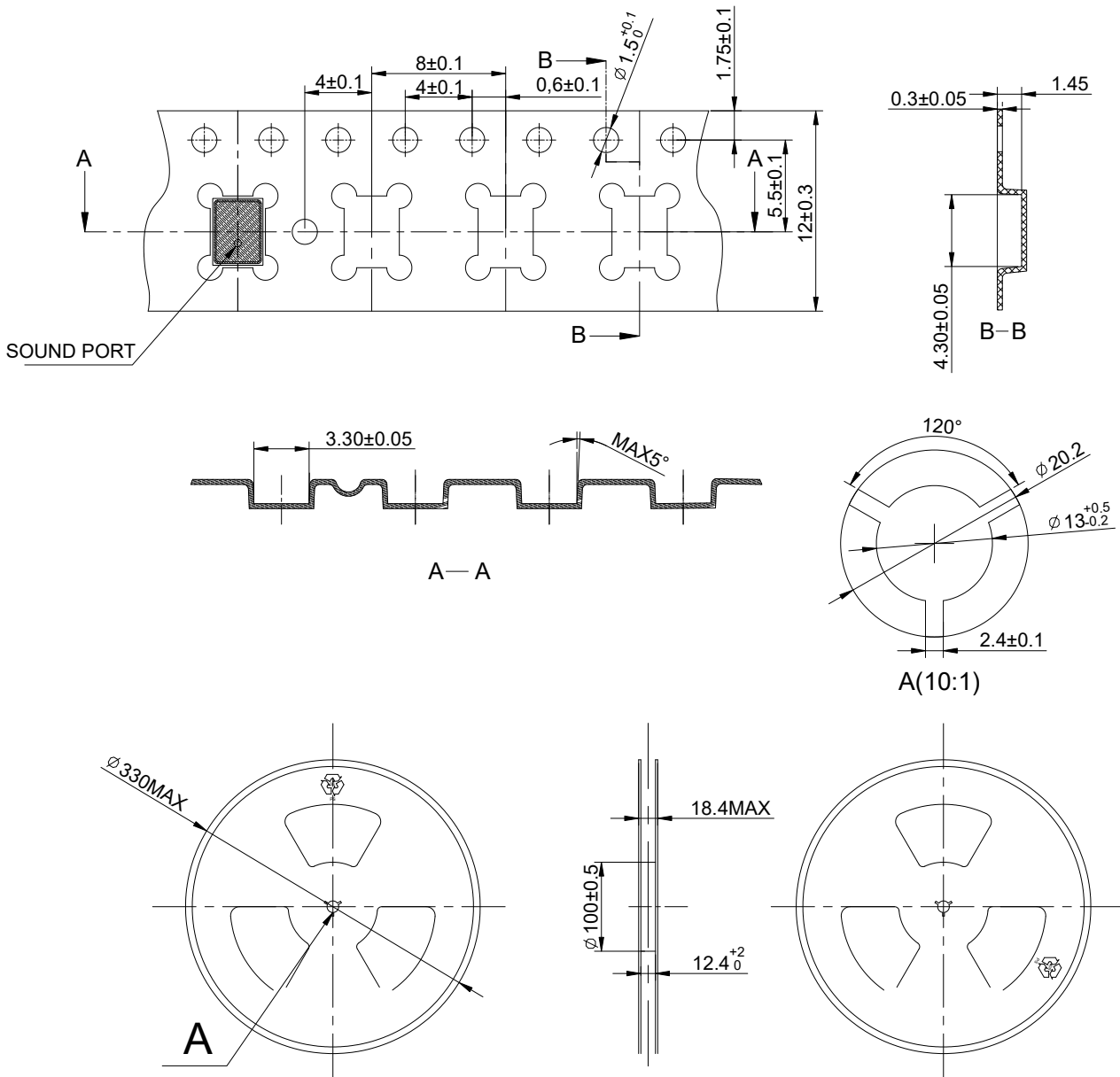
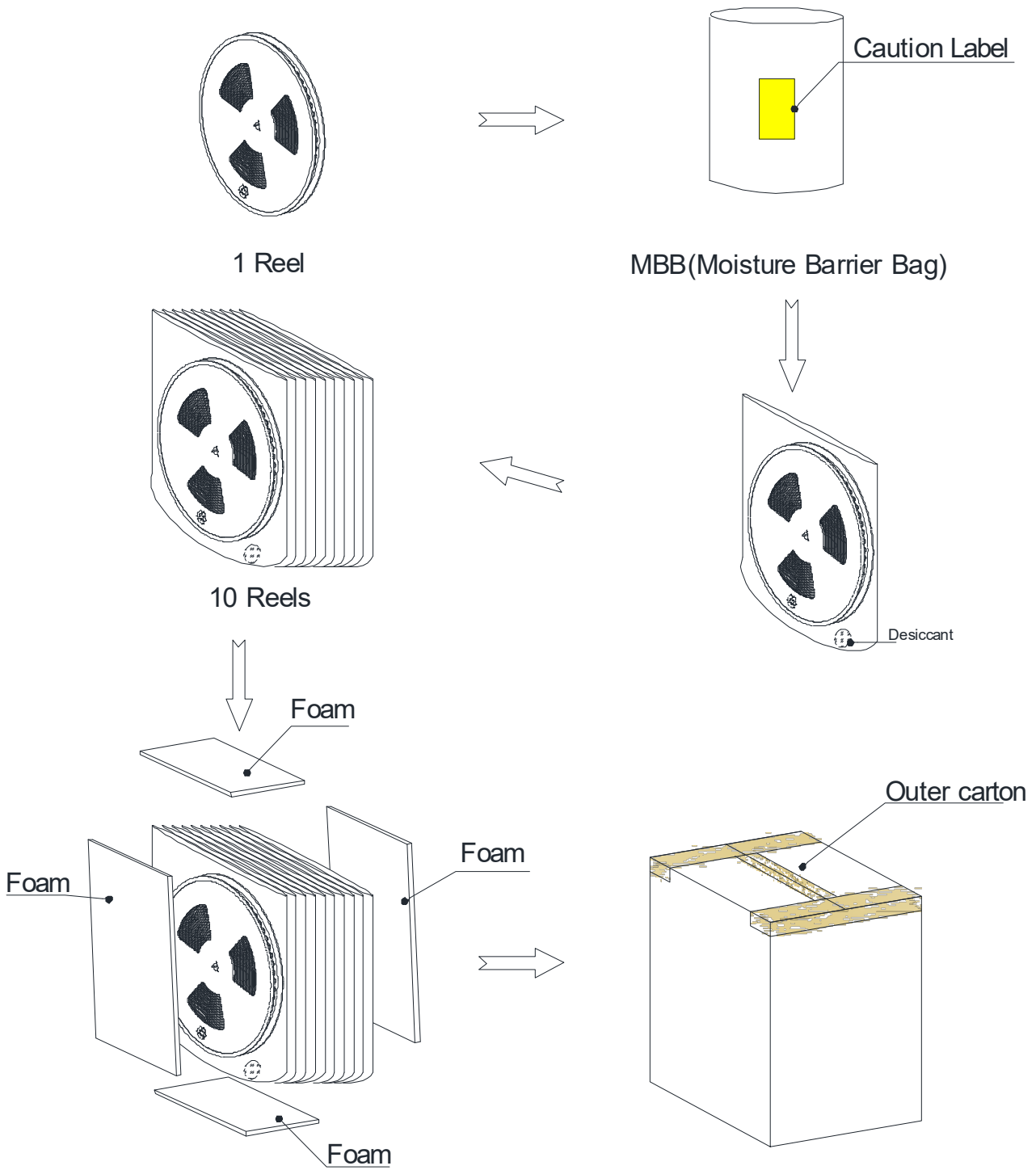

Fig. 14 Packaging



Tape and Reel	φ330mm	4,500PCS×1=4,500PCS
Shipping Box	215mm*370mm*370mm	4,500PCS×10=45,000PCS

Application Design Suggestions

Recommended PCB and Stencil Design Pattern

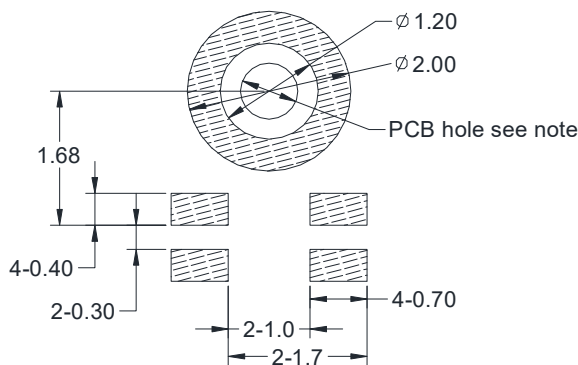

Example Land Pattern

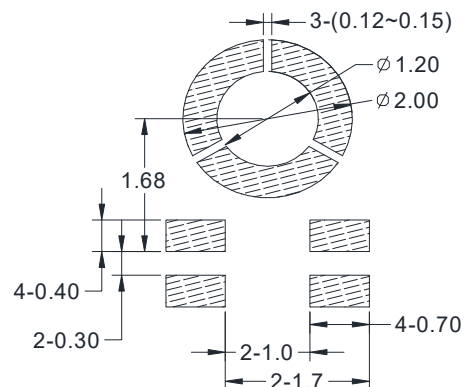

Example Solder Stencil Pattern

Notes:

- Dimensions are in millimeters unless otherwise specified.
- Tolerance is $\pm 0.1\text{mm}$ unless otherwise specified.
- The recommended non-plated hole diameter of PCB is 0.7-0.9mm.

Temperature Profile during Reflow Process

Table 8 Temperature Profile during Reflow Process

Parameter	Reference	Specification
Average Ramp Rate	T_L to T_P	3°C/sec max
Preheat	Minimum Temperature	T_{SMIN}
	Maximum Temperature	T_{SMAX}
	Time T_{SMIN} to T_{SMAX}	t_s
Ramp-Up Rate	T_{SMAX} to T_L	1.25°C/sec
Time Maintained Above Liquidous	t_L	60 sec to 150 sec
Liquidous Temperature	T_L	217°C
Peak Temperature	T_P	260°C
Time Within +5°C of Actual Peak Temperature	t_p	20 sec to 40 sec
Ramp-Down Rate	T_P to T_{SMAX}	6°C/sec max
Time +25°C ($t_{25^\circ\text{C}}$) to Peak Temperature		8 min max

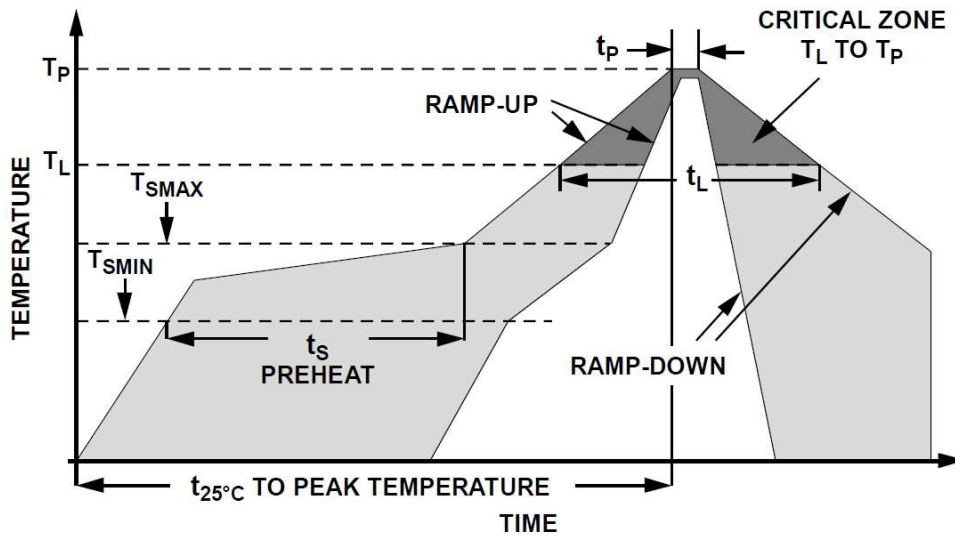

Fig. 15 Reflow Profile

Additional Notes:

- Mic should cool to room temp before next flow cycle if more reflow is needed.
- No more than 3 times reflow is recommended.
- Do not board wash by liquid or ultrasonic after the reflow process.
- Do not pull a vacuum over port hole of the microphone.
- Do not insert any object in port hole of device at any time.
- Suggest SMT the microphone at last time if double side PCBA used.
- Do not seal sound port during reflow .
- If there is any leakage risk, the peak temperature should be set to less than 240°C or more than 255°C.

Recommended nozzle for reflow MIC

External diameter is $\Phi 1.8\text{mm}$

Inside diameter is $\Phi 1.2\text{mm}$

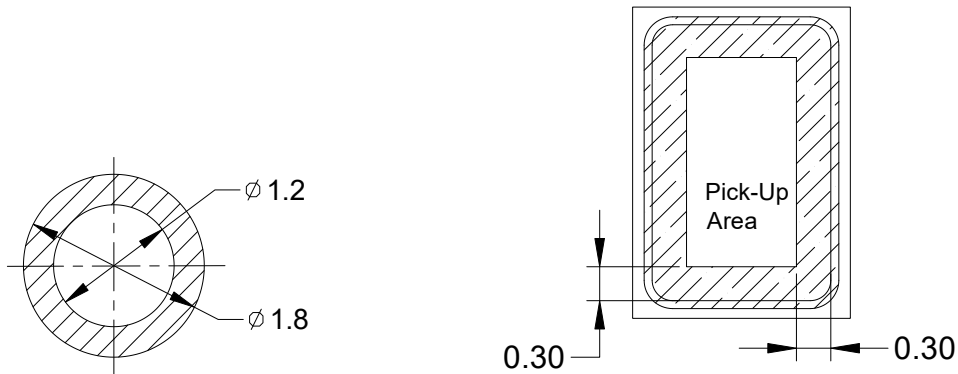

Fig. 16 Recommended nozzle for reflow MIC and Pick-up Area

Special Cautions

Air Rifle Cleaning Restriction

Do not bring air rifle to the port hole directly.

Recommended Condition:

Air pressure < 0.3MPa;

Distance > 5cm;

Time < 5 sec.

Package

Do NOT vacuum seal unused material for storage. Vacuum Sealing can cause mic damage.

Storage

The component needs to meet the requirement of MSL(Moisture Sensitivity Level) class 1. Please keep MICs in warehouse with humidity less than 75% and without sudden temperature change, acid air, and any other harmful air or strong magnetic field.

Please protect products against moist, shock, sunburn and pressure.

Please take proper measures against ESD in the process of assembly and transportation.

Please use the shipping package for long-term storage.

Discard

For microphones to be wasted, customer shall follow the regulation of Waste Electrical and Electronic Equipment (WEEE) Directive (2002/96/EC).

Notes: More application suggestions can be found in the latest "MEMS Microphone Application Notes".

