

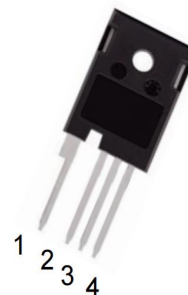

1.Features

- V_{DS} 650V
- I_D 77A
- $R_{DS(ON)}$ 40 mΩ

TO-247-4



2.Mechanical Data

- Case:Molded Plastic,TO-247-4;
- Epoxy:UL 94V-0 rate flame retardant
- Terminals:Plated Leads Solderable per MIL-STD-750,Method-2026.
- Marking: marked on body.
- Mounting Position : Any.

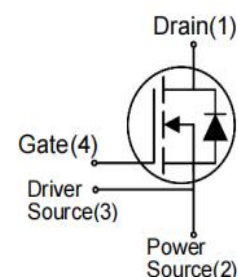

3.Maximum Ratings and Electrical Characteristics

Rating at 25°C Cambient temperature unless otherwise specified

Characteristics		Symbol	Ratings	Unit
Drain-Source Voltage		V_{DS}	650	V
Drain Current Continuous	$T_C=25^{\circ}C$	I_D	77	A
	$T_C=100^{\circ}C$		55	
PeakDrain Current		I_{DM}	150	A
Gate-Source Voltage		V_{GSmax}	-8/+22	V
Recommend Gate-Source Voltage		V_{GSop}	-4/+18	V
Power Dissipation	$T_C=25^{\circ}C$	P_{tot}	283	W
	$T_C=100^{\circ}C$		141	
Maximum Junction Temperature		T_J	-40~175	°C
Storage Temperature Range		T_{stg}	-40~175	°C
Thermal Resistance from Junction to Case		$R_{th(j-c)}$	0.55	°C/W



Characteristics	Symbol	Test conditions	Min	TYP	Max	Unit	
Static Characteristics							
Drain -Source Breakdown Voltage	BV_{DSS}	$V_{GS}=0V, I_D=0.1mA$	650	-	-	V	
Zero Gate Voltage Drain Current	I_{DSS}	$V_{DS}=650V, V_{GS}=0V$	-	1	-	μA	
Gate-Source Leakage Current	I_{GSS}	$V_{GS}=0V, V_{DS}=18V$	-	-	250	nA	
Gate Threshold Voltage	$T_j=25^\circ C$	$V_{GS(th)}$	$V_{GS}=V_{DS}, I_D=10\mu A$	2.0	2.50	4.0	V
	$T_j=150^\circ C$			-	1.63	-	
	$T_j=175^\circ C$			-	1.60	-	
Drain-Source On-State Resistance	$T_j=25^\circ C$	$R_{DS(on)}$	$V_{GS}=18V, I_D=30A$	-	36	-	m Ω
	$T_j=175^\circ C$			-	43	-	
Dynamic Characteristics							
Input Capacitance	C_{iss}	$V_{DS}=600V$	-	2200	-	pF	
Output Capacitance	C_{oss}	$V_{GS}=0V$	-	200	-		
Reverse Transfer Capacitance	C_{riss}	$f=1MHz$	-	14	-		
Total Gate Charge	Q_g	$V_{DS}=400V, V_{GS}=-4/18V$ $I_D=30A$	-	113	-	nC	
Gate-Source Charge	Q_{gs}		-	29	-		
Gate-Drain Charge	Q_{gd}		-	43	-		
Switching Characteristics							
Turn-on Delay Time	$t_{d(on)}$	$V_{DD}=400V, V_{GS}=4V/18V$ $I_D=20A, R_G=2.5\Omega$	-	27	-	ns	
Turn-on Rise Time	t_r		-	21	-		
Turn-off Delay Time	$t_{d(off)}$		-	27	-		
Turn-off Fall Time	t_f		-	11	-		
Turn-On Energy	E_{on}		-	156	-	μJ	
Turn-Off Energy	E_{off}		-	21	-		
Drain-Source Diode Characteristics							
Diode Forward Voltage	$T_j=25^\circ C$	V_{SD}	$V_{GS}=-4V, I_{SD}=30A$	-	5.6	-	V
	$T_j=175^\circ C$			-	4.68	-	
Continuous Diode Forward Current	$T_j=25^\circ C$	I_S	$V_{GS}=-4V$	-	45	-	A
	$T_j=100^\circ C$			-	20	-	
Reverse Recovery Time	T_{rr}	$V_{GS}=-4V, I_{SD}=20A,$ $V_R=400V,$ $di/dt=900A/\mu s, T_j=25^\circ C$	-	15	-	ns	
Reverse Recovery Charge	Q_{rr}		-	100	-	nC	
Peak reverse recovery current	I_{rrm}		-	13	-	A	



4. Rating And Characteristic Curves

Fig.1 Output Characteristics $T_j = -40^\circ\text{C}$

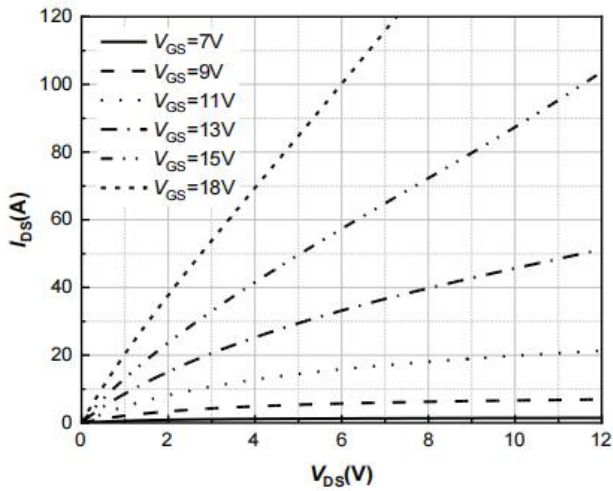

Fig.2 Output Characteristics $T_j = 25^\circ\text{C}$

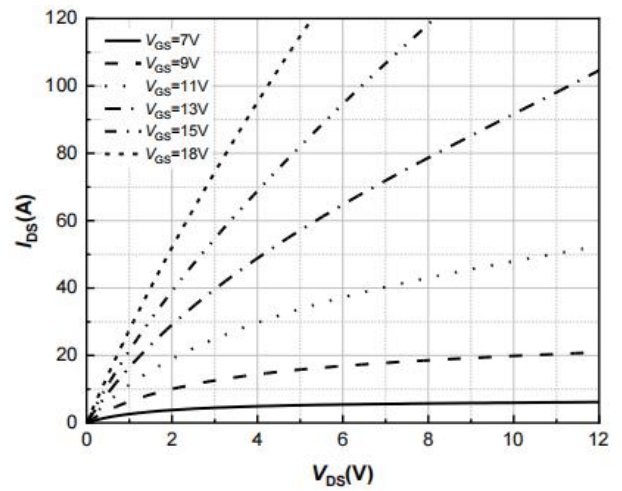

Fig.3 Output Characteristics $T_j = 175^\circ\text{C}$

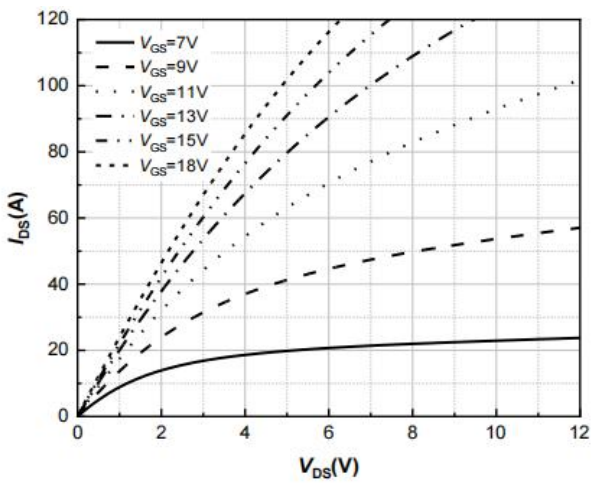

Fig.4 Normalized $R_{DS(on)}$ DS vs. Temperature

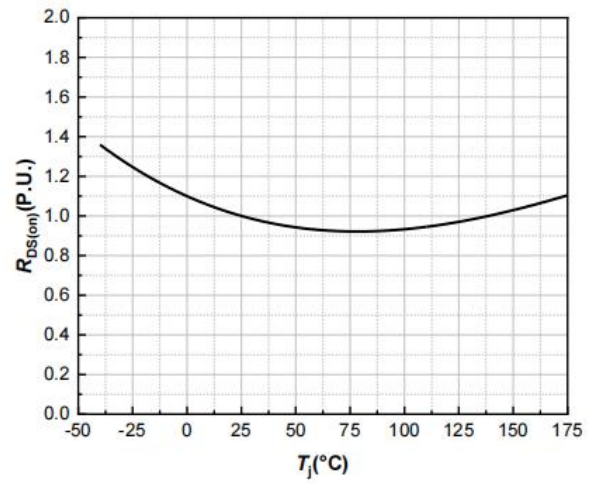

Fig.5 I_{DS} (A) VS $R_{DS(on)}$

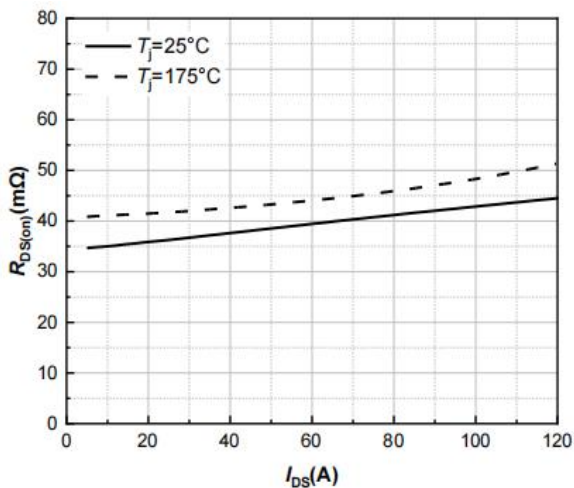

Fig.6 I_{DS} (A) VS T_j ($^\circ\text{C}$)

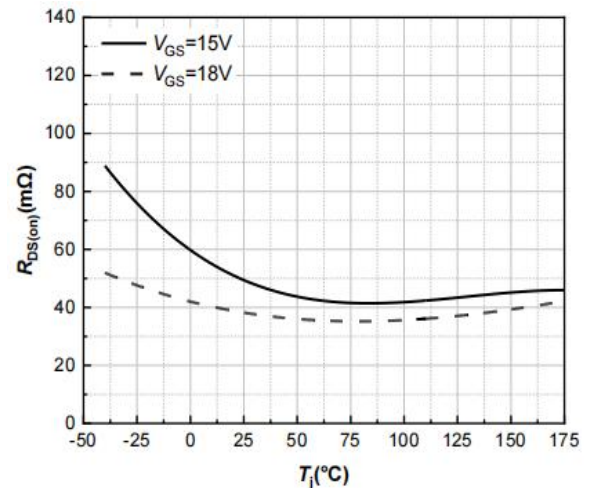



Fig.7 V_{GS} vs I_{DS} (A)

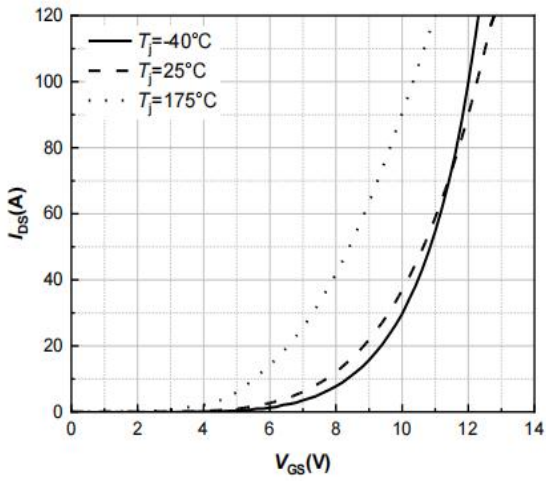

Fig.8 Body Diode Characteristic $T_j = -40^\circ\text{C}$

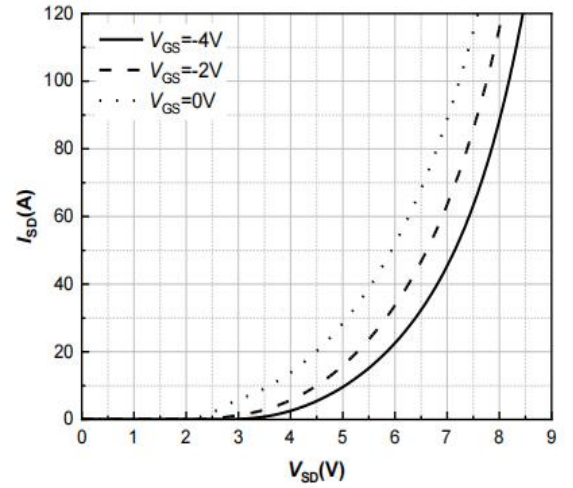

Fig.9 Body Diode Characteristic $T_j = 25^\circ\text{C}$

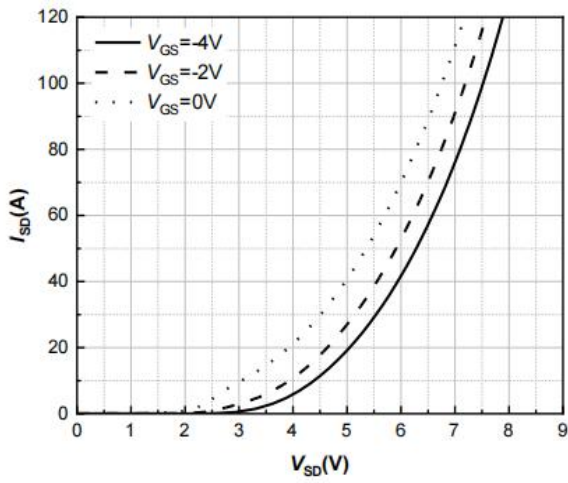

Fig.10 Body Diode Characteristic $T_j = 175^\circ\text{C}$

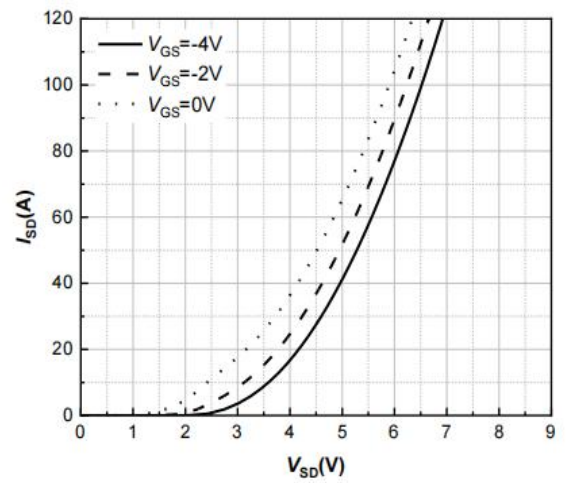

Fig.11 Threshold Voltage vs. Temperature

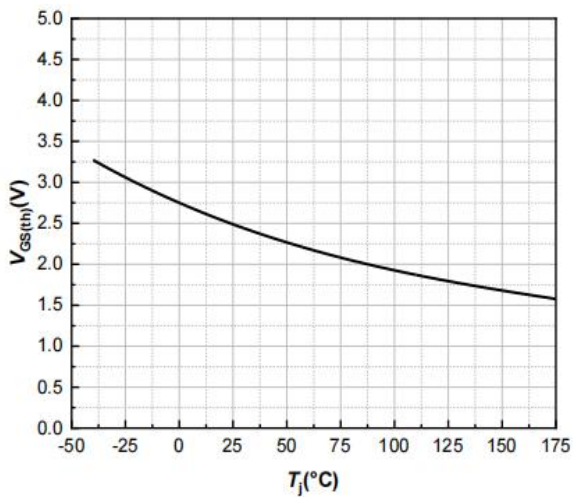

Fig.12 Gate Charge Characteristics

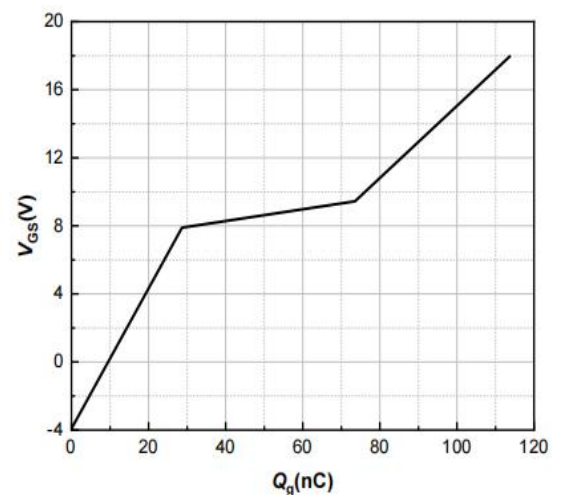



Fig.13 3rd Quadrant Characteristic $T_j=-40^{\circ}\text{C}$

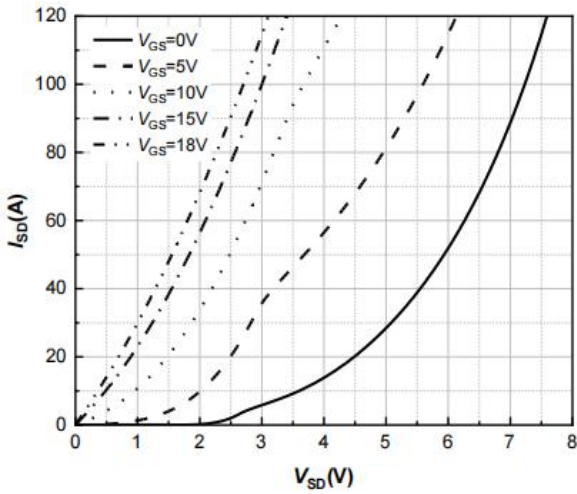

Fig.14. 3rd Quadrant Characteristic $T_j=25^{\circ}\text{C}$

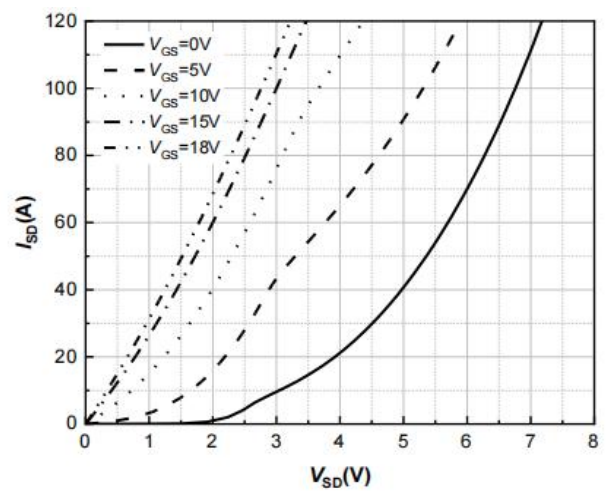

Fig.15 3rd Quadrant Characteristic

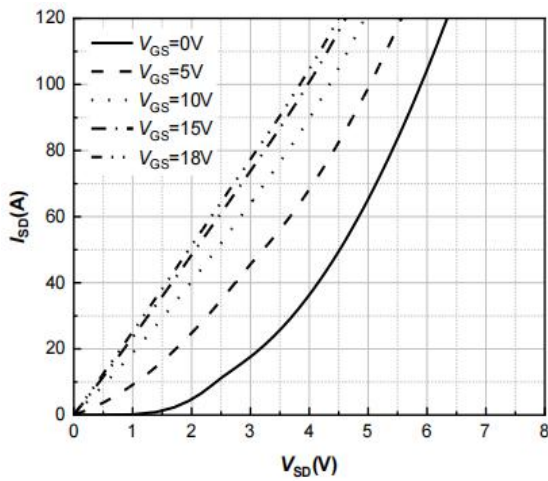

Fig.16 Output Capacitor Stored Energy

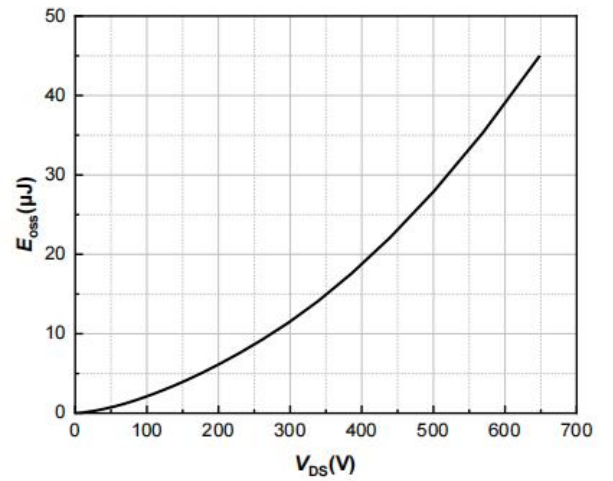

Fig.17 Capacitances vs. Drain-Source

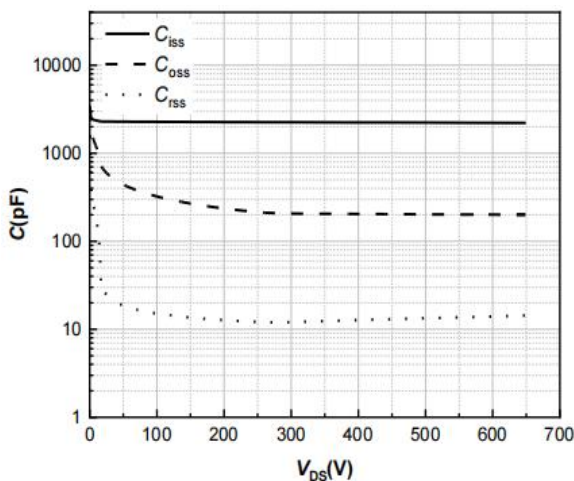

Fig.18 $I_{DS}(\text{A})$ vs. $T_c(^{\circ}\text{C})$

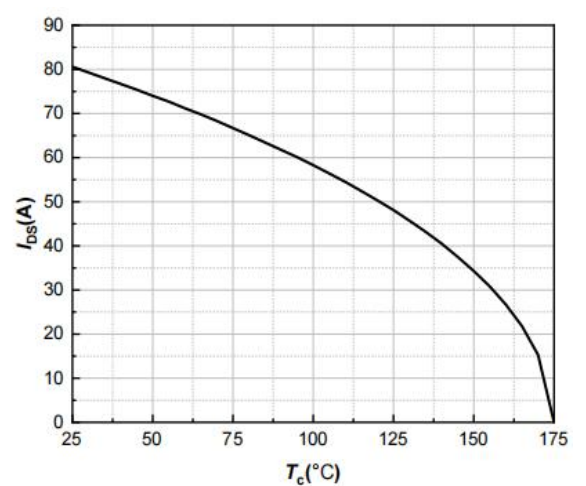



Fig.19 $P_{tot} t$ vs $T_c(^{\circ}C)$

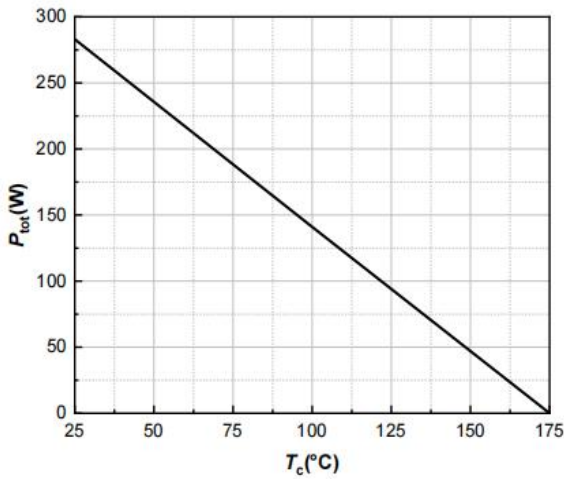

Fig.20 Transient Thermal Impedance

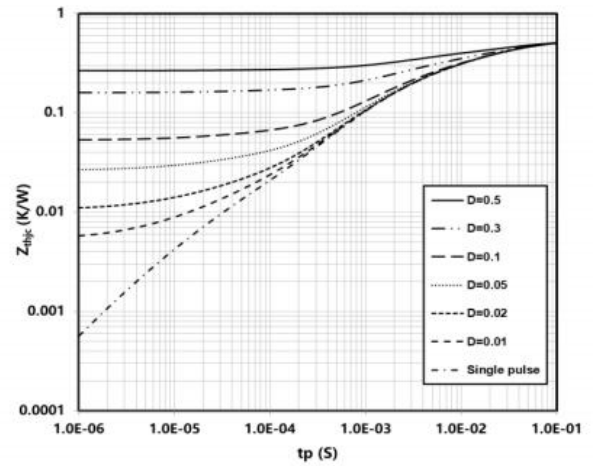

Fig.21 Clamped Inductive Switching Energy vs. Drain Current

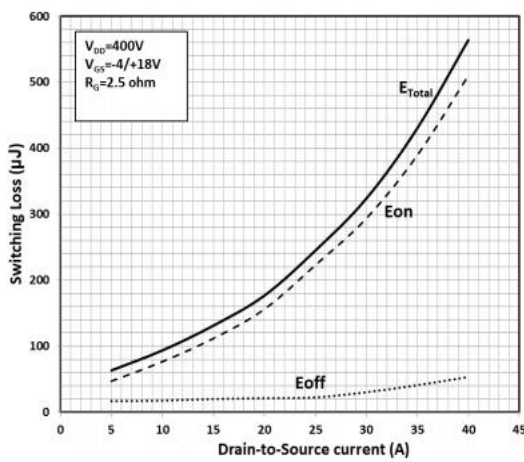

Fig.22 Clamped Inductive Switching Energy vs. R_G

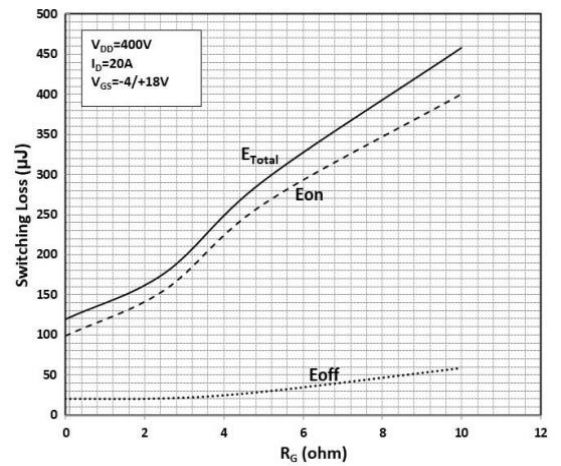

Fig.23 Switching Times vs. R_G

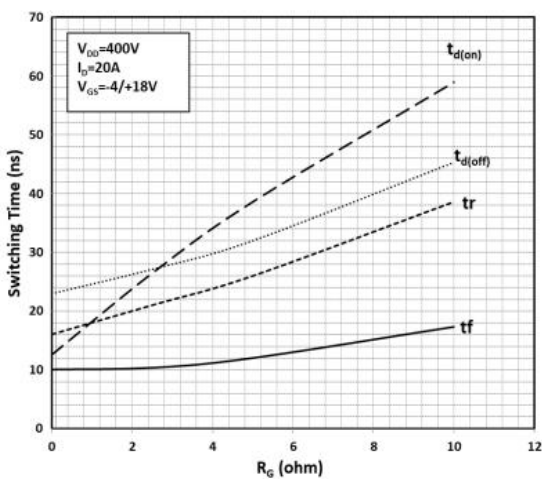
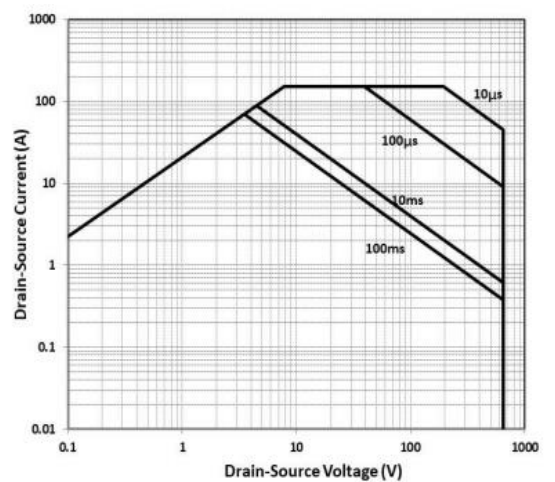

Fig.24 Safe Operating Area





SC040N065J4

650V 77A N-CHANNEL POWER MOSFET

5. Dimensions

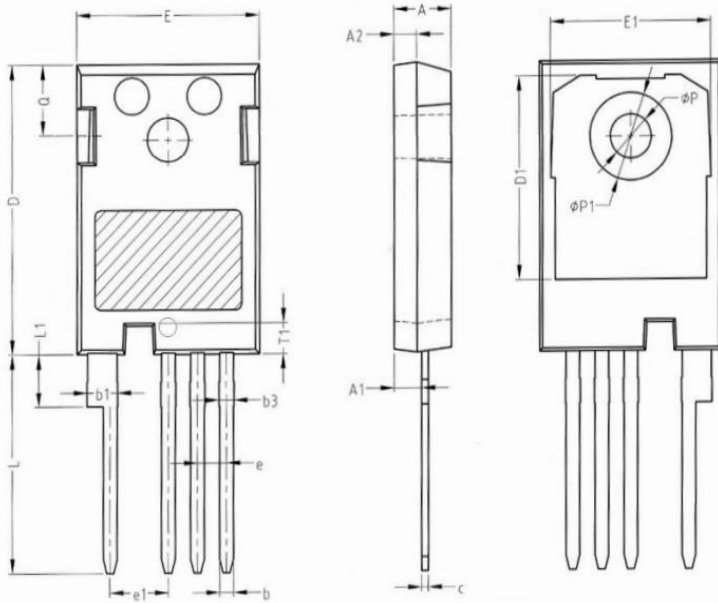

DIM	Unit(inch)		Unit(mm)	
	MIN	MAX	MIN	MAX
A	0.189	0.205	4.80	5.20
A1	0.087	0.103	2.21	2.61
A2	0.071	0.087	1.80	2.20
b	0.042	0.054	1.06	1.36
b1	0.092	0.115	2.33	2.93
b3	0.042	0.063	1.07	1.60
c	0.020	0.030	0.51	0.75
D	0.917	0.929	23.30	23.60
D1	0.640	0.663	16.25	16.85
E	0.620	0.635	15.74	16.14
E1	0.540	0.564	13.72	14.32
T1	0.093	0.104	2.35	2.65
e	2.54 BSC			
e1	5.08 BSC			
Q	0.216	0.240	5.49	6.09
L	0.680	0.704	17.27	17.87
L1	0.157	0.173	3.99	4.39
θp	0.134	0.150	3.40	3.80
θp1	7.19 REF			

6. Part Marking System

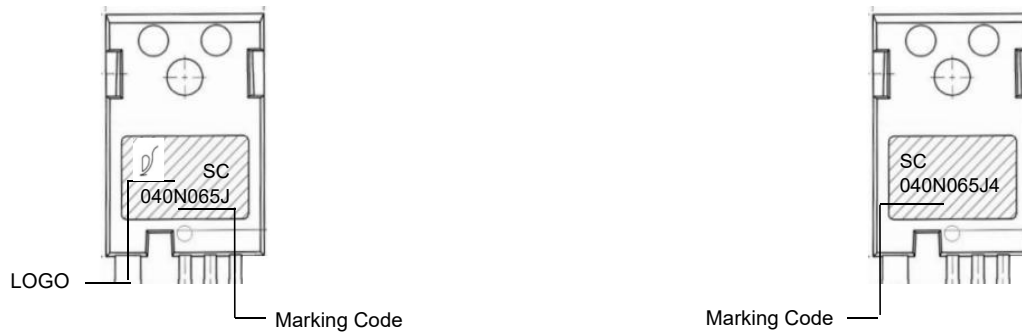

7. Package Information

Package	Packing Type	Quantity(pcs)
TO-247	Tube	25



Important Notice and Disclaimer

- Reproducing and modifying information of the document is prohibited without from XINNUO.
- XINNUO reserves the right to make changes to this document and its products and specifications.
- XINNUO disclaims any and all liability arising out of the application or use of any product including damages incidentally and consequentially occurred.
- XINNUO does not assume any and all implied warranties, including warranties of fitness for particular purpose, non-infringement and merchantability.
- Applications shown on the here in document are examples of standard use and operation. Customers are responsible in comprehending the suitable use in particular applications.XINNUO makes no representation or warranty that such applications will be suitable for the specified use without further testing or modification.
- The products shown her are not designed and authorized for equipments requiring high level of reliability or relating to human life and for any applications concerning life-saving or life-sustaining, such as medical instruments, transportation equipment, aerospace machinery et cetera. Customers using or selling these products for use in such applications do so at their own risk and agree to fully indemnify XINNUO for any damages resulting from such improper use or sale.
- Since XINNUO uses lot number as the tracking base, please provide the lot number for tracking when complaining.