

High Voltage Wire-to-Board Connectors

MDF51 Series

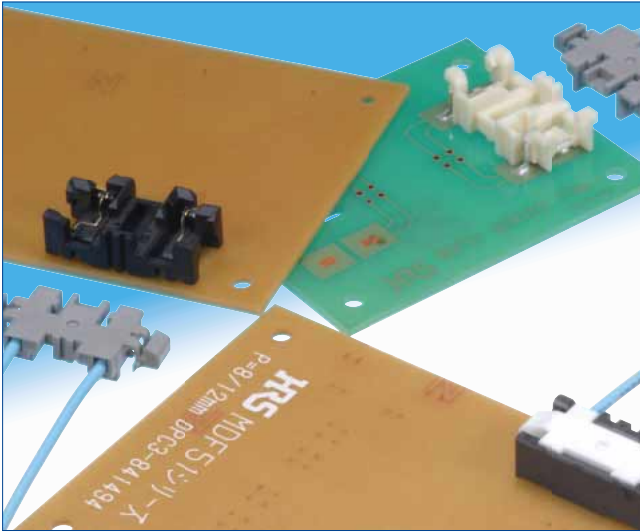

● Simple and secure mating with one push

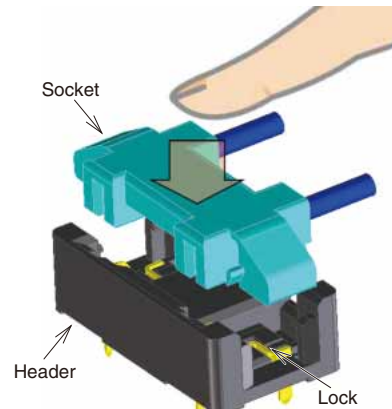

Fig.1

■ Features

1. Simple, one step mating

Built-in locks assure correct and complete mating with just a single, downward push on the plug.

2. Vertical mating style

The vertical mating style and built-in, self-aligning features are efficient and eliminates the need for additional space that would be required with a horizontal mating style connector.

3. Designed for high voltage applications

Wide contact pitch and creepage distance maintain stable and safe performance at high voltage levels.

4. Secure attachment to the board

Four solder points are provided to keep the headers firmly secured to the PCB.

5. Secure hold during the soldering operation.

The 12 mm pitch version incorporates a built in hold-down feature that helps keep the connector aligned during the soldering operation.

6. UL, C-UL, and TÜV certified (12mm pitch only)

7. RoHS compliant

■ Applications

LCD TV backlights, FPD power supplies and other applications requiring small high-voltage connectors.

● Secure hold during the soldering operation

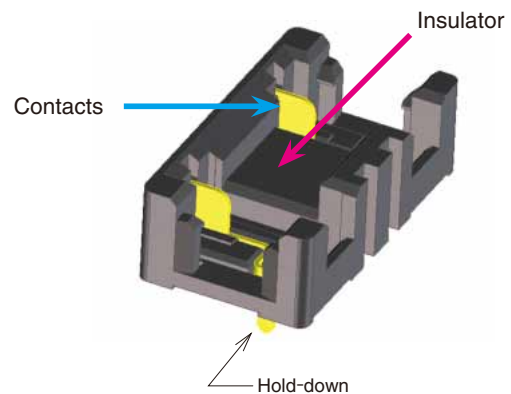

Fig.2

Product Specification

Ratings	Current rating	1A	Operating temperature range	-35°C to +85°C (Note 1)
	Voltage rating	3000V AC/DC	Operating humidity range	RH 20% to 80%
			Storage temperature range	-10°C to +60°C (Note 2)
			Storage humidity range	RH 40% to 70% (Note 2)

		UL, C-UL	TÜV
Ratings	Current rating	1A	1A
	Voltage rating	1000V AC/DC	1000V AC/DC

File and recognition numbers:

UL and C-UL : E52653
TÜV : R50085755

Item	Specifications	Conditions
1. Insulation resistance	1000MΩ min.	500V DC
2. Withstanding voltage	No flashover or insulation breakdown	5000V AC / 1 minute
3. Contact resistance	20mΩ max.	20mV max., at 1mA .
4. Vibration	No electrical discontinuity of 1μs or longer No damaged, cracked or loose parts.	Frequency: 10 to 55Hz, single amplitude of 0.75mm, 10 cycles, 3 axis
5. Shock	No electrical discontinuity of 1μs or longer No damaged, cracked or loose parts.	Acceleration of 490 m/s ² , 11 ms duration, sine half-wave, 3 cycles in each of the 3 axis
6. Humidity	Contact resistance: 40mΩ max., Insulation resistance: 500MΩ min. No damaged, cracked or loose parts.	96 hours at of 40 ±2°C, and humidity of 90 to 95%
7. Temperature cycle	Contact resistance: 40mΩ max., Insulation resistance: 500MΩ min. No damaged, cracked or loose parts.	-55°C → 5 to 35°C → 85°C → 5 to 35°C Times: 30 min. → 3 min. → 2 min. to 3 min. → 30 min. → 2 min. to 3 min. 5 cycles
8. Mating cycles	Contact resistance: 40mΩ max. No damaged, cracked or loose parts.	30 cycles
9. Resistance to soldering heat	No deformation of components affecting performance	Reflow: At the recommended temperature profile (MDF51SU) Flow: Solder temperature 260°C, 10 seconds (MDF51K and MDF51SY) Manual soldering: 350°C for 3 seconds

Note 1 : Includes temperature rise caused by current flow.

Note 2 : The term "storage" refers to products stored for a long period prior to mounting and use.

The operating temperature and humidity range covers the non-conducting condition of installed connectors in storage, shipment or during transportation.

Material / Finish

Header

Part	Material	Finish	Remarks
Insulator	MDF51K PBT	Color : Black	UL94V-0
	MDF51SU : Polyamide	Color : Beige	
	MDF51SY : Polyamide	Color : Black	
Contact	Brass	Tin plating	_____

Crimp socket

Part	Material	Finish	Remarks
Socket Insulator	MDF51 : Polyamide	Color : White	UL94V-0
	MDF51SU : Polyamide	Color : Gray	
Crimp contact	Phosphor bronze	Tin plating	_____

■ Product Number Structure

● Header

MDF51 **#** – ***** **P** – **12** **DSA**

① ② ③ ④ ⑤ ⑥

① Series name : MDF51	③ No. of contacts : 2
② Configuration type K : Contact pitch 12mm, through hole SU : Contact pitch 13mm, surface mount SY : Contact pitch 13mm, through hole	④ Connector type P : Header
	⑤ Contact pitch 12mm or 13mm
	⑥ Mounting style DSA : Through hole, straight V : Surface mount, straight

● Crimp socket

MDF51 **#** – ***** **S** – **12** **C**

① ② ③ ④ ⑤ ⑥

① Series name : MDF51	③ No. of contacts : 2
② Configuration type Blank : Contact pitch 12mm, standard SU : Contact pitch 13mm, standard	④ Connector type S : Crimp socket
	⑤ Contact pitch 12mm or 13mm
	⑥ Termination C : Crimp

● Contacts

MDF51 – **24** **SCF**

① ②

① Applicable wire size 24 : 24 AWG	② Packaging SCF : Female crimp contact / reel
---------------------------------------	--

Header (Contact pitch : 12 mm)

- Straight, through hole

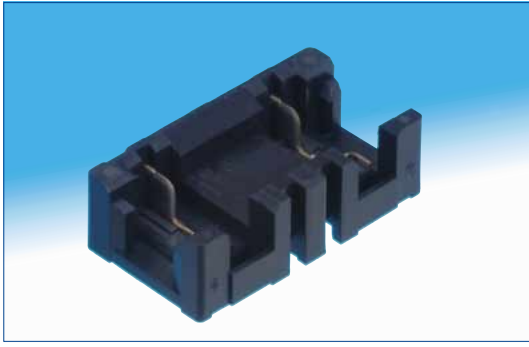

Recommended PCB layout dimensions (Thickness : 1.6mm)

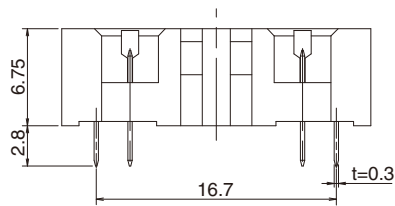
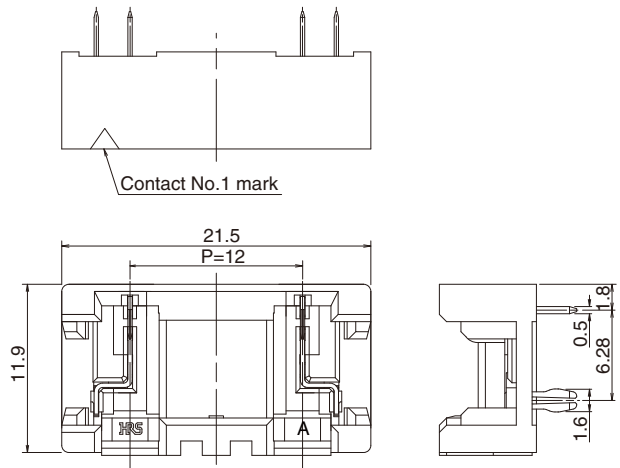
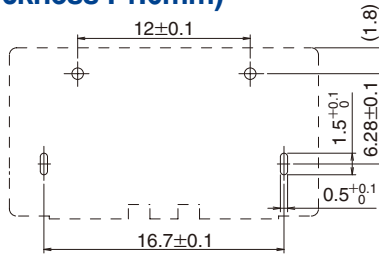

Unit : mm

● Packaging Specification

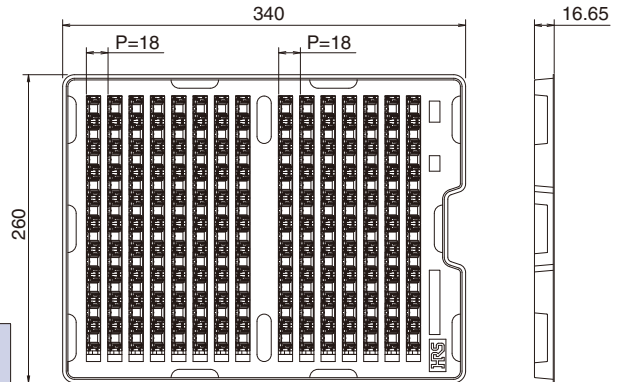

Part No.	HRS No.	No. of contacts	Insulator Color	Packaging
MDF51K-2P-12DSA(20)	547-2017-9 20	2	Black	150 pcs/tray

Please place orders in full tray increments.

Crimp socket (Contact pitch : 12 mm)



- With crimp contacts assembled

- Contacts supplied separately

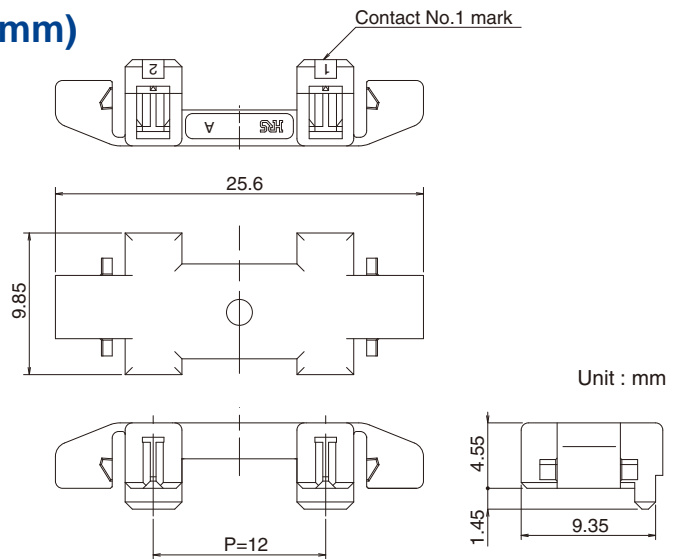

Part No.	HRS No.	No. of contacts	Insulator Color	Packaging
MDF51-2S-12C	547-2004-7 00	2	White	100 pcs/pack

Please place orders in full pack increments.

Header (Contact pitch : 13 mm)

●Straight, surface mount

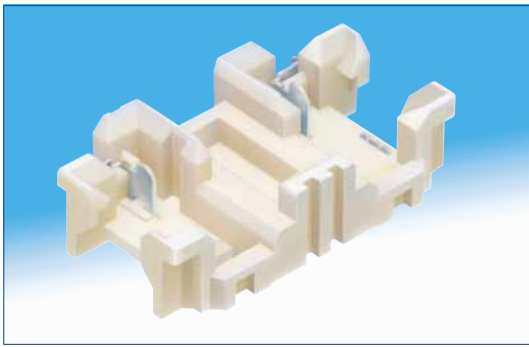

◆Recommended PCB layout dimensions

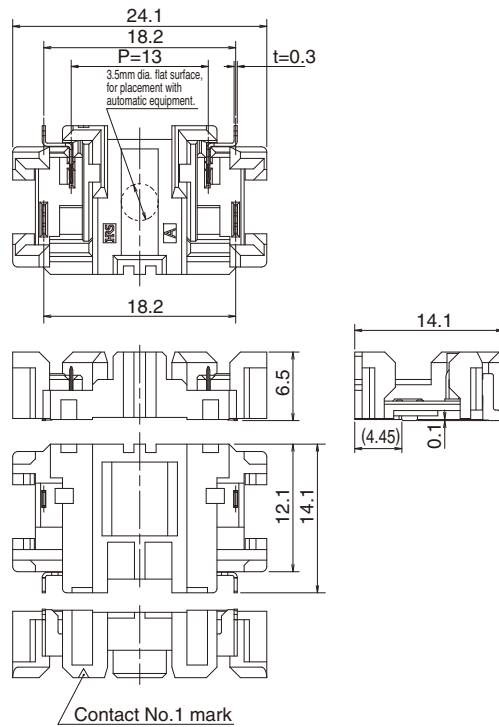
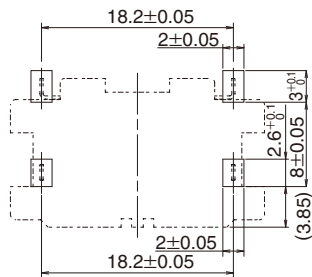

Unit : mm

●Packaging Specification

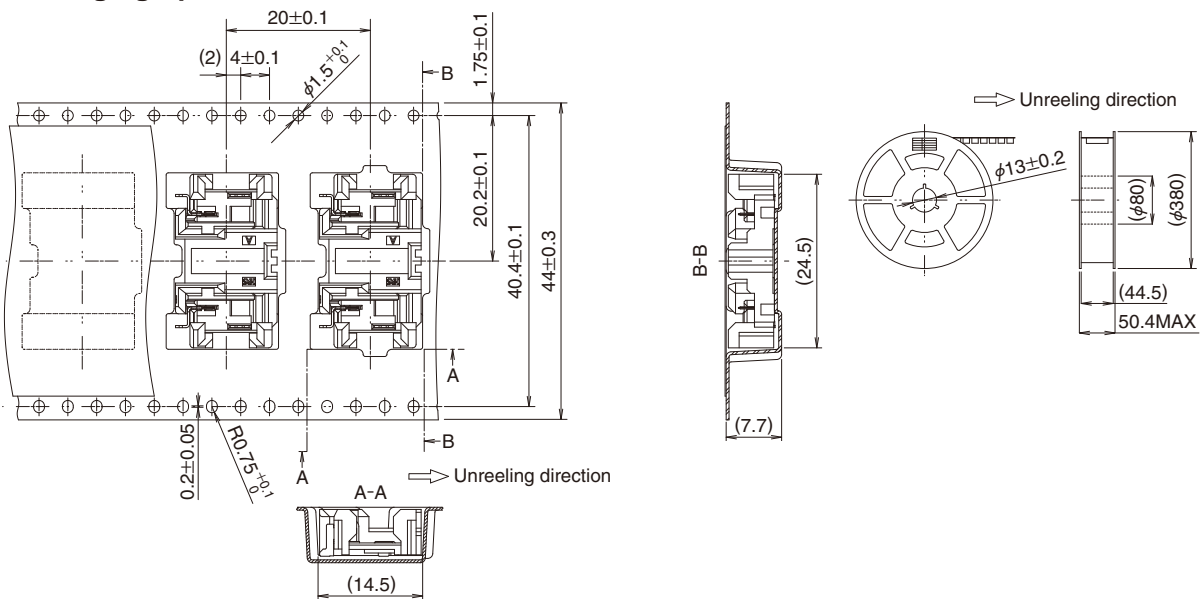

Part No.	HRS No.	No. of contacts	Insulator Color	Packaging
MDF51SU-2P-13V(23)	547-2016-6 23	2	Beige	600 pcs/reel

Please place orders in full reel increments.

■ Header (Contact pitch : 13 mm)

● Straight, through-hole

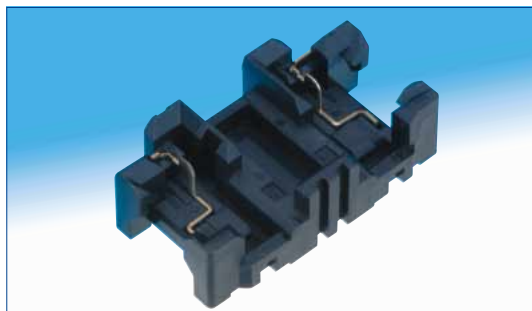

◆ Recommended PCB layout dimensions
PCB thickness : 1.6mm

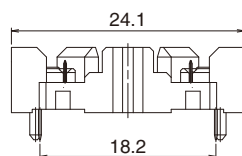
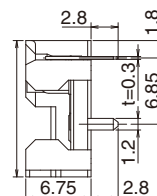
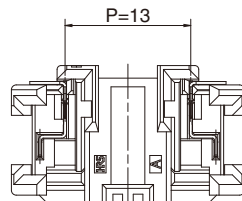
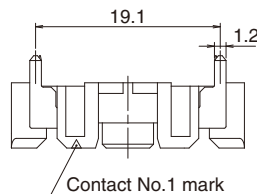
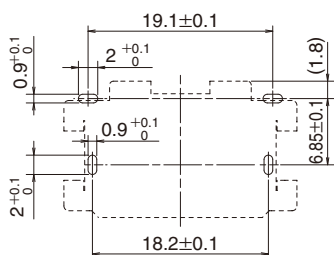

Unit : mm

● Packaging Specification

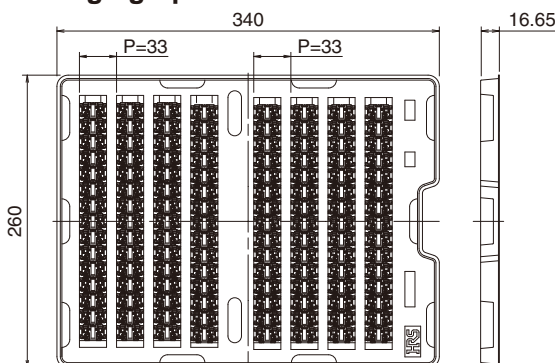

Part No.	HRS No.	No. of contacts	Insulator Color	Packaging
MDF51SY-2P-13DSA(21)	547-0920-3 21	2	Black	120 pcs/tray

Please place orders in full tray increments.

■ Crimp socket (Contact pitch : 13 mm)

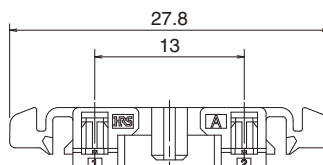
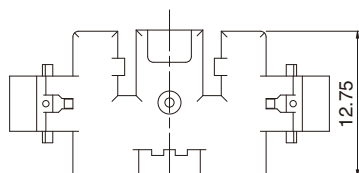
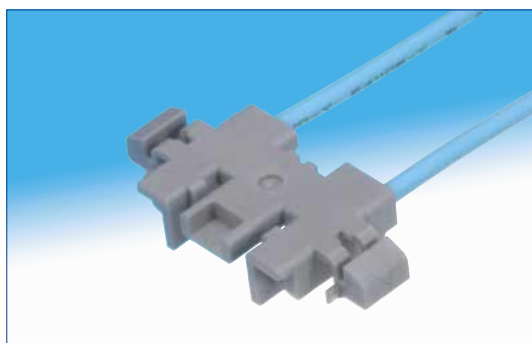

Contact No.1 indicator

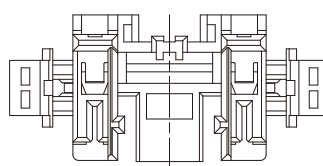
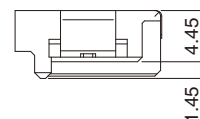

Unit : mm

Part No.	HRS No.	No. of contacts	Insulator Color	Packaging
MDF51SU-2S-13C(03)	547-2018-1 03	2	Gray	100 pcs/pack

Please place orders in full pack increments.

◆ Crimp contact

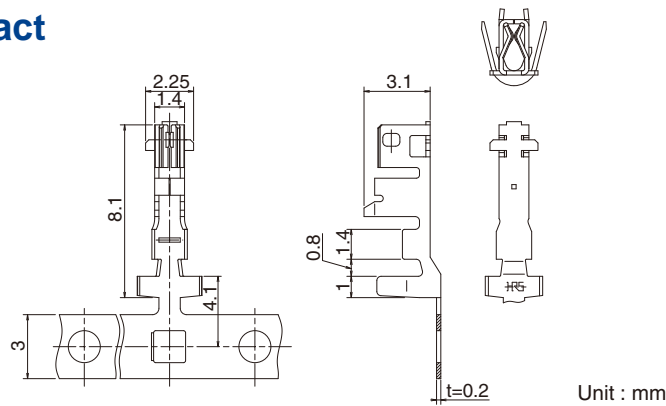

Unit : mm

Part No.	HRS No.	Packaging	Finish
MDF51-24SCF(40)	547-2005-0 40	10,000 / reel	Tin plating

Please place orders in full reel increments.

● Applicable wire (Tin plated, annealed copper wire)

Wire size (Stranded wire conductor)	Jacket diameter
AWG#24 (19 / ϕ 0.127mm)	ϕ 1.74mm

● UL style : UL3239

● Strip length
1.8 to 2.6mm

Note : When using other than the recommended wire, contact your nearest Hirose sales representative.

◆ Tools

Type	Part No.	HRS No.	Applicable contact
Applicator	AP105-MDF51-24S	901-4607-9 00	MDF51-24SCF
Press	CM-105	901-0005-4 00	_____
Contact extraction tool	DF-C-PO (B)	550-0179-2 00	MDF51-24SCF

◆ Usage Recommendations

1. Recommended temperature profile	<p>Note 1 : Up to 2 cycles of Reflow soldering are possible under the same conditions, provided that there is a return to normal temperature between the first and second cycle.</p> <p>Note 2 : The temperature profile indicates the board surface temperature at the point of contact with the connector terminals.</p>
2. Recommended flow temperature	Peak temperature : 260°C for 10 seconds max.
3. Recommended manual soldering	Manual soldering : 350°C for 3 seconds max.
4. Recommended screen thickness and open area ratio (Pattern area ratio)	Thickness : 0.15mm Open area ratio : 100%
5. Board warpage	Maximum of 0.03mm at the connector center, with both ends of the connector as reference points.
6. Cleaning conditions	Refer to "Board to cable connectors Use Handbook".
7. Wire preparation and contact crimping	Refer to "Board to cable connectors Use Handbook". The crimp contact termination must be performed using specified tools. All dimensions and crimp conditions are listed in applicable Crimp Condition Table and Crimping Quality Standards Manual.

8. Precautions

■ Mating

- ① Socket will self-align in the header.
- ② Align the Socket over the header and firmly push-down at the “O” symbol until both locks are fully engaged.
Tactile “click” sensation will confirm fully locked condition.

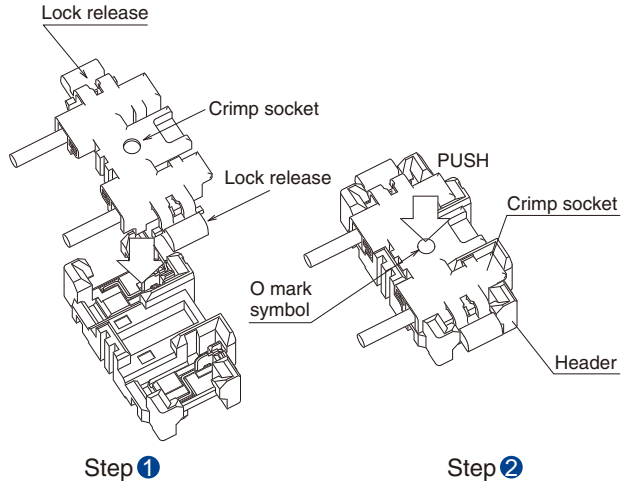

■ Unmating

- ① Compress both locks evenly, toward each other.
- ② While compressing the lock releases pull the socket straight up until free of the header.

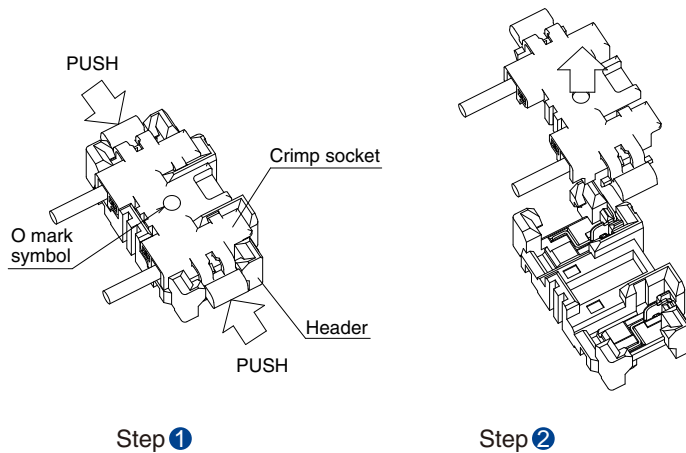

- The crimped contacts must be fully inserted in the crimp socket horizontally and will self-guide itself in the proper position
- The header must be mounted on the PC board when mating with the corresponding socket.
- Differences in colors shade of the molded components will not affect form, fit or function.
- Contact HRS if additional information is required.

MEMO :

A series of horizontal dashed lines for writing a memo.

USA:

HIROSE ELECTRIC (U.S.A.), INC. HEADQUARTERS
2688 Westhills Court, Simi Valley, CA 93065-6235
Phone : +1-805-522-7958
Fax : +1-805-522-3217
<http://www.hirose.com/us/>

USA:

HIROSE ELECTRIC (U.S.A.), INC. DETROIT OFFICE (AUTOMOTIVE)
17197 N. Laurel Park Drive, Suite 253, Livonia, MI 48152
Phone : +1-734-542-9963
Fax : +1-734-542-9964
<http://www.hirose.com/us/>

GERMANY:

HIROSE ELECTRIC EUROPE B.V. NUERNBERG OFFICE
Muggenhofer Str. 136 90429 Nuernberg
Phone : +49-911 32 68 89 63
Fax : +49-911 32 68 89 69
<http://www.hirose.com/eu/>

UNITED KINGDOM:

HIROSE ELECTRIC EUROPE BV (UK BRANCH)
4 Newton Court, Kelvin Drive, Knowlhill, Milton Keynes, MK5 8NH
Phone : +44-1908 202050
Fax : +44-1908 202058
<http://www.hirose.com/eu/>

CHINA:

HIROSE ELECTRIC TECHNOLOGIES (SHENZHEN) CO., LTD.
Room 09-13, 19/F, Office Tower Shun Hing Square, Di Wang Commercial Centre, 5002 Shen Nan Dong Road, Shenzhen City, Guangdong Province, 518008
Phone : +86-755-8207-0851
Fax : +86-755-8207-0873
<http://www.hirose.com/cn/>

KOREA:

HIROSE KOREA CO., LTD.
250, Huimanggongwon-ro, Siheung-si, Gyeonggi-do, Korea, 429-849
Phone : +82-31-496-7000,7124
Fax : +82-31-496-7100
<http://www.hirose.co.kr/>

INDIA:

HIROSE ELECTRIC SINGAPORE PTE. LTD. BANGALORE LIAISON OFFICE
Unit No-403, 4th Floor, No-84, Barton Centre, Mahatma Gandhi (MG) Road, Bangalore 560 001, Karnataka, India
Phone : +91-80-4120 1907
Fax : +91-80-4120 9908
<http://www.hirose.com/sg/>

USA:

HIROSE ELECTRIC (U.S.A.), INC. SAN JOSE OFFICE
3255 Scott Boulevard, Building 7, Suite 101 Santa Clara, CA 95054
Phone : +1-408-253-9640
Fax : +1-408-253-9641
<http://www.hirose.com/us/>

THE NETHERLANDS:

HIROSE ELECTRIC EUROPE B.V.
Hogehillweg #8 1101 CC Amsterdam Z-0
Phone : +31-20-6557460
Fax : +31-20-6557469
<http://www.hirose.com/eu/>

GERMANY:

HIROSE ELECTRIC EUROPE B.V. HANOVER OFFICE
Bayernstr. 3, Haus C 30855 Langenhagen, Germany
Phone : +49-511 97 82 61 30
Fax : +49-511 97 82 61 35
<http://www.hirose.com/eu/>

CHINA:

HIROSE ELECTRIC (SHANGHAI) CO., LTD.
1601, Henderson Metropolitan, NO.300, East Nanjing Road, Huangpu District, Shanghai, China 200001
Phone : +86-21-6391-3355
Fax : +86-21-6391-3335
<http://www.hirose.com/cn/>

HONG KONG:

HIROSE ELECTRIC HONGKONG TRADING CO., LTD.
Room 1001, West Wing, Tsim Sha Tsui Centre, 66 Mody Road, Tsim Sha Tsui East, Kowloon, Hong Kong
Phone : +852-2803-5338
Fax : +852-2591-6560
<http://www.hirose.com/hk/>

SINGAPORE:

HIROSE ELECTRIC SINGAPORE PTE. LTD.
10 Anson Road #26-16, International Plaza 079903, Singapore
Phone : +65-6324-6113
Fax : +65-6324-6123
<http://www.hirose.com/sg/>

MALAYSIA:

HIROSE ELECTRIC SINGAPORE PTE. LTD.
1-10-07, Suntech @ Penang Cybercity (1164), Lintang Mayang Pasir 3, 11950, Bayan Baru, Penang, Malaysia.
Phone : +604-619-2564
Fax : +604-619-2574
<http://www.hirose.com/sg/>

USA:

HIROSE ELECTRIC (U.S.A.), INC. CHICAGO OFFICE
580 Waters Edge Lane, Suite 205 Lombard IL 60148
Phone : +1-630-282-6701
Mail : inquiries@hirose.com
<http://www.hirose.com/us/>

GERMANY:

HIROSE ELECTRIC EUROPE B.V. GERMAN BRANCH
Herzog-Carl-Strasse 4 D-73760 Ostfildern (Scharnhäuser Park)
Phone : +49-711-4560-02-1
Fax : +49-711-4560-02-299
<http://www.hirose.com/eu/>

FRANCE:

HIROSE ELECTRIC EUROPE B.V. PARIS OFFICE
Regus La Garenne Colombes, Place de La Belgique, 71 Boulevard National La Garenne Colombes, 92250, France
Phone : +33 (0) 1 7082 3170
Fax : +33 (1) 7082 3101
<http://www.hirose.com/eu/>

CHINA:

HIROSE ELECTRIC (SHANGHAI) CO., LTD. BEIJING BRANCH
A1001, Ocean International Center, Building 56# East 4th Ring Middle Road, ChaoYang District, Beijing, 100025
Phone : +86-10-5165-9332
Fax : +86-10-5908-1381
<http://www.hirose.com/cn/>

TAIWAN:

HIROSE ELECTRIC TAIWAN CO., LTD.
103 8F, No.87, Zhengzhou Rd., Taipei
Phone : +886-2-2555-7377
Fax : +886-2-2555-7350
<http://www.hirose.com/tw/>

INDIA:

HIROSE ELECTRIC SINGAPORE PTE. LTD. DELHI LIAISON OFFICE
Office NO.519, Regus-Green Boulevard, Level5, Tower C, Sec62, Plot B-9A, Block B, Noida, 201301, Uttar Pradesh, India
Phone : +91-12-660-8018
Fax : +91-120-4804949
<http://www.hirose.com/sg/>

THAILAND:

HIROSE ELECTRIC SINGAPORE PTE. LTD. BANGKOK OFFICE (REPRESENTATIVE OFFICE)
Unit 4703, 47th FL., 1 Empire Tower, South Sathorn Road, Yannawa, Sathorn, Bangkok 10120 Thailand
Phone : +66-2-686-1255
Fax : +66-2-686-3433
<http://www.hirose.com/sg/>

**HIROSE ELECTRIC CO.,LTD.**

2-6-3, Nakagawa Chuoh, Tsuzuki-Ku, Yokohama-Shi 224-8540, JAPAN
TEL: +81-45-620-3526 Fax: +81-45-591-3726
<http://www.hirose.com>
<http://www.hirose-connectors.com>