

LM321 LOW POWER SINGLE OP AMP

FEATURES

- ($V_{CC} = 5V$, $T_A = 25^{\circ}C$. Typical values unless specified.)
- Gain-Bandwidth Product 1MHz
- Low Supply Current 430 μ A
- Low Input Bias Current 45nA
- Wide Supply Voltage Range +3V to +32V
- Stable With High Capacitive Loads
- Single Version of LM324

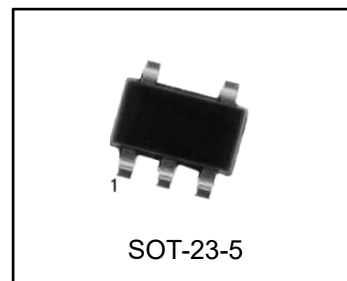

ORDERING INFORMATION

DEVICE	Package Type	MARKING	Packing	Packing Qty
LM321IDBVRG	SOT-23-5	M321	REEL	3000pcs/reel
LM321AIDBVRG	SOT-23-5	321A	REEL	3000pcs/reel

DESCRIPTION

The LM321 brings performance and economy to low power systems. With a high unity gain frequency and a specified 0.4V/ μ s slew rate, the quiescent current is only 430 μ A/amplifier (5V). The input common mode range includes ground and therefore the device is able to operate in single supply applications as well as in dual supply applications. It is also capable of comfortably driving large capacitive loads.

The LM321 is available in the SOT23-3 package.

Overall the LM321 is a low power, wide supply range performance op amp that can be designed into a wide range of applications at an economical price without sacrificing valuable board space.

APPLICATIONS

- Chargers
- Power Supplies
- Industrial: Controls, Instruments
- Desktops
- Communications Infrastructure

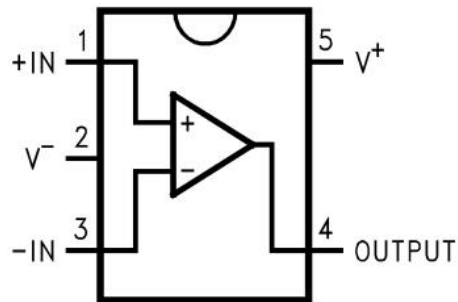
CONNECTION DIAGRAM
SOT-23-5

APPLICATION CIRCUIT

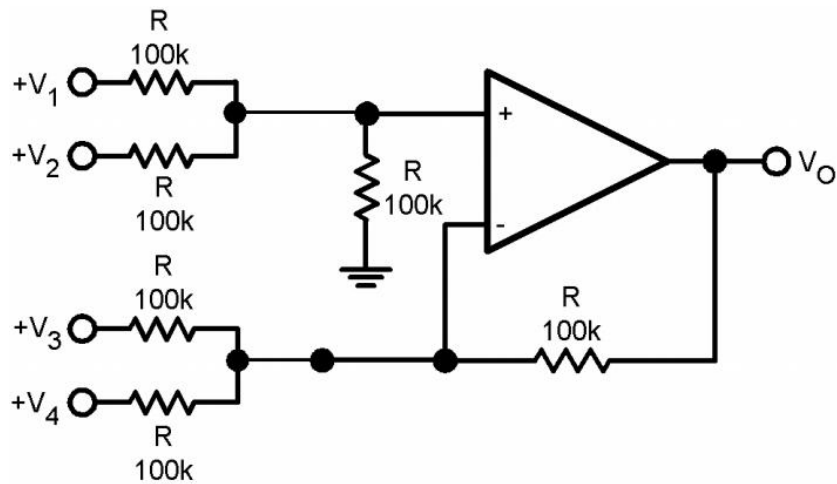
DC Summing Amplifier

 $(V_{IN}'s \geq 0 V_{DC} \text{ and } V_O \geq V_{DC})$

Where: $V_O = V_1 + V_2 - V_3 - V_4$, $(V_1 + V_2) \geq (V_3 + V_4)$ to keep $V_O > 0 V_{DC}$

ABSOLUTE MAXIMUM RATINGS ⁽¹⁾

Differential Input Voltage	±Supply Voltage
Input Current ($V_{IN} < -0.3V$) ⁽²⁾	50mA
Supply Voltage ($V^+ - V^-$)	32V
Input Voltage	-0.3V to +32V
Output Short Circuit to GND, $V^+ \leq 15V$ and $T_A = 25^\circ C$ ⁽³⁾	Continuous
Storage Temperature Range	-65°C to 150°C
Junction Temperature ⁽⁴⁾	150°C
Mounting Temperature	
Lead Temp (Soldering, 10 sec)	245°C
Infrared (10 sec)	215°C
Thermal Resistance to Ambient (θ_{JA})	265°C/W
ESD Tolerance ⁽⁵⁾	300V

1. Absolute Maximum Ratings indicate limits beyond which damage to the device may occur. Operating Ratings indicate conditions for which the device is intended to be functional, but specific performance is not ensured. For ensured specifications and the test conditions, see the Electrical Characteristics.
2. This input current will only exist when the voltage at any of the input leads is driven negative. It is due to the collector base junction of the input PNP transistors becoming forward biased and thereby acting as input diode clamps. In addition to this diode action, there is also lateral NPN parasitic transistor action on the IC chip. This transistor action can cause the output voltages of the op amps to go to the V^+ voltage level (or to ground for a large overdrive) for the time duration that an input is driven negative. This is not destructive and normal output states will re-establish when the input voltage, which was negative, again returns to a value greater than -0.36V (at 25°C).
3. Short circuits from the output V^+ can cause excessive heating and eventual destruction. When considering short circuits to ground the maximum output current is approximately 40mA independent of the magnitude of V^+ . At values of supply voltage in excess of +15V, continuous short circuits can exceed the power dissipation ratings and cause eventual destruction.
4. The maximum power dissipation is a function of $T_{J(MAX)}$, θ_{JA} , and T_A . The maximum allowable power dissipation at any ambient temperature is $P_D = (T_{J(MAX)} - T_A) / \theta_{JA}$. All numbers apply for packages soldered directly onto a PC board.
5. Human Body Model, 1.5k Ω in series with 100pF.

OPERATING RATINGS ⁽¹⁾

Temperature Range	-40°C to 85°C
Supply Voltage	3V to 30V

1. Absolute Maximum Ratings indicate limits beyond which damage to the device may occur. Operating Ratings indicate conditions for which the device is intended to be functional, but specific performance is not ensured. For ensured specifications and the test conditions, see the Electrical Characteristics.

ELECTRICAL CHARACTERISTICS

Unless otherwise specified, all limits specified for at $T_A = 25^\circ\text{C}$; $V_+ = 5\text{V}$, $V_- = 0\text{V}$, $V_O = 1.4\text{V}$. **Boldface** limits apply at temperature extremes.

Symbol	Parameter	Conditions	Min (1)	Typ (2)	Max (1)	Units
V _{OS}	Input Offset Voltage	LM321A ⁽³⁾		3	5	mV
		LM321		5	7 9	
I _{OS}	Input Offset Current			5	50 150	nA
I _B	Input Bias Current ⁽⁴⁾			45	250 500	nA
V _{CM}	Input Common-Mode Voltage Range	$V_+ = 30\text{V}$ ⁽⁵⁾ For CMRR > = 50dB	0		$V_+ - 1.5$ $V_+ - 2$	V
A _v	Large Signal Voltage Gain	$(V_+ = 15\text{V}, R_L = 2\text{k}\Omega$ $V_O = 1.4\text{V to } 11.4\text{V})$	25 15	100		V/mV
PSRR	Power Supply Rejection Ratio	$R_S \leq 10\text{k}\Omega$, $V_+ \leq 5\text{V to } 30\text{V}$	65	100		dB
CMRR	Common Mode Rejection Ratio	$R_S \leq 10\text{k}\Omega$	65	85		dB
V _O	Output Swing	V _{OH}	$V_+ = 30\text{V}, R_L = 2\text{k}\Omega$	26		V
			$V_+ = 30\text{V}, R_L = 10\text{k}\Omega$	27	28	
		V _{OL}	$V_+ = 5\text{V}, R_L = 10\text{k}\Omega$		5	20
I _S	Supply Current, No Load	$V_+ = 5\text{V}$		0.430 0.7	1.15 1.2	mA
		$V_+ = 30\text{V}$		0.660 1.5	2.85 3	
I _{SOURCE}	Output Current Sourcing	$V_{ID} = +1\text{V}, V_+ = 15\text{V}$, $V_O = 2\text{V}$	20 10	40 20		mA
I _{SINK}	Output Current Sinking	$V_{ID} = -1\text{V}$ $V_+ = 15\text{V}, V_O = 2\text{V}$	10 5	20 8		mA
		$V_{ID} = -1\text{V}$ $V_+ = 15\text{V}, V_O = 0.2\text{V}$	12	100		μA
I _O	Output Short Circuit to Ground ⁽⁶⁾	$V_+ = 15\text{V}$		40	85	mA
SR	Slew Rate	$V_+ = 15\text{V}, R_L = 2\text{k}\Omega$, $V_{IN} = 0.5 \text{ to } 3\text{V}$ $C_L = 100\text{pF}$, Unity Gain		0.4		V/ μs
GBW	Gain Bandwidth Product	$V_+ = 30\text{V}, f = 100\text{kHz}$, $V_{IN} = 10\text{mV}, R_L = 2\text{k}\Omega$, $C_L = 100\text{pF}$		1		MHz
ϕ_m	Phase Margin			60		deg
THD	Total Harmonic Distortion	$f = 1\text{kHz}, A_v = 20\text{dB}$ $R_L = 2\text{k}\Omega, V_O = 2V_{PP}$, $C_L = 100\text{pF}, V_+ = 30\text{V}$		0.015		%
e _n	Equivalent Input Noise Voltage	$f = 1\text{kHz}, R_S = 100\Omega$ $V_+ = 30\text{V}$		40		$\text{nV}\sqrt{\text{Hz}}$

(1) All limits are specified by testing or statistical analysis.

(2) Typical values represent the most likely parametric norm.

(3) $V_O = 1.4\text{V}$, $R_S = 0\Omega$ with V_+ from 5V to 30V; and over the full input common-mode range (0V to $V_+ - 1.5\text{V}$) at 25°C .

(4) The direction of the input current is out of the IC due to the PNP input stage. This current is essentially constant, independent of the state of the output so no loading change exists on the input lines.

(5) The input common-mode voltage of either input signal voltage should not be allowed to go negative by more than 0.3V (at 25°C). The upper end of the common-mode voltage range is $V_+ - 1.5\text{V}$ at 25°C , but either or both inputs can go to +32V without damage, independent of the magnitude of V_+ .

(6) Short circuits from the output V_+ can cause excessive heating and eventual destruction. When considering short circuits to ground the maximum output current is approximately 40mA independent of the magnitude of V_+ . At values of supply voltage in excess of +15V, continuous short circuits can exceed the power dissipation ratings and cause eventual destruction.

SIMPLIFIED SCHEMATIC

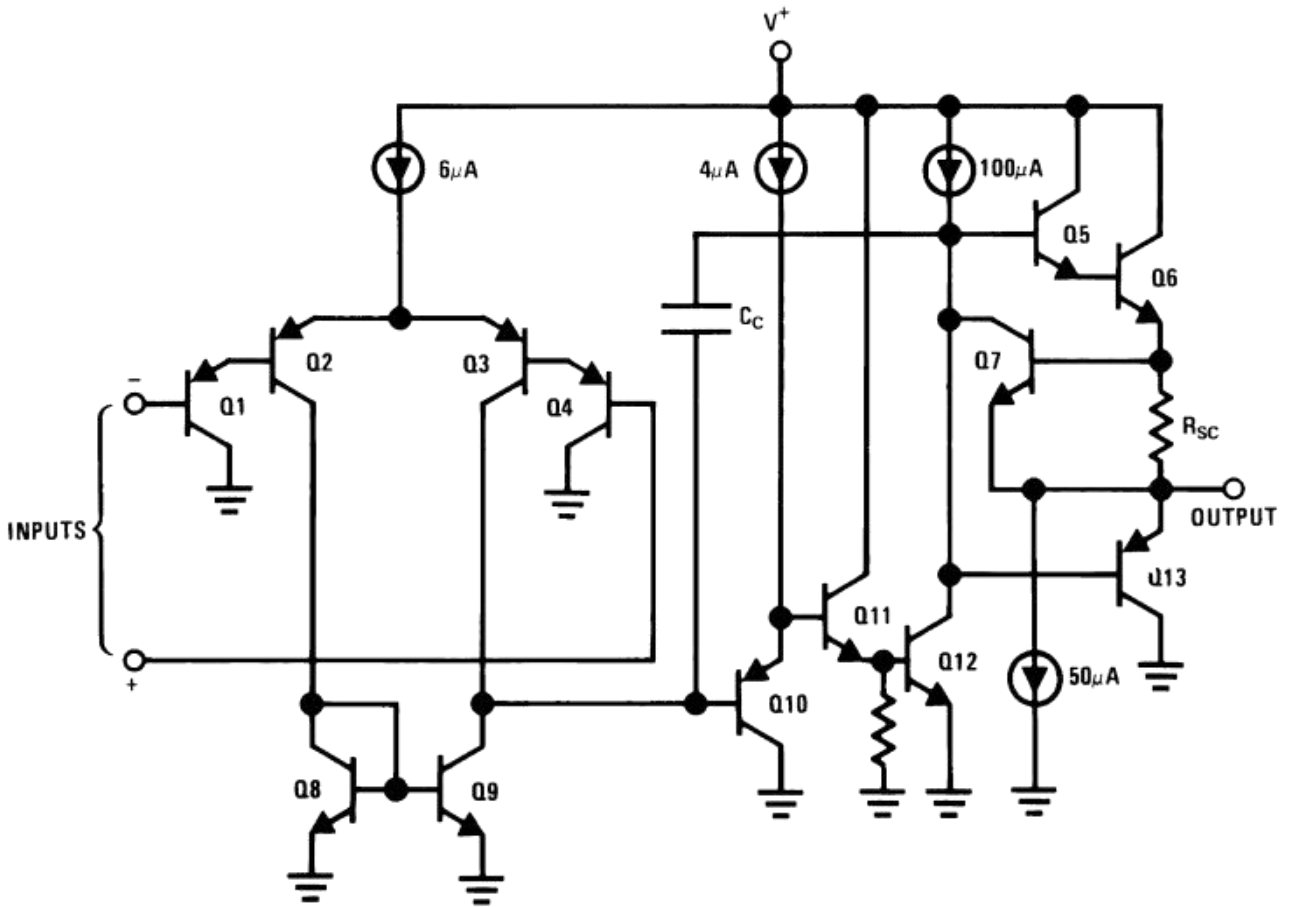

TYPICAL PERFORMANCE CHARACTERISTICS

Unless otherwise specified, $V_S = +5V$, single supply, $T_A = 25^\circ C$.

Small Signal Pulse Response

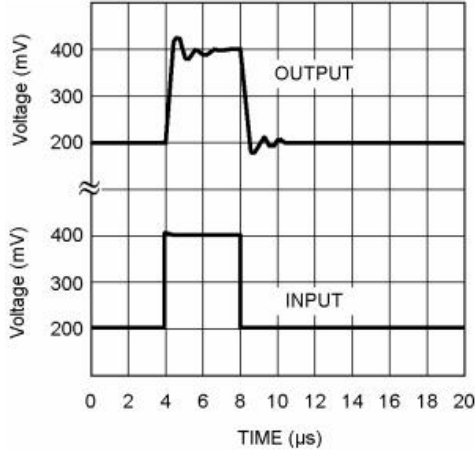

Large Signal Pulse Response

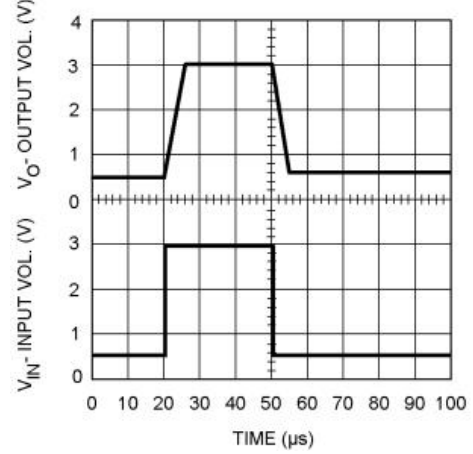

Supply Current vs. Supply Voltage

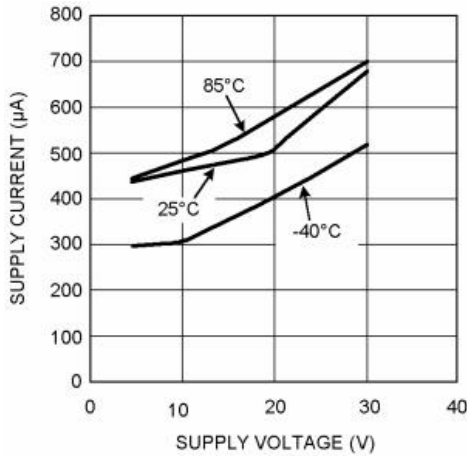

Sinking Current vs. Output Voltage

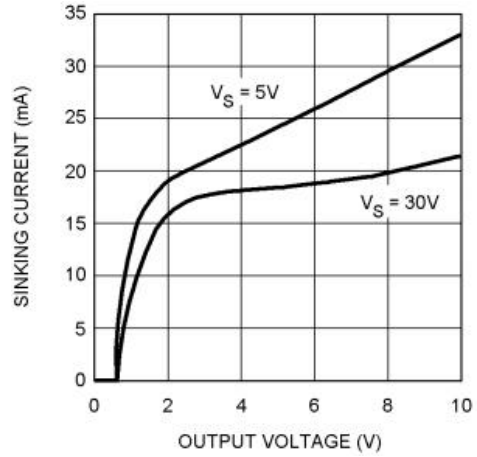

Source Current vs. Output Voltage

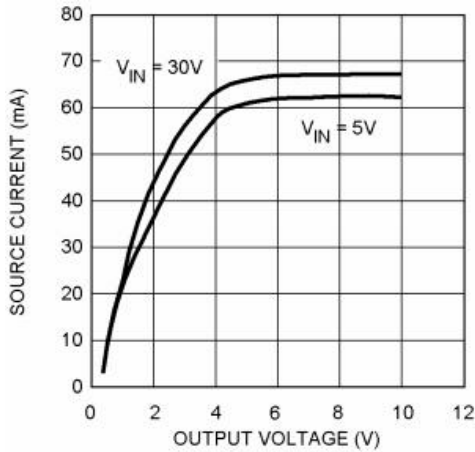

Open Loop Frequency Response

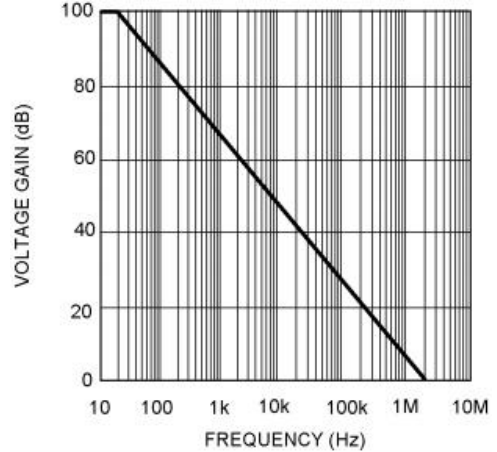

APPLICATION HINTS

The LM321 op amp can operate with a single or dual power supply voltage, has true-differential inputs, and remain in the linear mode with an input common-mode voltage of 0 VDC. This amplifier operates over a wide range of power supply voltages, with little change in performance characteristics. At 25°C amplifier operation is possible down to a minimum supply voltage of 3V.

Large differential input voltages can be easily accommodated and, as input differential voltage protection diodes are not needed, no large input currents result from large differential input voltages. The differential input voltage may be larger than V^+ without damaging the device. Protection should be provided to prevent the input voltages from going negative more than $-0.3 V_{DC}$ (at 25°C). An input clamp diode with a resistor to the IC input terminal can be used.

To reduce the power supply drain, the amplifier has a class A output stage for small signal levels which converts to class B in a large signal mode. This allows the amplifiers to both source and sink large output currents.

Therefore both NPN and PNP external current boost transistors can be used to extend the power capability of the basic amplifiers. The output voltage needs to raise approximately 1 diode drop above ground to bias the onchip vertical PNP transistor for output current sinking applications.

For AC applications, where the load is capacitively coupled to the output of the amplifier, a resistor should be used, from the output of the amplifier to ground to increase the class A bias current and to reduce distortion.

Capacitive loads which are applied directly to the output of the amplifier reduce the loop stability margin. Values of 50pF can be accommodated using the worst-case non-inverting unity gain connection. Large closed loop gains or resistive isolation should be used if large load capacitance must be driven by the amplifier.

The bias network of the LM321 establishes a supply current which is independent of the magnitude of the power supply voltage over the range of from $3 V_{DC}$ to $30 V_{DC}$.

Output short circuits either to ground or to the positive power supply should be of short time duration. Units can be destroyed, not as a result of the short circuit current causing metal fusing, but rather due to the large increase in IC chip dissipation which will cause eventual failure due to excessive junction temperatures. The larger value of output source current which is available at 25°C provides a larger output current capability at elevated temperatures than a standard IC op amp.

The circuits presented in the section on typical applications emphasize operation on only a single power supply voltage. If complementary power supplies are available, all of the standard op amp circuits can be used. In general, introducing a pseudo-ground (a bias voltage reference of $V^+ / 2$) will allow operation above and below this value in single power supply systems. Many application circuits are shown which take advantage of the wide input common-mode voltage range which includes ground. In most cases, input biasing is not required and input voltages which range to ground can easily be accommodated.

TYPICAL APPLICATIONS

Non-Inverting DC Gain (0V Input = 0V Output)

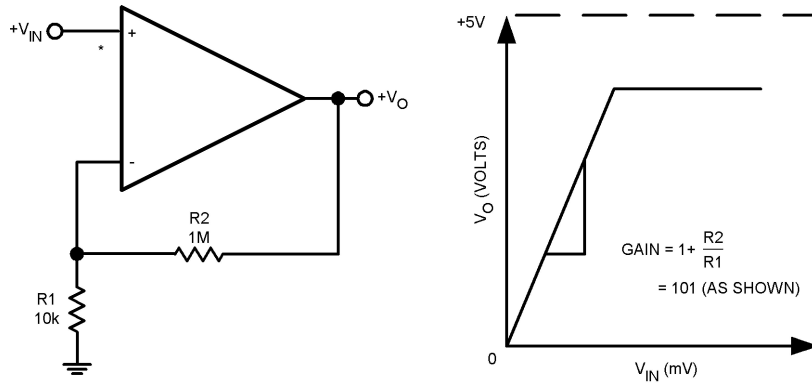

* R NOT NEEDED DUE TO TEMPERATURE INDEPENDENT I_{IN}

Amplitude Modulator Circuit

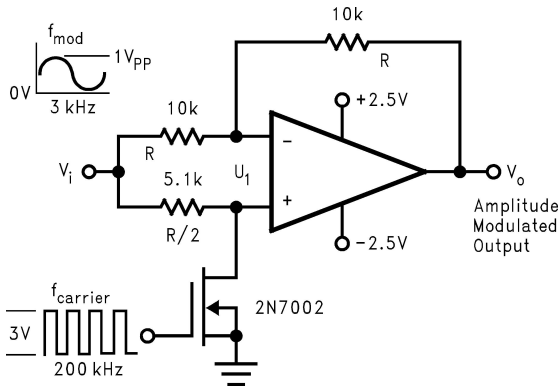

DC Summing Amplifier (V)

(I_N 's ≥ 0 V_{DC} and $V_O \geq V_{DC}$)

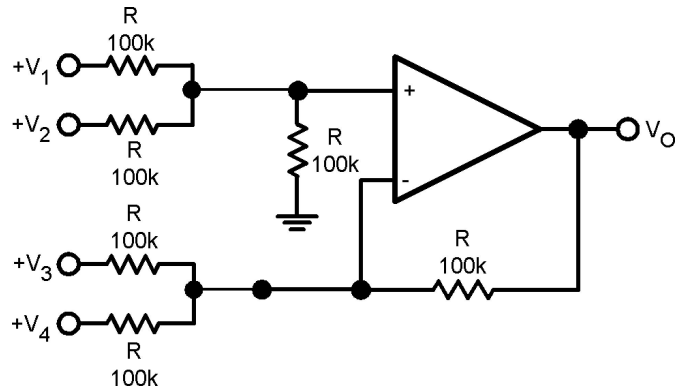

Where: $V_O = V_1 + V_2 - V_3 - V_4$, ($V_1 + V_2$) \geq ($V_3 + V_4$) to keep $V_O > 0$ V_{DC}

Power Amplifier

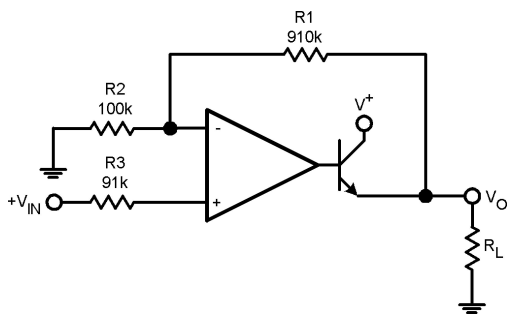

$V_O = 0$ V_{DC} for $V_{IN} = 0$ V_{DC} , $A_v = 10$

LED Driver

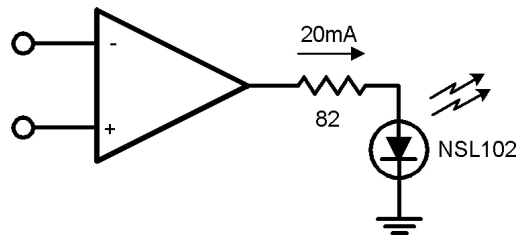

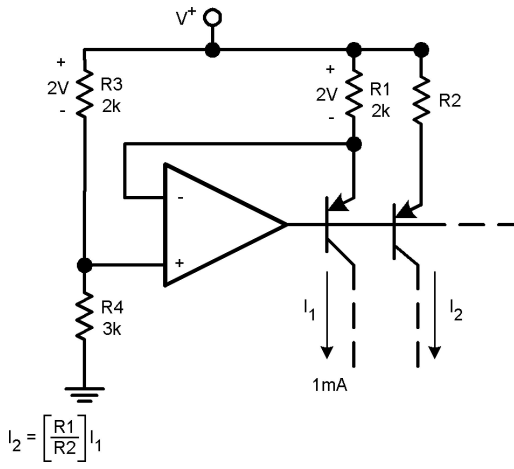
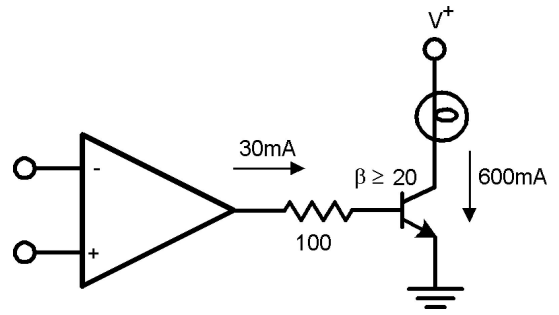
Fixed Current Sources

Lamp Driver

PHYSICAL DIMENSIONS

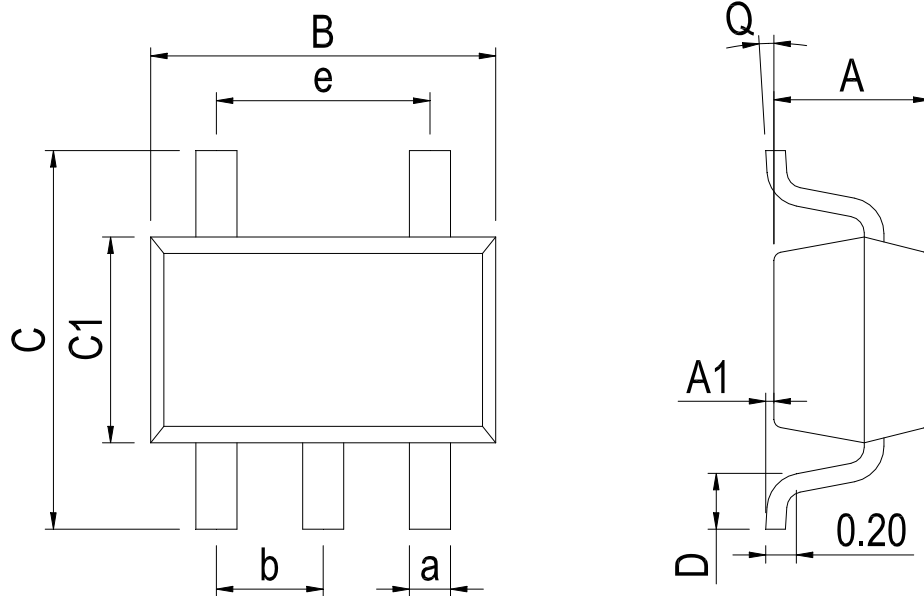
SOT-23-5

Dimensions In Millimeters(SOT-23-5)

Symbol:	A	A1	B	C	C1	D	Q	a	b	e
Min:	1.00	0.00	2.82	2.65	1.50	0.30	0°	0.30	0.95 BSC	1.90 BSC
Max:	1.15	0.15	3.02	2.95	1.70	0.60	8°	0.50		

REVISION HISTORY

DATE	REVISION	PAGE
2014-3-14	New	1-12
2023-7-24	Update encapsulation type、 Update Lead Temperature	1、 3
2024-11-12	Update SOT-23-5 Physical dimension	10

IMPORTANT STATEMENT:

Hanschip Semiconductor reserves the right to change its products and services without notice. Before ordering, the customer shall obtain the latest relevant information and verify whether the information is up to date and complete. Hanschip Semiconductor does not assume any responsibility or obligation for the altered documents.

Customers are responsible for complying with safety standards and taking safety measures when using Hanschip Semiconductor products for system design and machine manufacturing. You will bear all the following responsibilities: select the appropriate Hanschip Semiconductor products for your application; Design, validate and test your application; Ensure that your application meets the appropriate standards and any other safety, security or other requirements. To avoid the occurrence of potential risks that may lead to personal injury or property loss.

Hanschip Semiconductor products have not been approved for applications in life support, military, aerospace and other fields, and Hanschip Semiconductor will not bear the consequences caused by the application of products in these fields. All problems, responsibilities and losses arising from the user's use beyond the applicable area of the product shall be borne by the user and have nothing to do with Hanschip Semiconductor, and the user shall not claim any compensation liability against Hanschip Semiconductor by the terms of this Agreement.

The technical and reliability data (including data sheets), design resources (including reference designs), application or other design suggestions, network tools, safety information and other resources provided for the performance of semiconductor products produced by Hanschip Semiconductor are not guaranteed to be free from defects and no warranty, express or implied, is made. The use of testing and other quality control technologies is limited to the quality assurance scope of Hanschip Semiconductor. Not all parameters of each device need to be tested.

The documentation of Hanschip Semiconductor authorizes you to use these resources only for developing the application of the product described in this document. You have no right to use any other Hanschip Semiconductor intellectual property rights or any third party intellectual property rights. It is strictly forbidden to make other copies or displays of these resources. You should fully compensate Hanschip Semiconductor and its agents for any claims, damages, costs, losses and debts caused by the use of these resources. Hanschip Semiconductor accepts no liability for any loss or damage caused by infringement.