

版次	变更摘要	日期	序号	品名	材质
0	新产品发行	2015/1/28	①	0.5掀盖胶芯 (H1.5)	LCP UL94V-0 本色
			②	0.5掀盖端子 (H1.5)	铜合金/表面镀锡 镀金
			③	0.5掀盖后盖 (H1.5)	LCP UL94V-0 黑色
			④	0.5掀盖焊片 (H1.5)	铜合金/表面镀锡

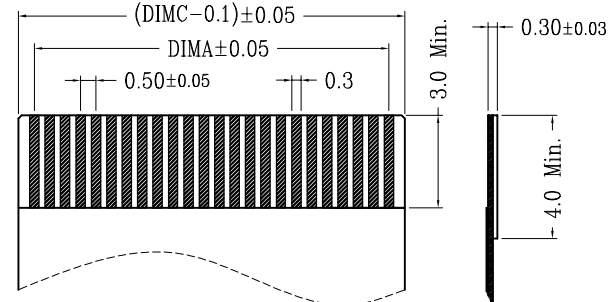

适用扁平线 (Applicable Flat Cable)

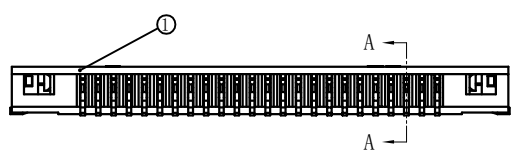
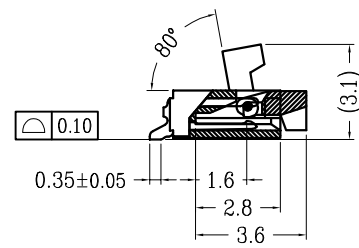
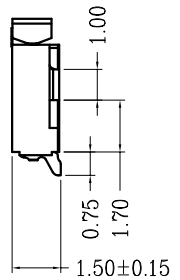
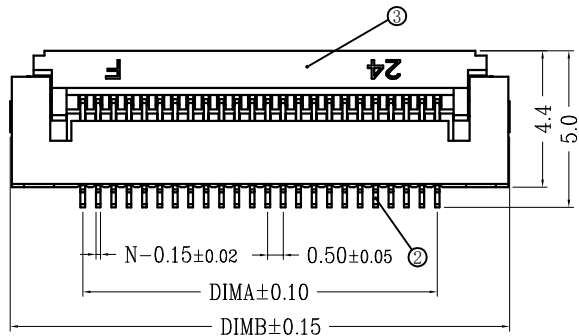
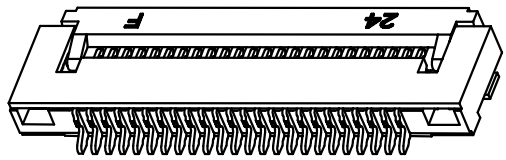
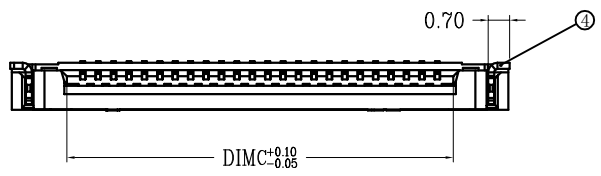
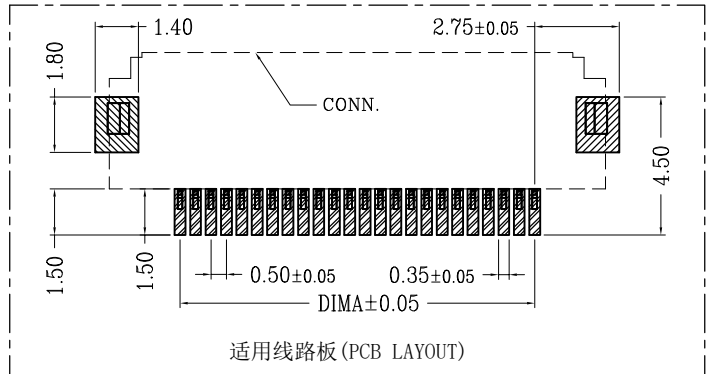

适用线路板 (PCB LAYOUT)

CKT	DIMA	DIMB	DIMC	CKT	DIMA	DIMB	DIMC
4	1.50	6.20	2.53	33	16.00	20.70	17.03
5	2.00	6.70	3.03	34	16.50	21.20	17.53
6	2.50	7.20	3.53	35	17.00	21.70	18.03
7	3.00	7.70	4.03	36	17.50	22.20	18.53
8	3.50	8.20	4.53	37	18.00	22.70	19.03
9	4.00	8.70	5.03	38	18.50	23.20	19.53
10	4.50	9.20	5.53	39	19.00	23.70	20.03
11	5.00	9.70	6.03	40	19.50	24.20	20.53
12	5.50	10.20	6.53	41	20.00	24.70	21.03
13	6.00	10.70	7.03	42	20.50	25.20	21.53
14	6.50	11.20	7.53	43	21.00	25.70	22.03
15	7.00	11.70	8.03	44	21.50	26.20	22.53
16	7.50	12.20	8.53	45	22.00	26.70	23.03
17	8.00	12.70	9.03	46	22.50	27.20	23.53
18	8.50	13.20	9.53	47	23.00	27.70	24.03
19	9.00	13.70	10.03	48	23.50	28.20	24.53
20	9.50	14.20	10.53	49	24.00	28.70	25.03
21	10.00	14.70	11.03	50	24.50	29.20	25.53
22	10.50	15.20	11.53	51	25.00	29.70	26.03
23	11.00	15.70	12.03	52	25.50	30.20	26.53
24	11.50	16.20	12.53	53	26.00	30.70	27.03
25	12.00	16.70	13.03	54	26.50	31.20	27.53
26	12.50	17.20	13.53	55	27.00	31.70	28.03
27	13.00	17.70	14.03	56	27.50	32.20	28.53
28	13.50	18.20	14.53	57	28.00	32.70	29.03
29	14.00	18.70	15.03	58	28.50	33.20	29.53
30	14.50	19.20	15.53	59	29.00	33.70	30.03
31	15.00	19.70	16.03	60	29.50	34.20	30.53
32	15.50	20.20	16.53				

技术指标:

1. 塑件表面应光洁、无毛边、无明显收缩、缺陷、裂纹等现象。
2. 温度范围: -25° C~85° C.
3. 额定电压: 50V, AC/DC(等效).
4. 接触电阻: ≤0.03Ω.
5. 绝缘电阻: ≥500MΩ



一般公差 (TOLERANCE)  
 X ±0.50 XX ±1.0  
 X ±0.20 .XXX ±0.05  
 ANGLES ±1°

# 广东国连电子有限公司

品名 (TITLE)	0.5翻盖下接H1.5	制图 (DR)	
料号 (DWG.NO)	0515-nCL-SN-RW	校对 (CHKD)	
比例 (SCALE)	1:1	审核 (APPD)	
单位 (UNITS)	mm	张数 (SHEET)	1 OF 1
		SIZE	A4
		REV	A

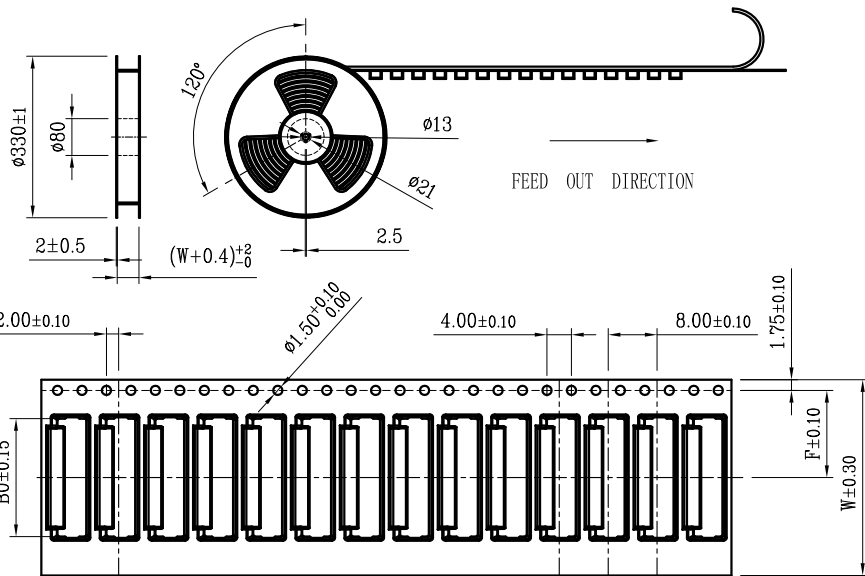
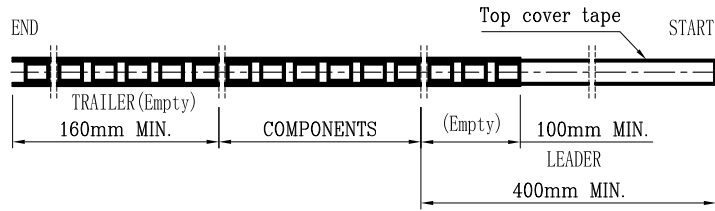

CKT (0.5mm pitch)	W	PCS/REEL	REEL/CARTON	SUM (PCS)
4	16	4000	14	56000
5		4000	14	56000
6		4000	14	56000
7		4000	14	56000
8		4000	14	56000
9		4000	14	56000
10		4000	14	56000
11		24	4000	10
12	4000		10	40000
13	4000		10	40000
14	4000		10	40000
15	4000		10	40000
16	4000		10	40000
17	4000		10	40000
18	4000		10	40000
19	4000		10	40000
20	4000		10	40000
21	4000		10	40000
22	4000		10	40000
23	4000		10	40000
24	4000		10	40000

NOTE(注):

1. 10 SPROCKET HOLE PITCH CUMULATIVE TOLERANCE  $\pm 0.2\text{mm}$ . (10片孔距累积公差 $\pm 0.2\text{mm}$ .)
2. CARRIER CAMBER NOT TO EXCEED 1mm IN 100mm. (载带拱/弧形MAX:1/100mm.)
3. ALL DIMENSIONS MEET EIA-481 REQUIREMENTS. (所有的尺寸要满足协会EIA-481规范.)
4. MATERIAL: BLACK ANTISTATIC PS. (载带材料: 黑色防静电PS.)
5. THICKNESS:  $0.30 \pm 0.05\text{mm}$ . (载带厚度:  $0.30 \pm 0.05\text{mm}$ .)
6. PACKING LENGTH PER REEL: 33 METERS. (每卷包装长度: 33米.)
7. COMPONENT LOAD PER REEL: 4000 PCS. (每卷包装数量: 4000只.)
8. 纸箱装箱以不超过装箱线为准, 空余位置用塑料泡沫及聚乙烯填充.
9. 纸箱分小、中、标准型3种规格型号: 装箱为整箱(左下包装量)采用标准型纸箱包装, 未达到整箱数量以产品量适当采用小型或中型纸箱包装.

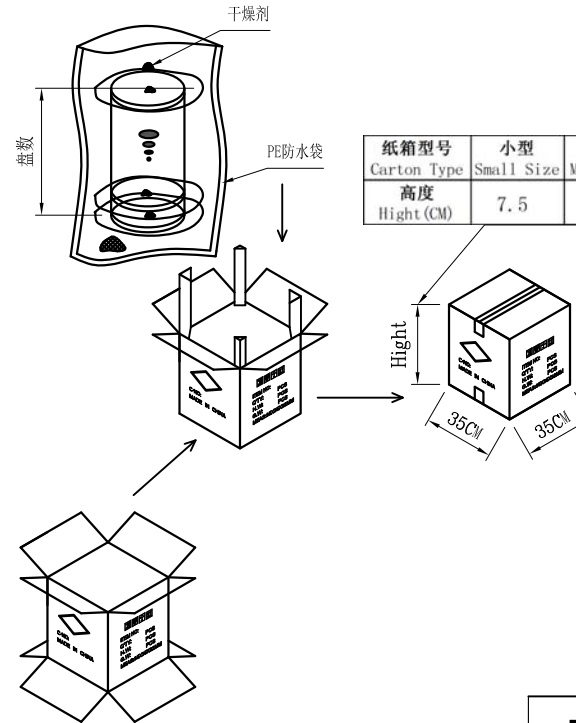

纸箱型号 Carton Type	小型 Small Size	中型 Medium	标准型 Standard
高度 Height (CM)	7.5	15	32

CKT (0.5mm pitch)	B0	W	F
4	6.30	16	7.5
5	6.80		
6	7.30		
7	7.80		
8	8.30		
9	8.80		
10	9.30		
11	9.80		
12	10.30	24	11.5
13	10.80		
14	11.30		
15	11.80		
16	12.30		
17	12.80		
18	13.30		
19	13.80		
20	14.30		
21	14.80		
22	15.30		
23	15.80		
24	16.30		

# 广东国连电子有限公司

品名 (TITLE)	0.5翻盖下接H1.5	制图 (DR)	
料号 (DWG.NO)	0515-nCL-SN	校对 (CHKD)	
比例 (SCALE)	---	审核 (APPD)	
单位 (UNITS)	mm	张数 (SHEET)	1 OF 2
		SIZE	A4
		REV	A

一般公差 (TOLERANCE)  
 X  $\pm 0.50$  XX  $\pm 15$   
 X  $\pm 0.25$  XXX  $\pm 10$   
 ANGLES  $\pm 2^\circ$

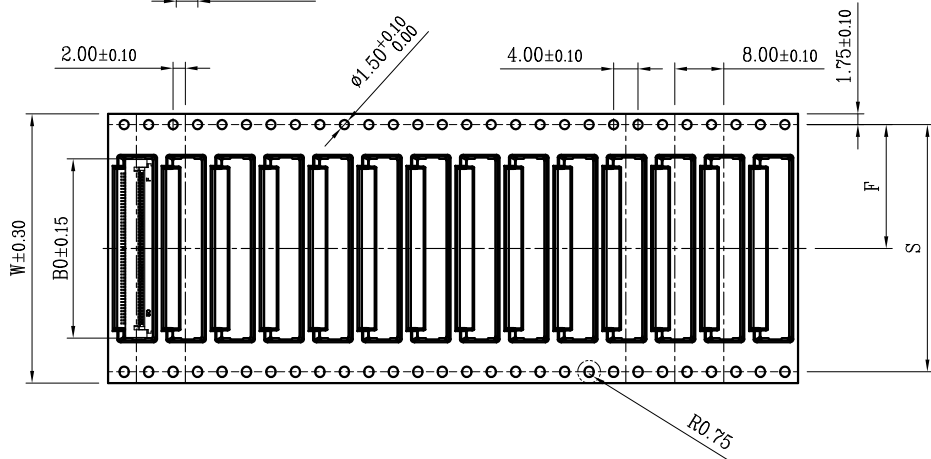
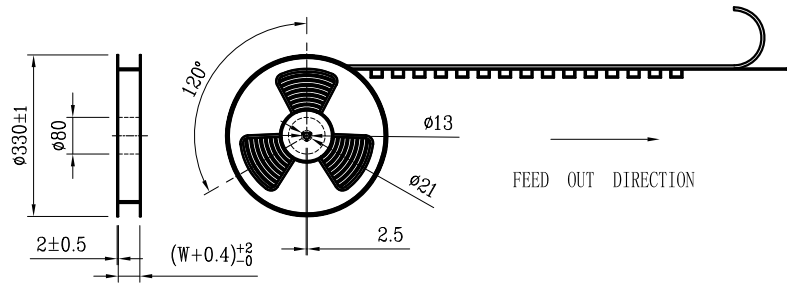
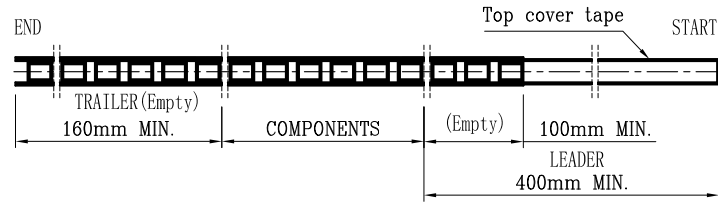

NOTE(注):

1. 10 SPROCKET HOLE PITCH CUMULATIVE TOLERANCE  $\pm 0.2\text{mm}$ . (10片孔距累积公差 $\pm 0.2\text{mm}$ .)
2. CARRIER CAMBER NOT TO EXCEED 1mm IN 100mm. (载带拱/弧形MAX:1/100mm.)
3. ALL DIMENSIONS MEET EIA-481 REQUIREMENTS. (所有的尺寸要满足协会EIA-481规范.)
4. MATERIAL: BLACK ANTISTATIC PS. (载带材料: 黑色防静电PS.)
5. THICKNESS:  $0.30 \pm 0.05\text{mm}$ . (载带厚度:  $0.30 \pm 0.05\text{mm}$ .)
6. PACKING LENGTH PER REEL: 33 METERS. (每卷包装长度: 33米.)
7. COMPONENT LOAD PER REEL: 4000 PCS. (每卷包装数量: 4000只.)
8. 纸箱装箱以不超过装箱线为准, 空余位置用塑料泡沫及聚乙烯填充.
9. 纸箱分小、中、标准型3种规格型号: 装箱为整箱(左下包装量)采用标准型纸箱包装, 未达到整箱数量以产品量适当采用小型或中型纸箱包装.

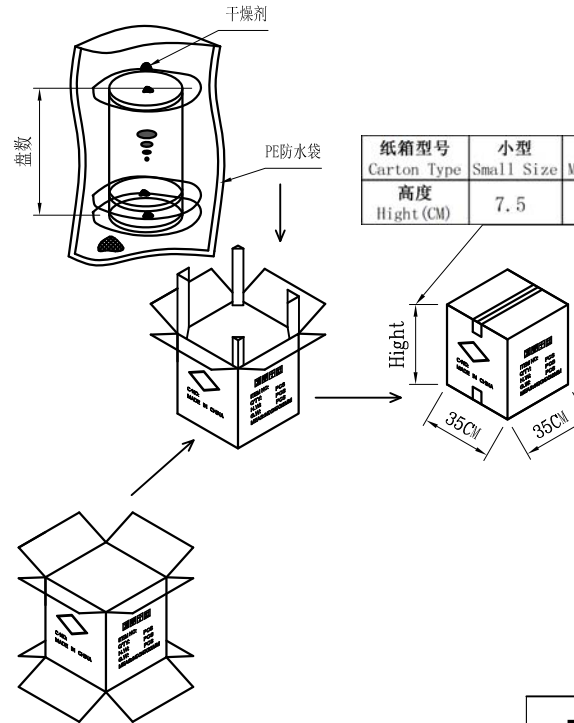

纸箱型号 Carton Type	小型 Small Size	中型 Medium	标准型 Standard
高度 Height (CM)	7.5	15	32

CKT (0.5mm pitch)	B0	W	F	S
25	16.80	32	14.2 $\pm$ 0.10	28.4
26	17.30			
27	17.80			
28	18.30			
29	18.80			
30	19.30			
31	19.80			
32	20.30			
33	20.80			
34	21.30			
35	21.80			
36	22.30			
37	22.80			
38	23.30			
39	23.80			
40	24.30			
41	24.80			
42	25.30			
43	25.80			
44	26.30			
45	26.80			
46	27.30			
47	27.80			
48	28.30			
49	28.80			
50	29.30			
51	29.80			
52	30.30			
53	30.80			
54	31.30			
55	31.80			
56	32.30			
57	32.80			
58	33.30			
59	33.80			
60	34.30			
		44	20.2 $\pm$ 0.15	40.4
		56	26.25 $\pm$ 0.15	52.4

CKT (0.5mm pitch)	W	PCS/REEL	REEL/CARTON	SUM (PCS)	CKT (0.5mm pitch)	W	PCS/REEL	REEL/CARTON	SUM (PCS)
25	32	4000	8	32000	43	44	4000	6	24000
26		4000	8	32000	44		4000	6	24000
27		4000	8	32000	45		4000	6	24000
28		4000	8	32000	46		4000	6	24000
29		4000	8	32000	47		4000	6	24000
30		4000	8	32000	48		4000	6	24000
31		4000	8	32000	49		4000	6	24000
32		4000	8	32000	50		4000	6	24000
33		4000	8	32000	51		4000	6	24000
34		4000	8	32000	52		4000	6	24000
35		4000	6	24000	53		4000	6	24000
36	4000	6	24000	54	4000	6	24000		
37	4000	6	24000	55	4000	6	24000		
38	44	4000	6	24000	56	56	4000	5	20000
39		4000	6	24000	57		4000	5	20000
40		4000	6	24000	58		4000	5	20000
41		4000	6	24000	59		4000	5	20000
42		4000	6	24000	60		4000	5	20000

# 广东国连电子有限公司

品名 (TITLE)	0.5翻盖下接H1.5		制图 (DR)
料号 (DWG.NO)	0515-nCL-SN		校对 (CHKD)
比例 (SCALE)	---	单位 (UNITS)	mm
张数 (SHEET)	2 OF 2	尺寸 (SIZE)	A4
审核 (APPD)		REV	A

一般公差 (TOLERANCE)  
 X  $\pm 0.50$  XX  $\pm 15$   
 X  $\pm 0.25$  XXX  $\pm 10$   
 ANGLES  $\pm 2^\circ$