

S1C17 Family Application Note

# **Remote Controller Reference Board Application Notes**

## Evaluation board/kit and Development tool important notice

1. This evaluation board/kit or development tool is designed for use for engineering evaluation, demonstration, or development purposes only. Do not use it for other purposes. It is not intended to meet the requirements of design for finished products.
2. This evaluation board/kit or development tool is intended for use by an electronics engineer and is not a consumer product. The user should use it properly and in a safe manner. Seiko Epson does not assume any responsibility or liability of any kind of damage and/or fire caused by the use of it. The user should cease to use it when any abnormal issue occurs even during proper and safe use.
3. The part used for this evaluation board/kit or development tool may be changed without any notice.

## NOTICE

No part of this material may be reproduced or duplicated in any form or by any means without the written permission of Seiko Epson. Seiko Epson reserves the right to make changes to this material without notice. Seiko Epson does not assume any liability of any kind arising out of any inaccuracies contained in this material or due to its application or use in any product or circuit and, further, there is no representation that this material is applicable to products requiring high level reliability, such as, medical products. Moreover, no license to any intellectual property rights is granted by implication or otherwise, and there is no representation or warranty that anything made in accordance with this material will be free from any patent or copyright infringement of a third party. When exporting the products or technology described in this material, you should comply with the applicable export control laws and regulations and follow the procedures required by such laws and regulations. You are requested not to use, to resell, to export and/or to otherwise dispose of the products (and any technical information furnished, if any) for the development and/or manufacture of weapon of mass destruction or for other military purposes.

All brands or product names mentioned herein are trademarks and/or registered trademarks of their respective companies.

# Table of Contents

<b>1. Overview</b>	<b>1</b>
<b>1.1 List of Components</b>	<b>1</b>
1.1.1 Hardware Configuration	1
1.1.2 Software and Document Configuration	2
1.1.3 Design Data Configuration	2
<b>2. Reference Board</b>	<b>3</b>
<b>2.1 Hardware Specifications</b>	<b>3</b>
<b>2.2 Name and Function of Each Part</b>	<b>5</b>
<b>2.3 Connectors and Through Holes</b>	<b>7</b>
2.3.1 ICDmini connector	7
2.3.2 UART Connector	10
2.3.3 Infrared Receiver Socket	10
2.3.4 LCD Power Supply	11
2.3.5 Through Holes	12
<b>2.4 Power Supply</b>	<b>13</b>
<b>2.5 Circuit Diagram</b>	<b>14</b>
<b>2.6 LCD Wiring Diagram</b>	<b>15</b>
<b>2.7 Parts List</b>	<b>18</b>
<b>3. System Resources</b>	<b>19</b>
<b>3.1 Microcontroller Resources</b>	<b>19</b>
<b>3.2 Functions Used</b>	<b>20</b>
<b>4. Operation Mode</b>	<b>21</b>
<b>4.1 Switching Operation Mode</b>	<b>21</b>
<b>4.2 Remote Controller Mode</b>	<b>22</b>
4.2.1 Turning Air Conditioner On or Off	22
4.2.2 Normal Operation	22
4.2.2.1 Changing Air Conditioner Operation Mode	22
4.2.2.2 Adjusting Temperature	22
4.2.2.3 Adjusting Vertical Airflow Direction	22
4.2.2.4 Adjusting Horizontal Airflow Direction	23
4.2.2.5 Adjusting Air Volume	23
4.2.2.6 Displaying Date	23
4.2.2.7 Displaying Timer Settings	23
4.2.2.8 Switching to Clock Setting Mode	23
4.2.2.9 Switching to Timer Setting Mode	23
4.2.3 Clock Settings	24

---

4.2.4	Timer Settings.....	26
<b>4.3</b>	<b>Terminal Mode .....</b>	<b>28</b>
4.3.1	Overview.....	28
4.3.2	Initialization Command (led_set).....	29
4.3.3	IR Remote Control Code Transmission Command (led_snd).....	30
4.3.4	IR Remote Control Code Reception Command (led_rcv).....	30
<b>4.4</b>	<b>Demonstration Mode.....</b>	<b>31</b>
<b>4.5</b>	<b>Test Mode.....</b>	<b>32</b>
<b>5.</b>	<b>Software Description .....</b>	<b>34</b>
<b>5.1</b>	<b>Functional Blocks .....</b>	<b>34</b>
<b>5.2</b>	<b>Operation Schematic Diagram.....</b>	<b>35</b>
<b>5.3</b>	<b>s1c17m33_remote_sample_gnu17v3.....</b>	<b>36</b>
5.3.1	File Configuration (src folder).....	36
5.3.2	File configuration (inc folder).....	37
5.3.3	Module Description.....	38
5.3.4	Sample Program Operation Overview .....	41
5.3.4.1	Function Overview .....	41
5.3.4.1.1	Air Conditioner Operation Function .....	41
5.3.4.1.2	Air Conditioner Segment LCD Display Function.....	41
5.3.4.1.3	Tact Switch (Key) Input Function.....	42
5.3.4.1.3.1	Key Scan (Acquiring Key Code).....	42
5.3.4.1.3.2	Determining Key Input State Transition (Acquiring Key Event).....	43
5.3.4.1.3.3	Acquiring Key Input State .....	44
5.3.4.1.3.4	Operation of Key Input Interface.....	45
5.3.4.1.4	IR Remote Control Code Transmission Function .....	49
5.3.4.1.4.1	IR Remote Control Code Transmission Method .....	49
5.3.4.1.4.2	Operation of IR Remote Control Code Transmission Interface.....	50
5.3.4.1.5	IR Remote Control Code Conversion Function .....	53
5.3.4.1.5.1	Example to Change Conversion Processing.....	54
5.3.4.1.5.2	Conversion/Transmission Procedure .....	54
5.3.4.1.6	Battery Level Monitor .....	56
5.3.4.1.6.1	Battery Level Detection Method .....	56
5.3.4.1.6.2	Operation of Battery Level Monitor Interface.....	56
5.3.4.2	Configuration of Application Program.....	59
5.3.4.2.1	Configuration Examples .....	59
5.3.4.3	Microcontroller Boot Processing .....	61
5.3.4.4	Processing in Remote Controller Mode.....	62
5.3.4.4.1	Key Input Processing .....	65
5.3.4.4.2	Normal Operation Mode Key Input Processing .....	66
5.3.4.4.3	Operation Mode Key Input Processing.....	67
5.3.4.4.4	Temperature Up/Down Key Input Processing .....	68
5.3.4.4.5	Vertical Airflow Direction Key Input Processing.....	69

5.3.4.4.6	Horizontal Airflow Direction Key Input Processing.....	70
5.3.4.4.7	Air Volume Key Input Processing.....	71
5.3.4.4.8	CLOCK Key Input Processing.....	72
5.3.4.4.9	TIME Key Input Processing.....	72
5.3.4.4.10	Clock Setting Key Input Processing.....	73
5.3.4.4.11	Timer Setting Key Input Processing.....	77
5.3.4.4.12	Clock Display Update Processing.....	80
5.3.4.4.13	IR Remote Control Code Transmission Start Processing.....	81
5.3.4.4.14	IR Remote Control Code Transmission Monitor Processing.....	81

**Revision History ..... 82**

## 1. Overview

The Air Conditioner Remote Controller Reference Solution Package is provided by Seiko Epson for the S1C17 microcontroller users to efficiently design an air conditioner remote controller with less man-hours. It is intended to use of the Seiko Epson microcontroller S1C17M33, but it can easily be diverted to other S1C17M/W series microcontrollers.

This package consists of a reference board, reference software, application notes and layout data.

### 1.1 List of Components

- (1) Reference board (S5U1C17M33T1 (SVT17M33))
- (2) Reference software
- (3) Application notes (this manual)
- (3) Circuit design data
- (5) Layout design data
- (6) Metal mask Gerber data
- (7) Board Gerber data

#### 1.1.1 Hardware Configuration

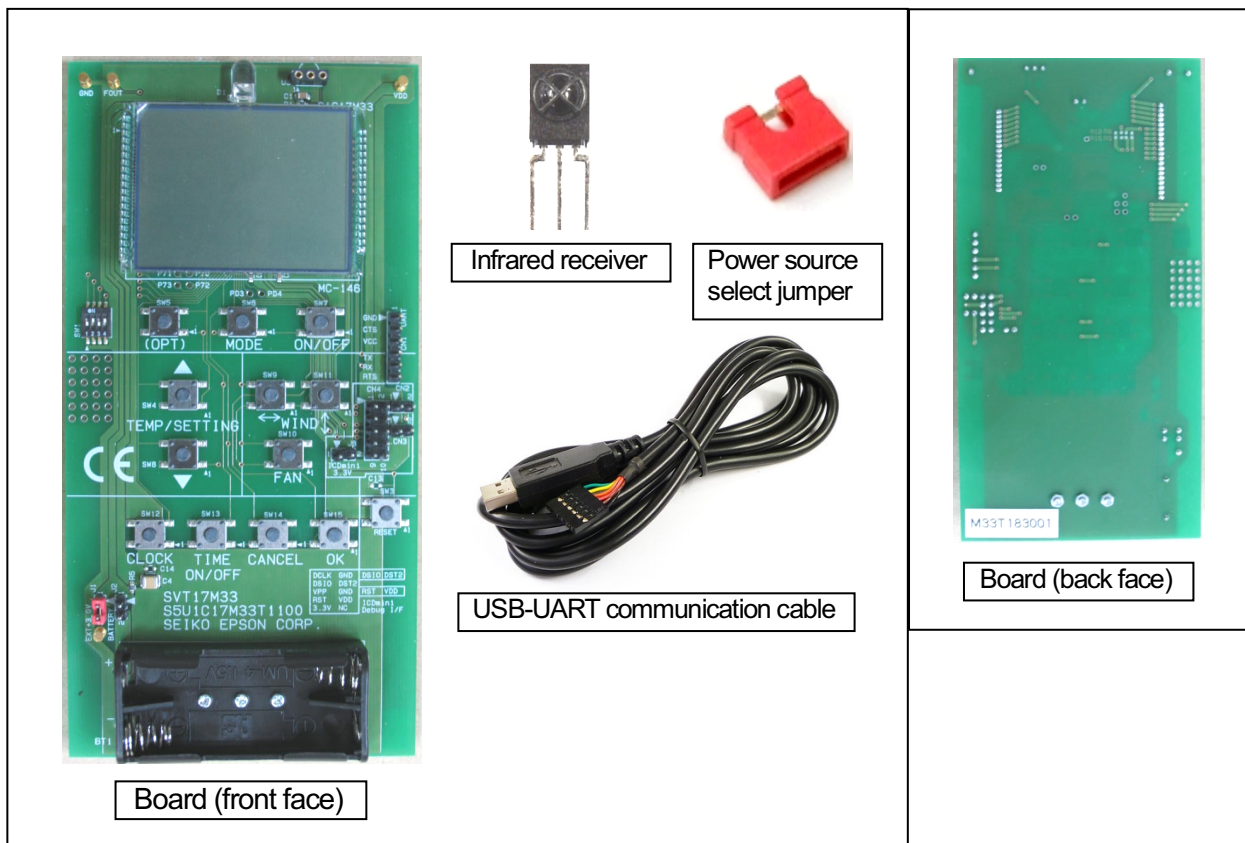

# 1. Overview

---

## 1.1.2 Software and Document Configuration

	Item	Contents	File/folder name
1	Reference software	Project file	s1c17m33_remote_sample_gnu17v3
2	Application note	Solution description Remote controller usage Circuit diagram Parts list Detailed descriptions of software	This manual

## 1.1.3 Design Data Configuration

	Item	Contents	File/folder name
1	Circuit design data	OrCAD design file	remocon_ref_board.dsn
		OrCAD netlist file	remocon_ref_board.net
		OrCAD parts list file	remocon_ref_board.bom
2	Layout design data	CADVANCE layout file	remocon_ref_board_0123-2.pcpa
		Layout file	remocon_ref_board_0123.pdf
3	Metal mask Gerber data	Plot diagram	remocon_ref_board_084725_msk.pdf
		Gerber data	remocon_ref_board_084725_msk
4	Board Gerber data	Plot diagram	remocon_ref_board_084725_pho.pdf
		Gerber data	remocon_ref_board_084725_pho
5	Mount data	Plot diagram	remocon_ref_board_mount.pdf

(These data can be downloaded from the Seiko Epson Web site.)

## 2. Reference Board

### 2.1 Hardware Specifications

MCU	Model	SEIKO EPSON S1C17M33	
	CPU	SEIKO EPSON original 16-bit RISC CPU core S1C17 included	
	Operating frequency	Maximum operating frequency: 17.12 MHz Internal oscillator: 16 MHz, 12 MHz, 700 kHz, 32 kHz External oscillator: 1 MHz to 16.8 MHz, 32.768 kHz External clock input: 0.016 MHz to 16.8 MHz Reference software setting value 12 MHz internal oscillator (-10°C to +60°C, ±2%)	
	Flash ROM	96KB	
	RAM	4KB	
	IR remote controller	Generates IR remote control signals.	
	LCD driver	46 segments × 8 commons, 50 segments × 4 commons (1/3 bias) LCD contrast: Adjustable - 16 steps	
	I/O ports	66 bits	
	Other peripheral circuits	Watchdog timer 16-bit timer 4 channels 16-bit PWM timer 3 channels Supply voltage detector UART 2 channels SPI 2 channels I <sup>2</sup> C 1 channel	Sound generator R/F converter 12-bit A/D converter 5 ports Temperature sensor Reference voltage generator Multiplier/divider Reset (#RESET pin, POR, BOR, etc.)
	Crystal resonator	For RTC	SEIKO EPSON MC-146 (32.768 kHz, C <sub>L</sub> =7 pF, ±20 ppm)
Infrared transmission LED	Forward current	100 mA (Max.)	
	Pulse forward current	1 A (Max.) (Pulse width ≤ 100 μs)	
	Radiant intensity	40 mW/Sr (Typ.)	
	Optical output power	9 mW (Typ.)	
	Directional half-value angle	15° (Typ.)	
	Sub-carrier frequency	Reference software setting value 36.7 kHz to 38 kHz (depending on the communication format of each manufacturer)	
	Communication distance	10 m or more	
	Drive circuit	Driving transistor: 1 stage Driving capability: 1 A (Max.) Current-limiting resistor: 0.51 Ω (790 mA when supply voltage = 3.5 V) • Controlled by the IR remote controller included in the MCU. • A Darlington connection pattern is provided.	
Socket for infrared receiver	Power supply	Always supplied (without ON/OFF control function)	
Infrared receiver	Sub-carrier frequency	38 kHz (center)	
LCD (original)	Number of segments	33 segments × 4 commons (= 132 segments)	
	Viewing angle	6 o'clock	
	Drive voltage	3.0 V (rated voltage: 4.0 V)	
	Frame rate	64 Hz	
	Display type	FSTN (positive)	
	Illumination system	Reflection type	
	Size	AA (active area): 40.0 × 30.0 [mm] VA (viewing area): 42.0 × 32.0 [mm] External size: 49.4 × 35.0 [mm]	
Switch	Remote controller operation key	12	
	Reset button	1	
	DIP switch	4 bits	
External interface	Flash programming/debugging	SEIKO EPSON ICDmini Ver. 2/Ver. 3 combination interface	
	UART	UART (The signal voltage is the same as the MCU power supply voltage.)	
Through holes	For unused MCU pins	P06, P30, P31, P45, P70 to P73, PD3, PD4	
	General-purpose through holes	4 × 6 holes	

## 2. Reference Board

Monitor pin	Test pin (FOUT)	<p><u>Reference software setting value</u></p> <ul style="list-style-type: none"> <li>• MCU internal clock output (factory setting value)</li> <li>• I/O port</li> </ul>											
	Test pin (VDD)	For monitoring VDD voltage											
	GND pin	For connecting to GND											
Power supply	Source	Selectable from three sources using power source select jumpers (1) Two AAA batteries (AAA battery holder) (2) 3.0 V external power source (Power supply input pin) (3) 3.3 V supplied from ICDmini											
	Power supply input pin	For supplying external 3.0 V											
	AAA battery holder	Two AAA batteries											
	Operating voltage range	<table border="1"> <thead> <tr> <th>Min.</th> <th>Typ.</th> <th>Max.</th> </tr> </thead> <tbody> <tr> <td>1.8 V</td> <td>3.0 V</td> <td>3.5 V</td> </tr> </tbody> </table> <p>(Typ. 25°C)</p> <ul style="list-style-type: none"> <li>• The upper limit voltage depends on the current limiter between the MCU and the LED drive transistor. Or 1.8 V to 3.3 V when the USB-UART communication cable is used.</li> <li>• See the figure below for the operating voltage range of each part.</li> </ul>	Min.	Typ.	Max.	1.8 V	3.0 V	3.5 V					
Min.	Typ.	Max.											
1.8 V	3.0 V	3.5 V											
Current consumption [Typ. 25°C, 3.0 V]	During standby	0.9 μA (Typ.) (Approximately 400 μA when an infrared receiver is mounted.)  <u>Reference software setting condition</u> RTC and the supply voltage monitor are operating.											
	During operation	500 μA (Typ.) (Approximately 1.0 mA when an infrared receiver is mounted.)  <u>Reference software setting condition</u> Operating with the 12 MHz clock											
	During infrared transmission	<table border="1"> <thead> <tr> <th>Power supply voltage</th> <th>Peak value</th> <th>Average value</th> </tr> </thead> <tbody> <tr> <td>3.5 V</td> <td>790 mA</td> <td>100 mA</td> </tr> <tr> <td>3.0 V</td> <td>700 mA</td> <td>80 mA</td> </tr> <tr> <td>1.8 V</td> <td>500 mA</td> <td>60 mA</td> </tr> </tbody> </table>	Power supply voltage	Peak value	Average value	3.5 V	790 mA	100 mA	3.0 V	700 mA	80 mA	1.8 V	500 mA
Power supply voltage	Peak value	Average value											
3.5 V	790 mA	100 mA											
3.0 V	700 mA	80 mA											
1.8 V	500 mA	60 mA											
Board	Number of layers	Double sided board, two layers											
	Wiring	Carbon wiring on a one-sided board, which is often used for remote controller circuit boards, to resemble 2-layer wiring (Carbon wiring is assumed for the back face.)											
Dimensions	75(W) × 150(D) × 15(H) [mm]												

### Operating voltage range for each part

Determine the optimal power supply voltage according to the function to be used.

	Min.			Typ.			Max.	
	1.8 V	2.4 V	2.7 V	3.0 V	3.3 V	3.5 V	5.5 V	
MCU								
Infrared transmission LED								
Infrared receiver								
USB-UART communication cable								

(The operating voltage range when using the USB-UART communication cable is that supported by the UART side.)

	Within operating voltage range
	Range causing performance deterioration
	Out of operating voltage range

2.2 Name and Function of Each Part

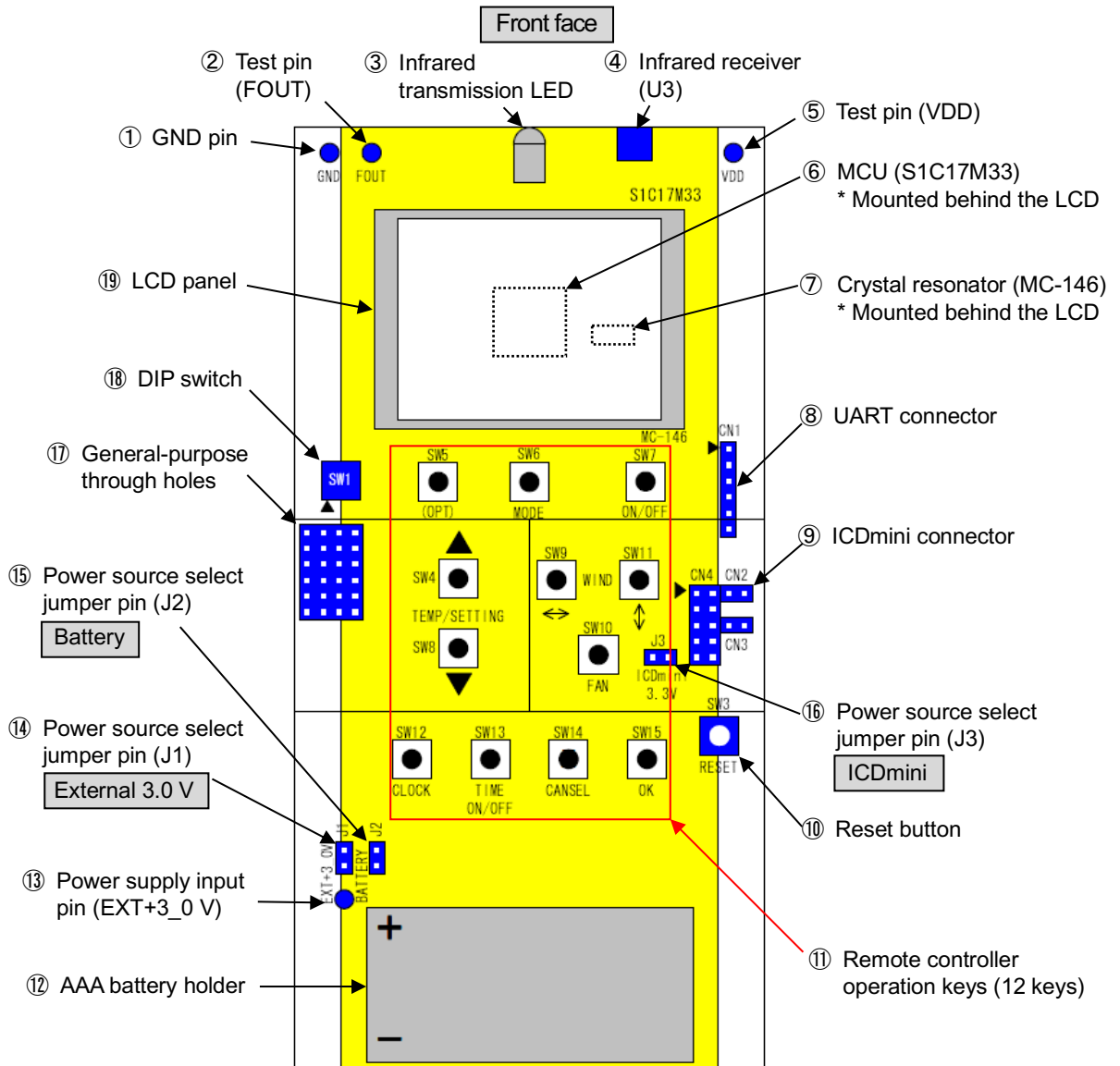

\* The area indicated in yellow is assumed to be used in an actual remote controller product.  
 The parts indicated in blue are added for convenience and debugging.  
 (In the actual product, the ICD mini connector should be implemented as a test pad.)

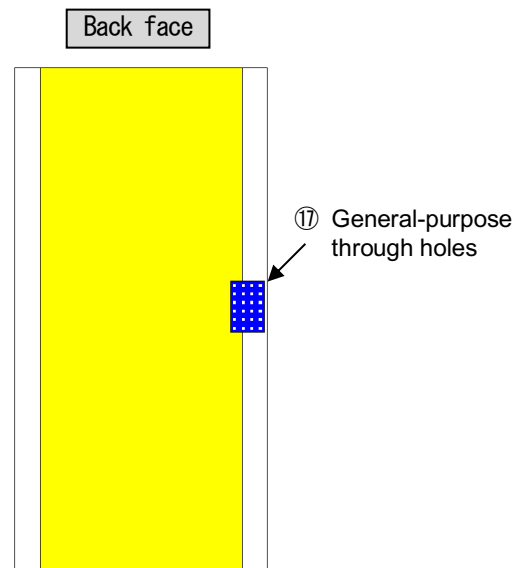

## 2. Reference Board

### Descriptions of Parts Shown in External View

	Name	Description
①	GND pin	Pin for connecting to GND
②	Test pin (FOUT)	Outputs a 32.768 kHz clock in test mode. Use this pin for the clock output to optimize matching with the resonator or a trigger output.
③	Infrared transmission LED	Infrared LED
④	Socket for infrared receiver	Used to mount the supplied infrared receiver to receive IR remote control signals.
⑤	Test pin (VDD)	Used to monitor the supply voltage.
⑥	MCU (S1C17M33)	SEIKO EPSON microcontroller S1C17M33
⑦	Crystal resonator (MC-146)	SEIKO EPSON crystal resonator MC-146 (32.768 kHz, C <sub>L</sub> = 7 pF, ±20 ppm)
⑧	UART connector	Used to connect with a PC using the supplied USB-UART communication cable. This makes it possible to control infrared transmission/reception from the PC in terminal mode.
⑨	ICDmini connector	Used to connect with an emulator (ICDmini) for writing firmware or debugging.
⑩	Reset button	Used to reset the MCU (S1C17M33).
⑪	Remote controller operation keys	Used to operate the air conditioner.
⑫	AAA battery holder	Insert two AAA batteries when supplying power from the batteries.
⑬	Power supply input pin (EXT+3_0V)	Used to supply power externally.
⑭	Power source select jumper pin (J1)	Short this jumper when supplying power externally.
⑮	Power source select jumper pin (J2)	Short this jumper when supplying power from the battery.
⑯	Power source select jumper pin (J3)	Short this jumper when supplying power from ICDmini.
⑰	General-purpose through holes	Multipurpose 24 through holes (4 columns × 6 rows) used to mount additional parts.
⑱	DIP switch	Used to switch the remote controller operation mode.
⑲	LCD panel	Original LCD panel for air conditioner remote controller.

### Description of Remote Controller Operation Keys

SW No.	Name	Description
SW7	ON/OFF	Air conditioner power ON/OFF key
SW6	MODE	Operation mode select key (AUTO/Cool/Heat/Fan/Dry)
SW4	TEMP/SETTING▲	Temperature adjustment key (Pressing this key increases the set temperature by 1°C.)
SW8	TEMP/SETTING▼	Temperature adjustment key (Pressing this key decreases the set temperature by 1°C.)
SW9	WIND↔	Vertical airflow direction adjustment key (5 steps or AUTO)
SW11	WIND↕	Horizontal airflow direction adjustment key (5 steps or AUTO)
SW10	FAN	Air volume adjustment key (6 steps or AUTO)
SW12	CLOCK	Clock setting key
SW13	TIME ON/OFF	Timer setting keys
SW14	CANCEL	Setting cancel key
SW15	OK	Determination key
SW5	(OPT)	Reserved

## 2.3 Connectors and Through Holes

### 2.3.1 ICDmini connector

When performing flash programming or debugging, connect between the ICDmini connector on this reference board and an ICDmini, and between the ICD mini and a PC.

For more information, refer to the manuals below that can be downloaded from our Web site.

- S5U1C17001H2 (ICDmini Ver2.0) User Manual
- S5U1C17001H3 (ICDmini Ver3.0) User Manual



### Caution

Be sure to avoid removing/inserting the cable from/to the connector while power is turned on, as it may cause a malfunction.

#### Connecting with ICDmini Ver. 2

Connect this board with an ICDmini Ver. 2 as shown below.

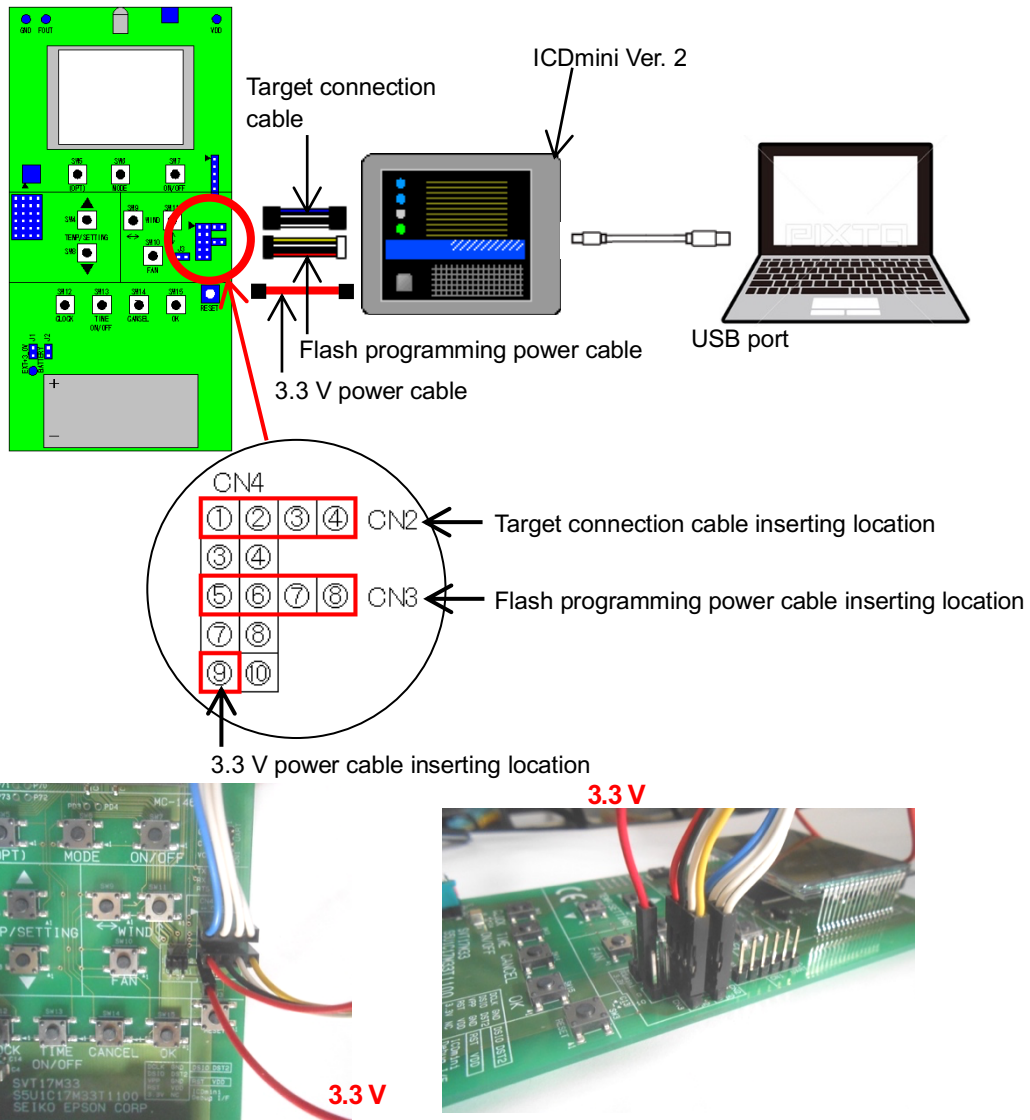

## 2. Reference Board

---

### Target Connector (4-pin)

Pin No.	Signal name	I/O	Description	Wire color
1	DCLK	I	Clock signal for debugging	Blue
2	GND	–	Ground	White
3	DSIO	I/O	Serial communication input/output signal for debugging	White
4	DST2	I	Debug status signal	White

### Flash Programming Power Connector (4-pin)

Pin No.	Signal name	I/O	Description	Wire color
1	FLASH_VCC_OUT	O	Flash memory programming voltage output	Red
2	GND	–	Ground	Black
3	TARGET_RST_OUT	O	Target reset signal output	White
4	TARGET_VCC_IN	I	Target voltage input	Yellow

\* I/O shows the signal direction viewed from the cable side. (I: Board → cable, O: Cable → board)

### Connecting with ICDmini Ver. 3

Connect this board with an ICDmini Ver. 3 as shown below.

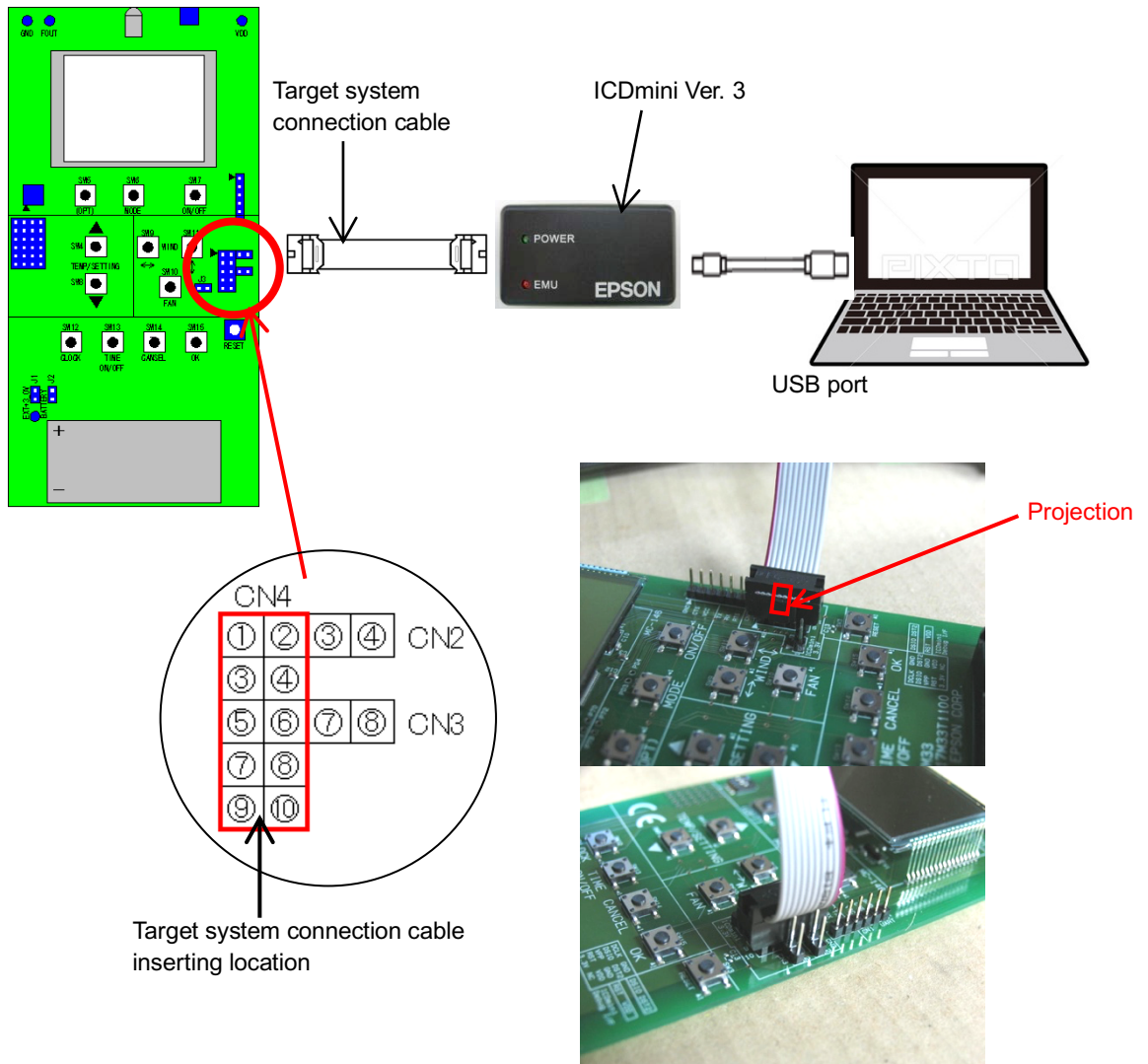

### Target System Connector (10-pin)

Pin No.	Signal name	I/O	Description
1	DCLK	I	Clock signal for debugging
2	GND	-	Ground
3	DSIO	I/O	Serial communication input/output signal for debugging
4	DST2	I	Debug status signal
5	FLASH_VCC_OUT	-	Flash memory programming voltage output
6	GND	-	Ground
7	TARGET_RST_OUT	O	Target reset signal output
8	TARGET_VCC_IN	-	Target voltage input
9	VCC3.3V	-	Power supply (3.3 V)
10	N.C	-	Unused

\* I/O shows the signal direction viewed from the cable side. (I: Board → cable, O: Cable → board)

## 2. Reference Board

### 2.3.2 UART Connector

When controlling infrared transmission/reception from a PC, connect between the UART connector on this board and the USB connector of the PC using the attached USB-UART communication cable.



#### Caution

Be sure to avoid removing/inserting the cable from/to the connector while power is turned on, as it may cause a malfunction.

#### UART Connector

Pin No.	Signal name	I/O	Description	Voltage range [V]	Wire color
1	GND	–	GND	–	Black
2	CTS#	I	Ready to send	1.5 to 3.3	Brown
3	VCC	O	USB power [+5 V] (unused)	4.25 to 5.25	Red
4	TXD	O	Transmit data	2.2 to 3.2	Orange
5	RXD	I	Receive data	1.5 to 3.3	Yellow
6	RTS#	O	Request to send	2.2 to 3.2	Green

\* I/O shows the signal direction viewed from the cable side. (I: Board → cable, O: Cable → board)

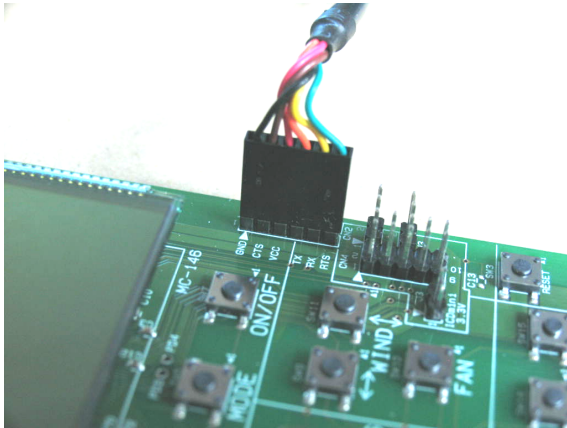

### 2.3.3 Infrared Receiver Socket

When using the attached infrared receiver, insert it to this socket by following the descriptions below.

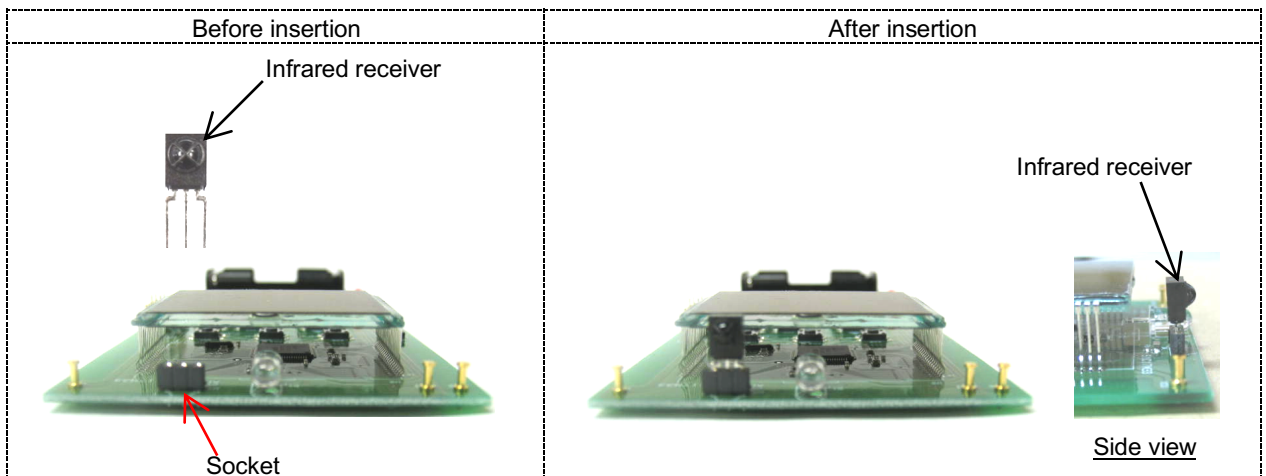

### Precautions

When handling the infrared receiver, make sure to note the following points:

1. Be aware that dirt on the infrared receiving surface due to dust and the like may cause a malfunction. Therefore, do not touch the infrared receiving surface. If it becomes dirty, wipe the dirt off with a soft cloth so that the surface is not damaged. Also do not use a solvent other than methyl alcohol, ethyl alcohol, or isopropyl alcohol.
2. Do not apply unnecessary force to the pins.

### 2.3.4 LCD Power Supply

The LCD power supply in the MCU is set to internal generation mode with the necessary external parts attached. When using the LCD driver in an external voltage application mode, mount resistors (R8, R9, R10, and R12) of around 100 k $\Omega$  on the back surface of the board (see the photos shown below). The resistance value should be determined by balancing the LCD contrast and current consumption.

This board was designed so that the LCD drive voltages are always generated when the resistors are mounted. To stop current to flow through these resistors while the LCD is off, for example, use a GPIO output as the LCD power supply.

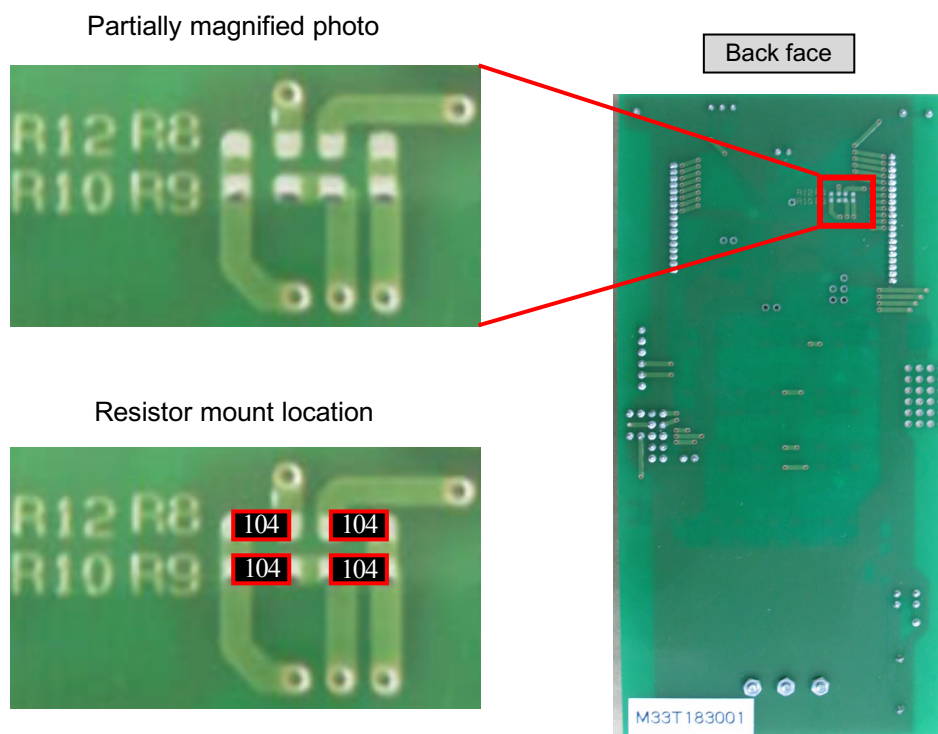

## 2. Reference Board

### 2.3.5 Through Holes

The reference board does not use 10 I/O ports of the MCU. These ports have been connected to the general-purpose through holes, so they can be used to expand board functions by attaching parts and jumper wires to the through holes on the back face.

The figure below shows the through hole locations and the port names.

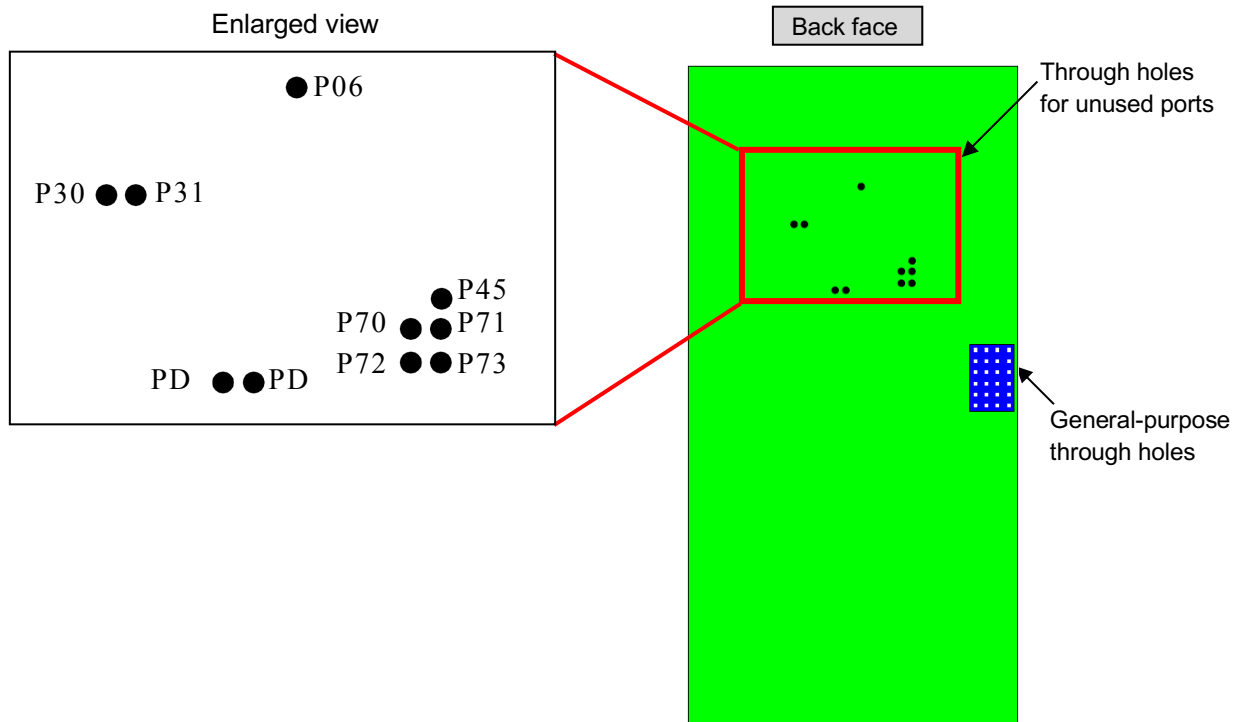

## 2.4 Power Supply

This board supports three power sources.

To select the power source to be used, short the jumper pins for selecting the power source with a jumper socket.

	Power source	Jumper	To use the power source
1	3.0 V external power supply	J1	Supply 3.0 V to the power supply input pin (EXT+3_0V) and connect the ground of the external power supply to the GND pin.
2	Battery	J2	Insert two AAA batteries into the battery holder.
3	ICDmini	J3	Connect an ICDmini to the ICDmini connector.

After turning power on, the reference board enters standby mode.

Pressing the ON/OFF key puts it into running mode.

Pressing the ON/OFF key again returns it to standby mode.

Pressing the reset button unconditionally puts it into standby mode.



### Caution

Be sure to avoid performing infrared transmission when power is supplied from an ICDmini, as it requires more than 100 mA that exceeds the current supply capability of the 3.3 V power supply included in the ICEmini.

## 2. Reference Board

### 2.5 Circuit Diagram

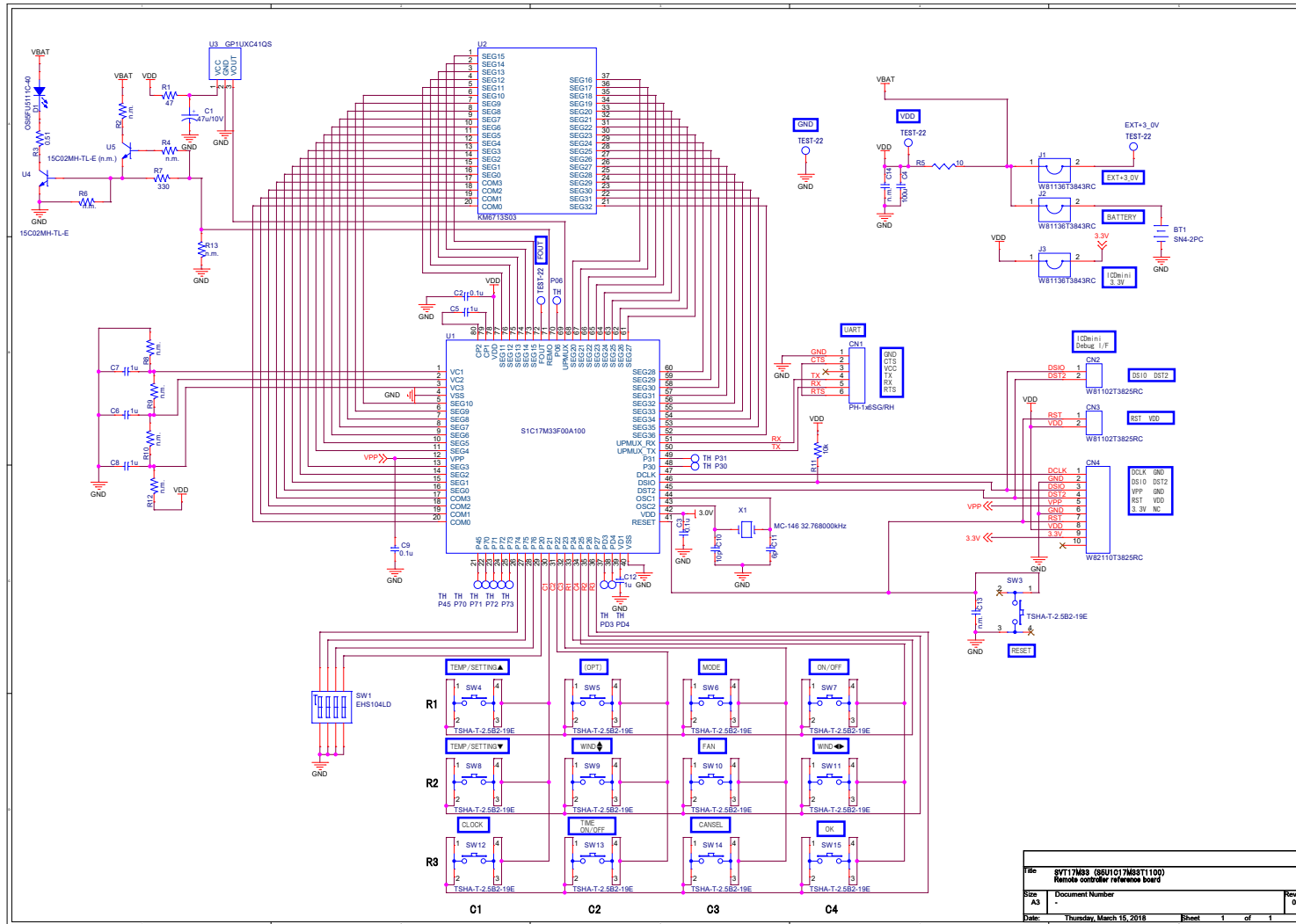

2.6 LCD Wiring Diagram

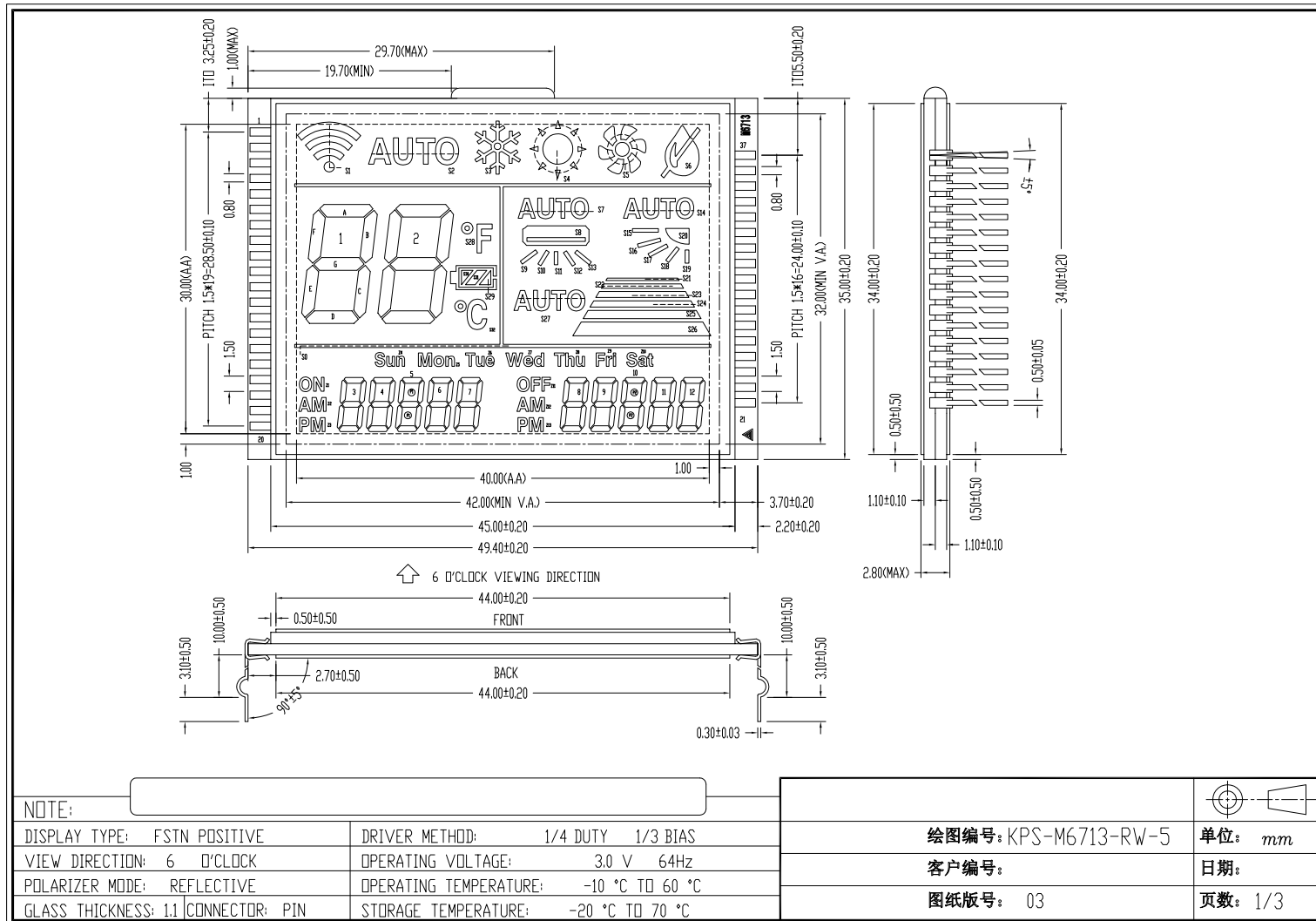

## 2. Reference Board

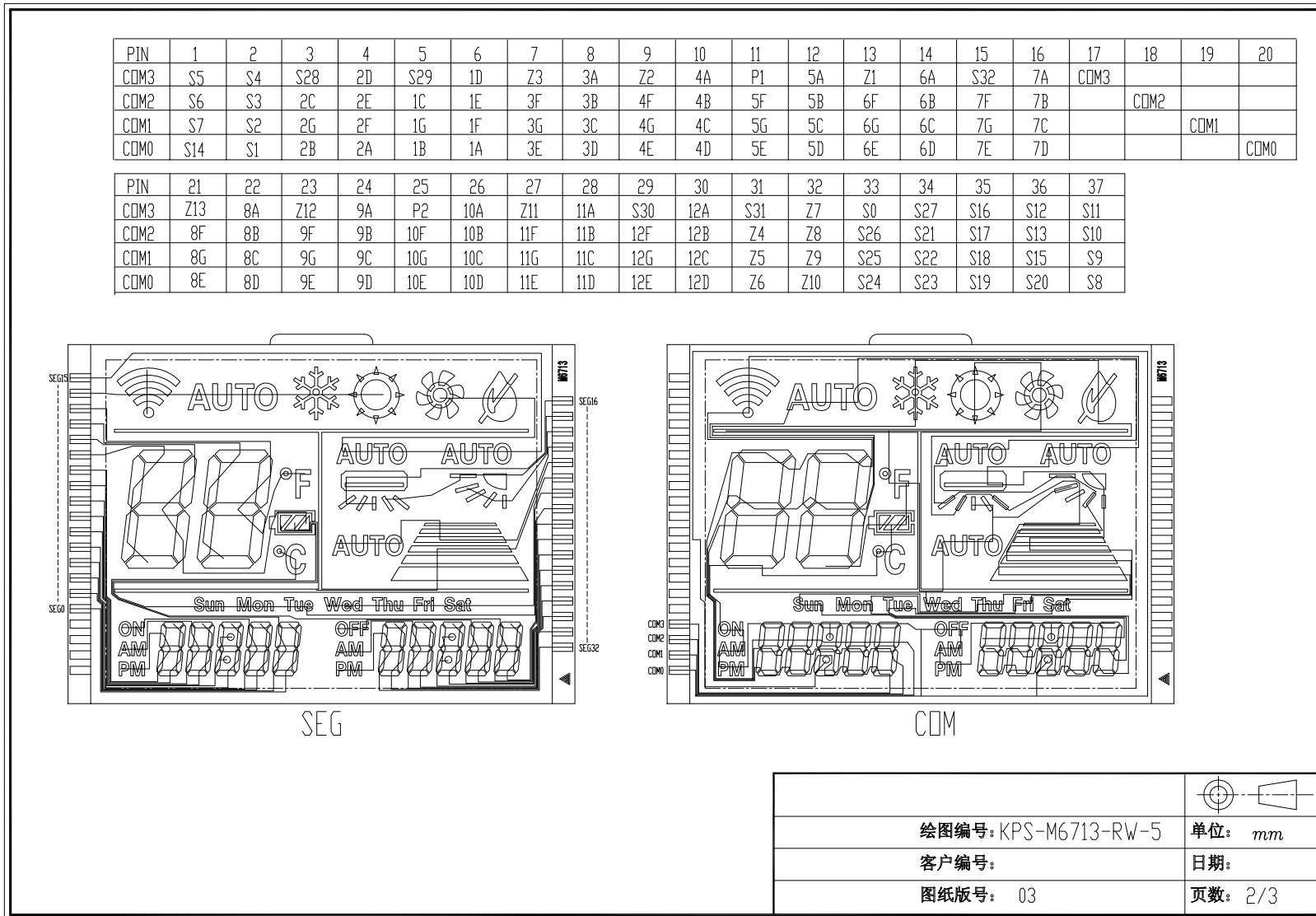

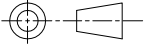
	
绘图编号: KPS-M6713-RW-5	单位: mm
客户编号:	日期:
图纸版数: 03	页数: 2/3

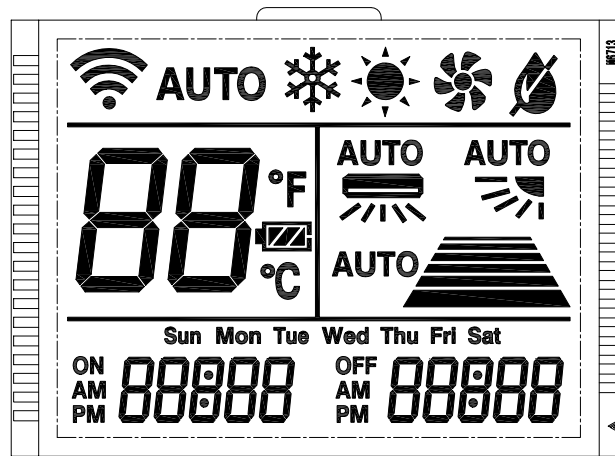

6 Pcs Crossing Points IN V.A.  
(0.05mmX0.05mm)

绘图编号: KPS-M6713-RW-5	单位: mm
客户编号:	日期:
图纸版号: 03	页数: 3/3

## 2. Reference Board

### 2.7 Parts List

No.	Part name	Model name	Specification	RoHS	Manufacturer	Reference	Qty	Remarks
1	Test pin	TEST-22		○	Kang Yang Hardware Enterprises Co., Ltd.	+3 0V, GND, FOUT, EXT+3 0V	4	
2	Battery holder	SN4-2PC		○	Takachi Electronics Enclosure Co., Ltd.	BT1	1	
3	Pin header	PH-1x6SG/RH		○	Useconn Electronics Ltd.	CN1	1	
4	Pin header	W81102T3825RC		○	RS Components Ltd.	CN2, CN3	2	
5	Pin header	W82110T3825RC		○	RS Components Ltd.	CN4	1	
6	Capacitor 47 μ/10 V	GRM21BR61A476ME15L	10 V, ±20%, X5R, 2012	○	Murata Manufacturing Co., Ltd.	C1	1	
7	Capacitor 0.1 μ	GRM188B31H104KA92D	50 V, ±10%, B, 1608	○	Murata Manufacturing Co., Ltd.	C2, C3, C9	3	
8	Capacitor 100 μ/6.3 V	GRM32ER61A107ME20L	10 V, ±20%, X5R, 3225	○	Murata Manufacturing Co., Ltd.	C4	1	
9	Capacitor 1 μ	GRM188B10J105KA01D	6.3 V, ±10%, B, 1608	○	Murata Manufacturing Co., Ltd.	C5, C6, C7, C8, C12	5	
10	Capacitor 10 p	GRM1882C1H100JA01D	50 V, ±5%, B, 1608	○	Murata Manufacturing Co., Ltd.	C10	1	
11	Capacitor 6 p	GRM1882C1H6R0DA01D	50 V, ±0.5 pF, CH, 1608	○	Murata Manufacturing Co., Ltd.	C11	1	
12	Infrared LED	OSI5FU5111C-40		○	OptoSupply Limited	D1	1	
13	Jumper socket	2228AG-RD		○	RS Components Ltd.	J1	1	
14	Resistor 47 Ω	RK73B1JTDD470J	0.125 W, ±5%, 1608	○	KOA Corporation	R1	1	
15	Resistor 0.51 Ω	ERJB2BFR51V	1 W ±1%, 3216	○	Panasonic Corporation	R3	1	
16	Resistor 330 Ω	RK73B1JTDD331J	0.125 W, ±5%, 1608	○	KOA Corporation	R7	1	
17	Resistor 10 Ω	RK73B1JTDD100J	0.125 W, ±5%, 1608	○	KOA Corporation	R5	1	
18	Resistor 10 kΩ	RK73B1JTDD103J	0.1 W, ±5%, 1608	○	KOA Corporation	R11	1	
19	Resistor/Capacitor	n.m.				R2, R4, R6, R8, R9, R10, R12, R13, C13, C14	10	
20	DIP switch	EHS104LD		○	Excel Cell Electronics Co., Ltd.	SW1	1	
21	Tact switch	TSHA-T-2.5B2-19E		○	Top-Up Industry Corporation	SW3, SW4, SW5, SW6, SW7, SW8, SW9, SW10, SW11, SW12, SW13, SW14, SW15	13	
22	LCD panel	KM6713S03		○		U2	1	
23	Microcontroller	S1C17M33F00A100		○	Seiko Epson Corporation	U1	1	
24	Infrared receiver	GP1UXC41QS		○	Sharp Corporation	U3	1	Not mounted
25	Transistor	15C02MH-TL-E		○	ON Semiconductor	U4, U5	1	U5 is not mounted.
26	Crystal resonator	MC-146 32.768000kHz 7.0+20.0-20.0		○	Seiko Epson Corporation	X1	1	
27	Screw	F-0206-E	M2 × 6 pan head, iron	○	Hirosugi-Keiki Co., Ltd.		3	
28	Nut	FNT-02E	M2, iron, hexagonal nut (1 type)	○	Hirosugi-Keiki Co., Ltd.		3	
29	Pin header	W81136T3843RC	36P	○	RS Components Ltd.	J1, J2, J3	0.167	Mounted by separating into two-pin headers
30	IC socket	801-87-006-10-012101	6P	○	Preci-Dip SA	U3	0.5	Mounted by separating into a three-pin socket
31	USB-serial conversion cable	TTL-232R-3V3			Future Technology Devices International Ltd.		1	
32	Cardboard box	G4023	178 × 123 × 46 mm		earthdanball		1	
33	Bubble bag	6310			earthdanball		1	
34	Cushioning material	1106	Outer dimensions φ 600 × 1400 mm		earthdanball		1	

---

### 3. System Resources

#### 3.1 Microcontroller Resources

Item	Resource usage		Remarks
CPU	S1C17M33		
ROM capacity	96K bytes		
RAM capacity	4K bytes		
System clock	12 MHz (OSC3 internal oscillator)		
ROM usage	Max.	33.3K bytes	When all modes are used
	Remote controller mode	22.8K bytes	
	Demonstration mode	24.2K bytes	Remote controller mode is included.
	Terminal mode	25.9K bytes	
	Test mode	27.7K bytes	Terminal mode is included.
RAM usage	Max.	1,696 bytes	Stack is included.
	Remote controller mode	948 bytes	Stack is included
Stack size	412 bytes		

### 3. System Resources

---

#### 3.2 Functions Used

PORT	P21, P22, P23, and P25 are used as the key-matrix input ports. P24, P26, and P27 are used as the key-matrix output ports. P74, P75, P76, and P20 are used as the DIP SW input ports.
REMC3	The REMO output is assigned to P07 of PPORT using UPMUX. REM3 is used to transmit IR remote control codes for air conditioners.
LCD8A	LCD8A is used to control the segment LCD on the remote controller.
RTCA	RTCA is used for the clock display on the remote controller and time adjustment.
SVD3	SVD3 is used to detect the battery level.
WDT2	WDT2 is used to reboot the system when a problem that causes the program to run abnormally occurs.
T16 Ch.0	T16 Ch.0 is used as the timer for key scan.
T16 Ch.1	T16 Ch.1 is used as the timer for determining IR remote control code transmission intervals.
T16 Ch.2	T16 Ch.2 is used as the counter for measuring times in milliseconds.
T16B Ch.0	The T16B CAP0 input is assigned to P05 of PPORT using UPMUX. The T16B Ch.0 is used for capturing IR remote control codes with an infrared photodetection unit connected to CAP0.
UART3 Ch.0	The UART3 USIN0 input and USOUT0 output are assigned to P33 and P32 of PPORT, respectively, using UPMUX. UART3 Ch.0 is used for communicating with a PC.
Clock	OSC3 (12 MHz internal oscillator) is used as the system clock. The circuits that need to run while the microcontroller is in SLEEP mode, such as RTCA, use OSC1 (32.768 kHz) as their clock source.
Interrupts	This program uses the interrupts shown below.

Hardware interrupt name	Vector number	Vector address	Interrupt level setting value	Hardware interrupt flag
IR remote controller interrupt	18 (0x12)	0x8048	3	Compare DB
Port interrupt	5 (0x05)	0x8014	3	Port input
16-bit timer Ch.0 interrupt	9 (0x09)	0x8024	3	Underflow
16-bit timer Ch.1 interrupt	11 (0x0B)	0x802C	3	Underflow
16-bit timer Ch.2 interrupt	22 (0x16)	0x8058	3	Underflow
16-bit PWM timer Ch.0 interrupt	14 (0x0E)	0x8038	3	Compare/capture
LCD driver interrupt	19 (0x13)	0x804C	3	Frame
UART Ch.0 interrupt	10 (0x0A)	0x8028	3	Receive buffer one byte full, end of transmission, overrun error

## 4. Operation Mode

### 4.1 Switching Operation Mode

The reference board has four operation modes that can be switched using a DIP switch.

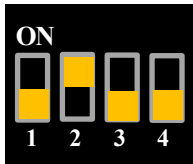

SW1

DIP SW				Operation mode
1	2	3	4	
ON	OFF	OFF	OFF	Remote controller mode
OFF	ON	OFF	ON	Terminal mode
OFF	OFF	OFF	OFF	Demonstration mode
ON	ON	ON	ON	Test mode
Other settings				Remote controller mode

Operation mode	Description
Remote controller mode	In this mode, the reference board works as a remote controller.
Terminal mode	In this mode, the reference board communicates with a PC to input/output IR remote control codes.
Demonstration mode	In this mode, the demonstration contents are displayed repeatedly. By pressing keys, the reference board works as a remote controller for an air conditioner.
Test mode	This mode is used to test the reference board hardware, switches, LCD, and infrared transmission/reception functions.

## 4. Operation Mode

### 4.2 Remote Controller Mode

The reference board works as a remote controller in this mode.

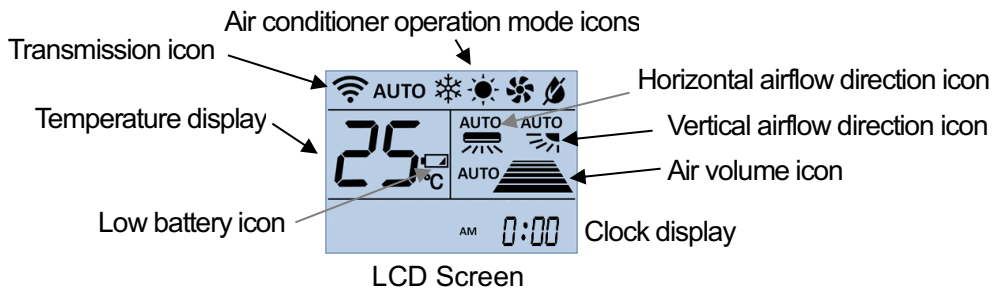

#### 4.2.1 Turning Air Conditioner On or Off

Pressing the ON/OFF (SW7) key turns the air conditioner on or off.

- (1) The air conditioner goes on when the ON/OFF key is pressed while it is off.  
At this time, the remote controller activates in normal operation state.  
The remote controller also enters normal operation mode when the clock is set or when the ON/OFF key is pressed during timer setting.
- (2) The air conditioner goes off when the ON/OFF key is pressed while it is on.  
At this time, the remote controller program turns the LCD off and puts the microcontroller into SLEEP mode with the 32.768 kHz oscillator activated for clocking.

#### 4.2.2 Normal Operation

##### 4.2.2.1 Changing Air Conditioner Operation Mode

Short pressing the MODE (SW6) key changes the air conditioner operation mode by 1 as shown below.

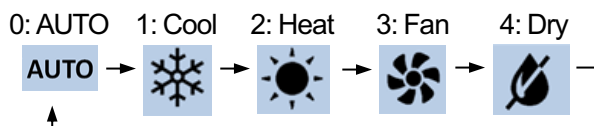

##### 4.2.2.2 Adjusting Temperature

The set temperature can be adjusted within the range from 16°C to 32°C (initially set to 25°C).

Short pressing the TEMP $\Delta$  (SW8) key increases the set temperature 1 degree. Long pressing performs fast feed of the setting value.

Short pressing the TEMP $\nabla$  (SW4) key lowers the set temperature 1 degree. Long pressing performs fast feed of the setting value.

##### 4.2.2.3 Adjusting Vertical Airflow Direction

Short pressing the WIND $\uparrow$  (SW11) key changes the vertical airflow (flap) direction as shown below.

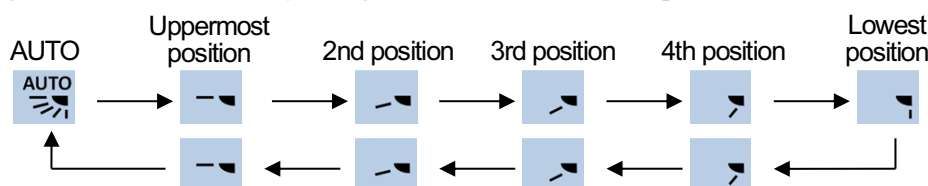

### 4.2.2.4 Adjusting Horizontal Airflow Direction

Short pressing the WIND↔ (SW9) key changes the horizontal airflow (flaps) direction as shown below.

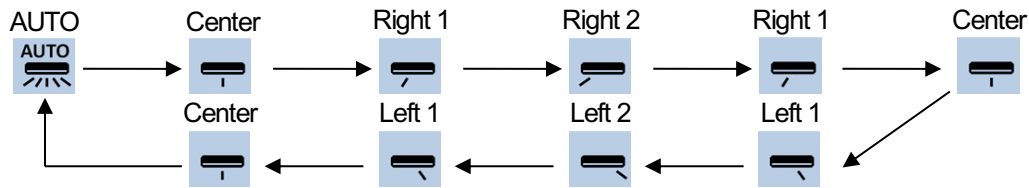

### 4.2.2.5 Adjusting Air Volume

Short pressing the WIND FAN (SW10) key increases the air volume by 1 step as shown below.

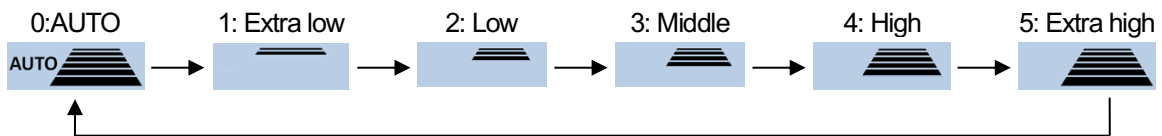

### 4.2.2.6 Displaying Date

Short pressing the CLOCK (SW12) key displays year, month, and day for 3 seconds on the clock display portion at the lower part of the LCD

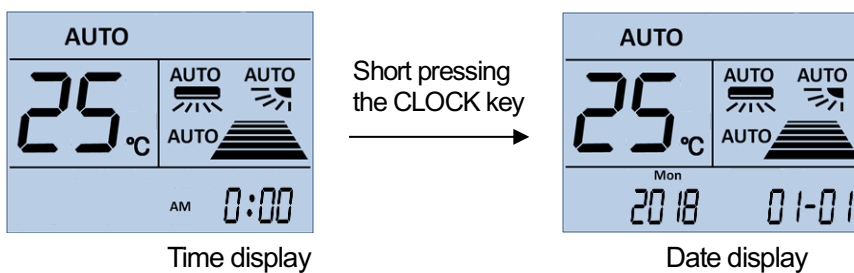

### 4.2.2.7 Displaying Timer Settings

Short pressing the TIME (SW13) key displays the set reservation times of the ON/OFF timers for 3 seconds on the clock display portion at the lower part of the LCD.

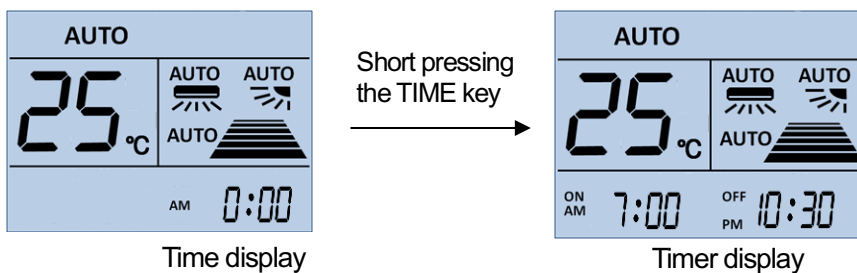

### 4.2.2.8 Switching to Clock Setting Mode

Long pressing the CLOCK (SW12) key for 2(3?) seconds puts the remote controller into clock setting mode.

### 4.2.2.9 Switching to Timer Setting Mode

Long pressing the TIME (SW13) key for 2(3?) seconds puts the remote controller into timer setting mode.

## 4. Operation Mode

### 4.2.3 Clock Settings

This section shows the key operations to set up the clock using RTC.

- (1) In clock setting mode, year, month, day, 24h/12h mode, hours, and minutes can be set in this order. The item blinks when it is able to be changed.
- (2) Key operations for setting year  
First, the year display blinks when it enters clock setting mode.



SETTING△ (SW8)	Short pressing increments the year by 1. Long pressing performs fast feed of the setting value. If the setting value exceeds 99, it reverts to the initial value.
SETTING▽ (SW4)	Short pressing decrements the year by 1. Long pressing performs fast feed of the setting value. If the setting value goes below the initial value, it reverts to 99.
CANCEL (SW14)	Cancels clock setting mode and returns to normal operation mode.
OK (SW15)	Moves the blink position (setting position) to the month.

- (3) Key operations for setting month



SETTING△ (SW8)	Short pressing increments the month by 1. Long pressing performs fast feed of the setting value. If the setting value exceeds 12 (December), it reverts to 1 (January).
SETTING▽ (SW4)	Short pressing decrements the month by 1. Long pressing performs fast feed of the setting value. If the setting value goes below 1 (January), it reverts to 12 (December).
CANCEL (SW14)	Moves the blink position (setting position) to the year.
OK (SW15)	Moves the blink position (setting position) to the day.

- (4) Key operations for setting day



SETTING△ (SW8)	Short pressing increments the day by 1. Long pressing performs fast feed of the setting value. If the setting value exceeds the last day of the month, it reverts to 1.
SETTING▽ (SW4)	Short pressing decrements the day by 1. Long pressing performs fast feed of the setting value. If the setting value goes below 1, it reverts to the last day of the month.
CANCEL (SW14)	Moves the blink position (setting position) to the month.
OK (SW15)	Moves the blink position (setting position) to the 24h/12h mode.

- (5) Key operations for setting 24h/12h mode



SETTING△ (SW8)	Short pressing toggles between 24h and 12h modes.
SETTING▽ (SW4)	
CANCEL (SW14)	Moves the blink position (setting position) to the day.
OK (SW15)	Moves the blink position (setting position) to the hour.

### (6) Key operations for setting hours



SETTING△ (SW8)	Short pressing increments the hour by 1. Long pressing performs fast feed of the setting value. If the setting value exceeds 23 in 24h mode or 11 in 12h mode, it reverts to 0. Also the AM/PM display is toggled in 12h mode.
SETTING▽ (SW4)	Short pressing decrements the hour by 1. Long pressing performs fast feed of the setting value. If the setting value goes below 0, it reverts to 23 in 24h mode or 11 in 12h mode. Also the AM/PM display is toggled in 12h mode.
CANCEL (SW14)	Moves the blink position (setting position) to the 24h/12h mode.
OK (SW15)	Moves the blink position (setting position) to the minute.

### (7) Key operations for setting minutes



SETTING△ (SW8)	Short pressing increments the minute by 1. Long pressing performs fast feed of the setting value. If the setting value exceeds 59, it reverts to 0.
SETTING▽ (SW4)	Short pressing decrements the minute by 1. Long pressing performs fast feed of the setting value. If the setting value goes below 0, it reverts to 59.
CANCEL (SW14)	Moves the blink position (setting position) to the hour.
OK (SW15)	Updates the RTC clock setting and returns to normal operation mode.

## 4. Operation Mode

### 4.2.4 Timer Settings

This section shows the key operations to set timer reservations.

- (1) When timer setting mode is entered, first all the setting items blink. Then, ON timer selection, ON timer hour setting, ON timer minute setting, OFF timer selection, OFF timer hour setting, OFF timer minute setting can be done in this order. The item blinks when it is able to be changed.
- (2) Key operations when all items are blinking  
First, all the setting items blink when timer setting mode is entered.



CANCEL (SW14)	Cancels timer setting mode and returns to normal operation mode.
OK (SW15)	Moves the blink position (setting position) to the ON timer selection.

- (3) Key operations for selecting/canceling ON timer



SETTING△ (SW8)	Short pressing toggles between ON timer selected and ON timer canceled.
SETTING▽ (SW4)	Canceling the ON timer displays "--:--"; selecting the ON timer displays the reservation time.
CANCEL (SW14)	Cancels timer setting mode and returns to normal operation mode.
OK (SW15)	When the ON timer is canceled, pressing this key moves the blink position (setting position) to the OFF timer selection. When the ON timer is selected, pressing this key moves the blink position (setting position) to the hour of the ON timer.

- (4) Key operations for setting hour of ON timer



SETTING△ (SW8)	Short pressing increments the hour by 1. Long pressing performs fast feed of the setting value. If the setting value exceeds 23 in 24h mode or 11 in 12h mode, it reverts to 0. Also the AM/PM display is toggled in 12h mode.
SETTING▽ (SW4)	Short pressing decrements the hour by 1. Long pressing performs fast feed of the setting value. If the setting value goes below 0, it reverts to 23 in 24h mode or 11 in 12h mode. Also the AM/PM display is toggled in 12h mode.
CANCEL (SW14)	Moves the blink position (setting position) to the ON timer selection.
OK (SW15)	Moves the blink position (setting position) to the minute of the ON timer.

- (5) Key operations for setting minute of ON timer



SETTING△ (SW8)	Short pressing increments minute by 1. Long pressing performs fast feed of the setting value. If the setting value exceeds 59, it reverts to 0.
SETTING▽ (SW4)	Short pressing decrements minute by 1. Long pressing performs fast feed of the setting value. If the setting value goes below 0, it reverts to 59.
CANCEL (SW14)	Moves the blink position (setting position) to the hour of the ON timer.
OK (SW15)	Moves the blink position (setting position) to the OFF timer selection.

### (6) Key operations for selecting/canceling OFF timer

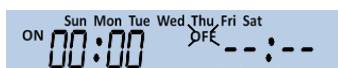

SETTING△ (SW8)	Short pressing toggles between OFF timer selected and OFF timer canceled. Canceling the
SETTING▽ (SW4)	OFF timer displays "--:--"; selecting the OFF timer displays the reservation time.
CANCEL (SW14)	When the ON timer has been selected, pressing this key moves the blink position (setting position) to the minute of the ON timer. When the ON timer has been canceled, pressing this key moves the blink position (setting position) to the ON timer selection.
OK (SW15)	When the OFF timer is canceled, pressing this key updates the timer setting, transmits the IR remote control code, and then returns to normal operation mode. When the OFF timer is selected, pressing this key moves the blink position (setting position) to the hour of the OFF timer.

### (7) Key operations for setting hour of OFF timer

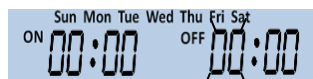
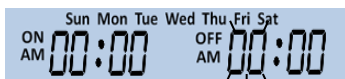

SETTING△ (SW8)	Short pressing increments the hour by 1. Long pressing performs fast feed of the setting value. If the setting value exceeds 23 in 24h mode or 11 in 12h mode, it reverts to 0. Also the AM/PM display is toggled in 12h mode.
SETTING▽ (SW4)	Short pressing decrements the hour by 1. Long pressing performs fast feed of the setting value. If the setting value goes below 0, it reverts to 23 in 24h mode or 11 in 12h mode. Also the AM/PM display is toggled in 12h mode.
CANCEL (SW14)	Moves the blink position (setting position) to the OFF timer selection.
OK (SW15)	Moves the blink position (setting position) to the minute of the OFF timer.

### (8) Key operations for setting minute of OFF timer

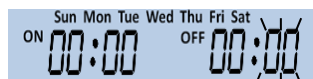
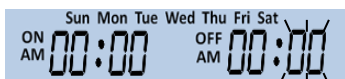

SETTING△ (SW8)	Short pressing increments the minute by 1. Long pressing performs fast feed of the setting value. If the setting value exceeds 59, it reverts to 0.
SETTING▽ (SW4)	Short pressing decrements the minute by 1. Long pressing performs fast feed of the setting value. If the setting value goes below 0, it reverts to 59.
CANCEL (SW14)	Moves the blink position (setting position) to the hour of the OFF timer.
OK (SW15)	Updates the timer setting, transmits the IR remote control code, and then returns to normal operation mode.

## 4. Operation Mode

---

### 4.3 Terminal Mode

In this mode, the reference board transmits/receives IR remote control codes by issuing the commands from the PC.

#### 4.3.1 Overview

In terminal mode, the reference board can be used to check infrared transmit/receive operations. To perform this operation check, insert the attached infrared receiver into the U3 socket. This socket is provided to remove the infrared receiver during normal use, as it increases power consumption.

(1) Communication conditions

Item	Set values
Baud rate	9600 bps
Data length	8 bits
Stop bit	1 bit
Parity	None

(2) Command format

The commands for terminal mode are an ASCII character string that consists of a command name, arguments separated with a space, and the line feed code. The number of the arguments and their format depend on each command. The argument should be entered in order of an item name that begins with a hyphen and a setting value. The character string length of a command is limited up to 126 characters. Note that issuing a command that exceeds this limitation may result in undesired behavior.

(3) List of commands

Command name	Function
led_set	Initialization command
led_snd	IR remote control code transmission command
led_rcv	IR remote control code reception command

(4) Operation check procedure

- When using a reference board alone

An infrared transmission/reception loop back test can be performed by receiving the infrared ray that was transmitted from the board and reflected from a wall face or the like.

1. Set the reference board to terminal mode.
2. Connect the board and a PC using a USB-UART communication cable.
3. Invoke a terminal software (e.g. Tera Term) on the PC to establish connection to the board.
4. Execute a reception command.
5. Execute a transmission command to transmit infrared ray.
6. When the infrared ray is received, the terminal software displays the received data.

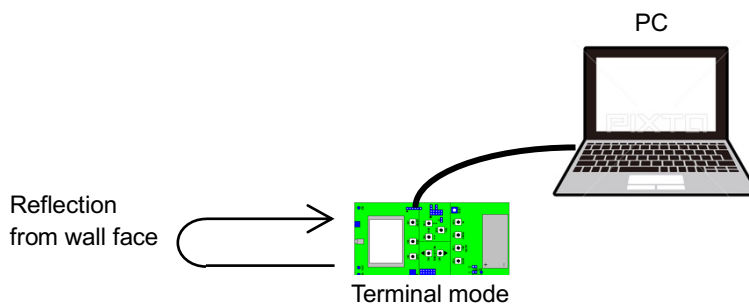

- When using two reference boards

An infrared point-to-point communication can be performed with two reference boards facing each other.

1. Set Board A to remote controller mode.
2. Set Board B to terminal mode.
3. Connect Board B and a PC using a USB-UART communication cable.
4. Invoke a terminal software (e.g. Tera Term) on the PC to establish a connection to Board B.
5. Execute a reception command.
6. Press the ON/OFF key on Board A to transmit infrared ray.
7. When the infrared ray is received with Board B, the terminal software displays the received data.

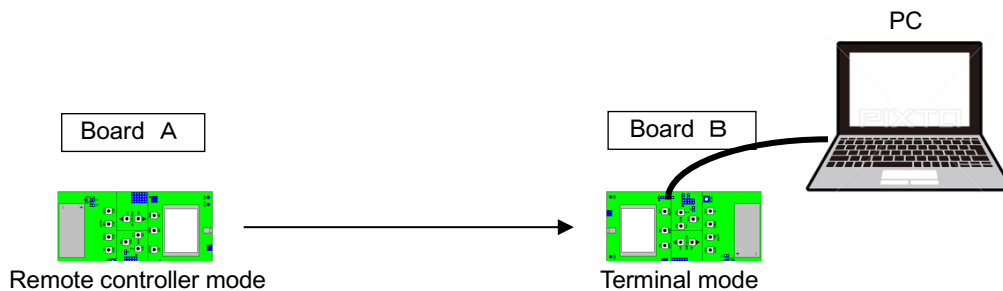

### 4.3.2 Initialization Command (led\_set)

Format:

```
led_set -format <value> -subcarrier <value> -T <value> -LH <value> -LL <value> -0H <value> -0L <value> -1H <value> -1L <value> \r
```

Arguments:

Argument name		Setting value		Initial value
format	Data bit format	nor	The data bit begins with high.	nor
		rev	The data bit begins with low.	
subcarrier	Sub-carrier	Frequency (Hz)		38000
T	T	Pulse width (μs)		425
LH	High period of leader	Number of pulses (multiplier of T)		8
LL	Low period of leader	Number of pulses (multiplier of T)		4
0H	High period of data bit "0"	Number of pulses (multiplier of T)		1
0L	Low period of data bit "0"	Number of pulses (multiplier of T)		1
1H	High period of data bit "1"	Number of pulses (multiplier of T)		1
1L	Low period of data bit "1"	Number of pulses (multiplier of T)		3

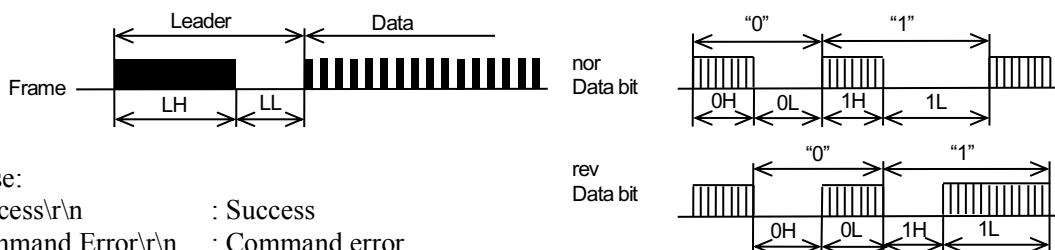

Response:

```
Success\r\n          : Success
Command Error\r\n    : Command error
```

## 4. Operation Mode

### 4.3.3 IR Remote Control Code Transmission Command (led\_snd)

Format:

```
led_snd [-P <value>] [-REP <value>] -D <value>\r
```

Arguments:

Argument name		Value
-P	Preceding data (*1)	Enter a hexadecimal data in byte units as character string. (*2)
-D	Transmit data	Enter a hexadecimal data in byte units as character string. (*2)
-REP	Repeat count	Specify the number of repeats when transmitting the same code. Specifying 1 transmits the code only once; specifying 2 transmits the code twice. When this argument is omitted, the code is transmitted only once.

\*1 Preceding data can be omitted.

When specified, the preceding data and transmit data are transmitted sequentially in this order as an IR remote control code. Preceding data can be specified up to 19 bytes.

\*2 Hexadecimal data can be specified in byte units with or without a separator (space or comma) inserted. Up to 48 bytes can be specified when entering data continuously without a separator, or up to 38 bytes when a separator is inserted.

Example:

```
led_snd -D 0102030405060708\r\n
led_snd -D 01 02 03 04 05 06 07 08\r\n
led_snd -D 01,02,03,04,05,06,07,08\r\n
```

Response:

```
Success\r\n      : Success
Command Error\r\n : Command error
```

### 4.3.4 IR Remote Control Code Reception Command (led\_rcv)

Format:

```
led_rcv [-timeout][separator]\r
```

Arguments:

Argument name		Value	
-timeout	Timeout	1 or more	Specify the number of seconds to receive data. The receive operation continues until the specified number of seconds has elapsed regardless of whether data have been received or not.
		0	The receive operation continues until the ON/OFF key is pressed.
		Omitted	
-separator	Output data separator specification	0	Without a separator
		1 (other than 0)	Output data are separated with a comma in byte units.
		Omitted	

Response:

Response when a command is received

```
Success\r\n      : Success
Command Error\r\n : Command error
```

Response (output data) when an IR remote control code is received

```
-D <data>\r
```

Example:

```
-D 01,02,03,04,05,06,07,08\r\n (separator = 1 or omitted)
-D 0102030405060708\r\n (separator = 0)
```

When the reception period has expired

```
Time out\r\n
```

### 4.4 Demonstration Mode

In this mode, the reference board displays the contents listed below repeatedly. Pressing any key while displaying demonstration contents puts the reference board into remote controller mode. If no operation occurs for 60 seconds after that, the reference board reverts to demonstration mode again.

Display contents in demonstration mode

- (1) All the LCD segments are turned on. (2 seconds)
- (2) Normal display: "23°C and all other items are set to AUTO" (2 seconds)
- (3) Clock display: "PM 1:23" (1 second)
- (4) Date display: "2018 01-23 Thu" (1 second)
- (5) ON timer display: "ON AM 7:00" (1 second)
- (6) OFF timer display: "OFF PM 11:00" (1 second)
- (7) Air conditioner operation mode and temperature display
  - (7-1) Cool 23°C, 22°C, 21°C . . . 16°C (1°C steps at 0.5 second intervals)
  - (7-2) Heat 16°C, 17°C, 18°C . . . 23°C (1°C steps at 0.5 second intervals)
  - (7-3) Fan (1 second)
  - (7-4) Dry (1 second)
  - (7-5) Fan (1 second)
  - (7-6) Heat 23°C, 24°C, 25°C . . . 32°C (1°C steps at 0.5 second intervals)
  - (7-7) Cool 32°C, 31°C, 30°C . . . 23°C (1°C steps at 0.5 second intervals)
  - (7-8) AUTO (0.5 second)

Other display items:

The following contents are repeatedly displayed during Step 7.

Horizontal airflow direction (10 patterns)

AUTO→Center→Left→Right→Left→Center→AUTO (0.5 second intervals)

Vertical airflow direction (10 patterns)

AUTO→Up→Down→U→ AUTO (0.5 second intervals)

FAN (10 patterns)

AUTO→Weak→Strong→Weak→AUTO (0.5 second intervals)

- (8) Low battery mark: Lit (1 second)
- (9) Low battery mark: Blinks in 0.5 second intervals (3 seconds)
- (10) All the LCD segments are turned off. (1 seconds)  
→ To Step 1

## 4. Operation Mode

### 4.5 Test Mode

In this mode, the reference board hardware test is performed in the procedure shown below.

(1) Start of test

The test starts by pressing the ON/OFF (SW7) key and displays a test item number in the temperature display portion.

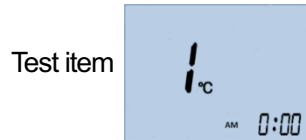

(2) Test item 1: RTC test

The RTC test displays the current time in seconds and outputs the OSC1 (32.768 kHz) clock from the test pin (FOUT).

Check if the FOUT output frequency is within the range from 32.767344 to 32.768655 kHz and time display is being updated at 1 second intervals. Then press any key to advance to the next test item.



(3) Test item 2: DIP switch test

The DIP switch test displays the DIP switch settings at the lower right of the LCD. Set the DIP switch according to the display (turn off the switch specified as 0). When four switch patterns have been set correctly, this test is terminated and the next test item starts.

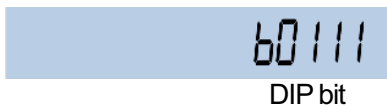

DIP switch setting order

DIP bit	Operation
b0111	Turn DIP switch bit 1 off
b0011	Turn DIP switch bit 2 off
b0001	Turn DIP switch bit 3 off
b0000	Turn DIP switch bit 4 off

(4) Test item 3: Tact switch test

The tact switch test displays a switch number at the lower right of the LCD. Pressing the specified tact switch changes the display to the next switch number to be tested. When the last switch is pressed, this test is terminated and the next test item starts.

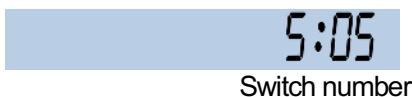

Switch setting order

Switch number	Switch to be pressed
S:05	SW5(OPT)
S:06	SW6(MODE)
S:07	SW7(ON/OFF)
S:04	SW4(TEMP/SETTING $\Delta$ )
S:09	SW9(WIND $\leftrightarrow$ )
S:11	SW11(WIND $\uparrow$ )
S:08	SW8(TEMP/SETTING $\nabla$ )
S:10	SW10(WIND FAN)
S:12	SW12(CLOCK)
S:13	SW13(TIME)
S:14	SW14(CANCEL)
S:15	SW15(OK)

(5) Test item 4: Infrared signal transmission/reception test

This is a loop back test of infrared transmission/reception. The reference board outputs data to the infrared transmitter and inputs it from the infrared receiver. If the received data matches the transmit data (sum check), this test is terminated and the next test item starts.

During testing, the transmission count is displayed at the lower right of the LCD. If a mismatch between the transmit and receive data is detected before 10 transmit/receive operations are completed, this test is canceled with “Error” displayed on the LCD.

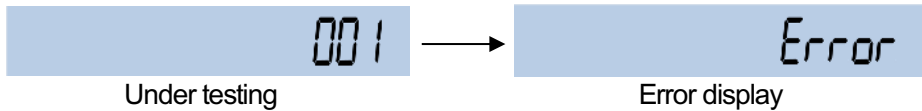

(6) Test item 5: LCD test

In this test, each segment goes on sequentially in order from the upper left of the LCD to the lower right at 500 ms intervals. After the last segment goes on, this test is terminated and the next test item starts. Pressing the OK (SW15) key during testing terminates this test and starts the next test item. Pressing the OPT (SW15) key suspends or resumes testing.

(7) Test item 6: UART test

This is a loop back test of the UART. The reference board transmits data from UART TX and receives it from UART RX. If the received data matches the transmit data (sum check), this test is terminated and the last stage starts.

During testing, the transmission count is displayed at the lower right of the LCD. If a mismatch between the transmit and receive data is detected before 10 transmit/receive operations are completed, this test is canceled with “Error” displayed on the LCD.

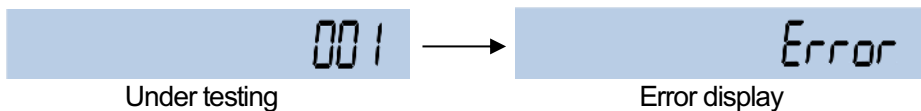

(8) Terminating test

When the test has been completed successfully, all the LCD segments go on.

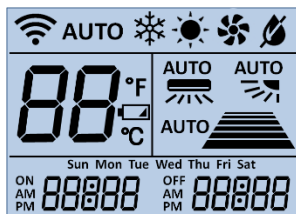

## 5. Software Description

### 5. Software Description

#### 5.1 Functional Blocks

This program consists of an application layer, a driver layer, and a middle layer that interfaces between the application layer and the driver layer.

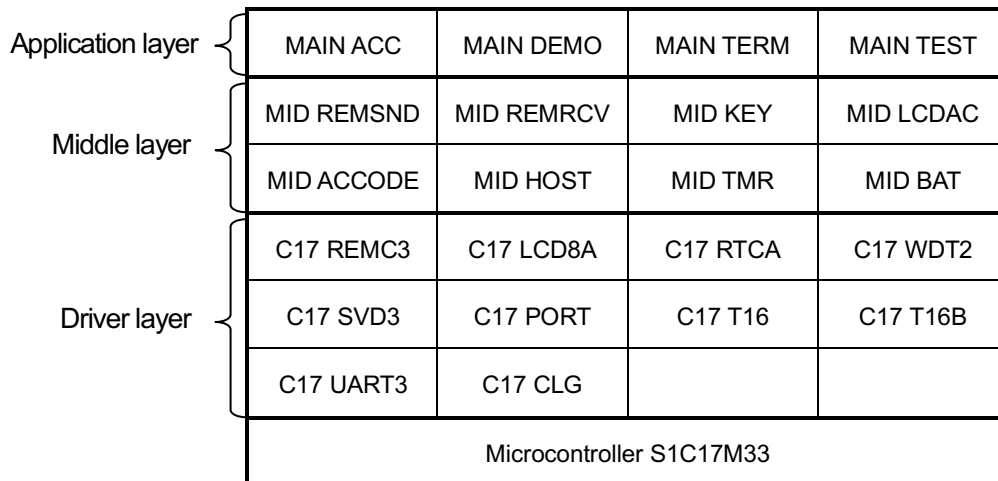

Functional Blocks

Functional block	Function
MAIN ACC	Remote controller mode (air conditioner controller)
MAIN TERM	Terminal mode (communication with PC and infrared transmission/reception)
MAIN DEMO	Demonstration mode
MAIN TEST	Test mode
MID REMSND	IR remote control code transmission interface
MID REMRCV	IR remote control code reception interface
MID KEY	Key input interface
MID LCDAC	Air conditioner LCD display interface
MID ACCCODE	Air conditioner IR remote control code conversion interface
MID HOST	PC communication interface
MID TMR	Timer counter interface
MID BAT	Battery level monitor interface
C17 CLG	CLG (osc) driver
C17 SVD3	Supply voltage detector driver
C17 WDT2	Watchdog timer driver
C17 REMC3	IR remote controller driver
C17 LCD8A	LCD driver
C17 RTCA	Real-time clock driver
C17 PORT	I/O port driver
C17 T16	16-bit timer driver
C17 T16B	16-bit PWM timer driver
C17 UART3	UART driver

5.2 Operation Schematic Diagram

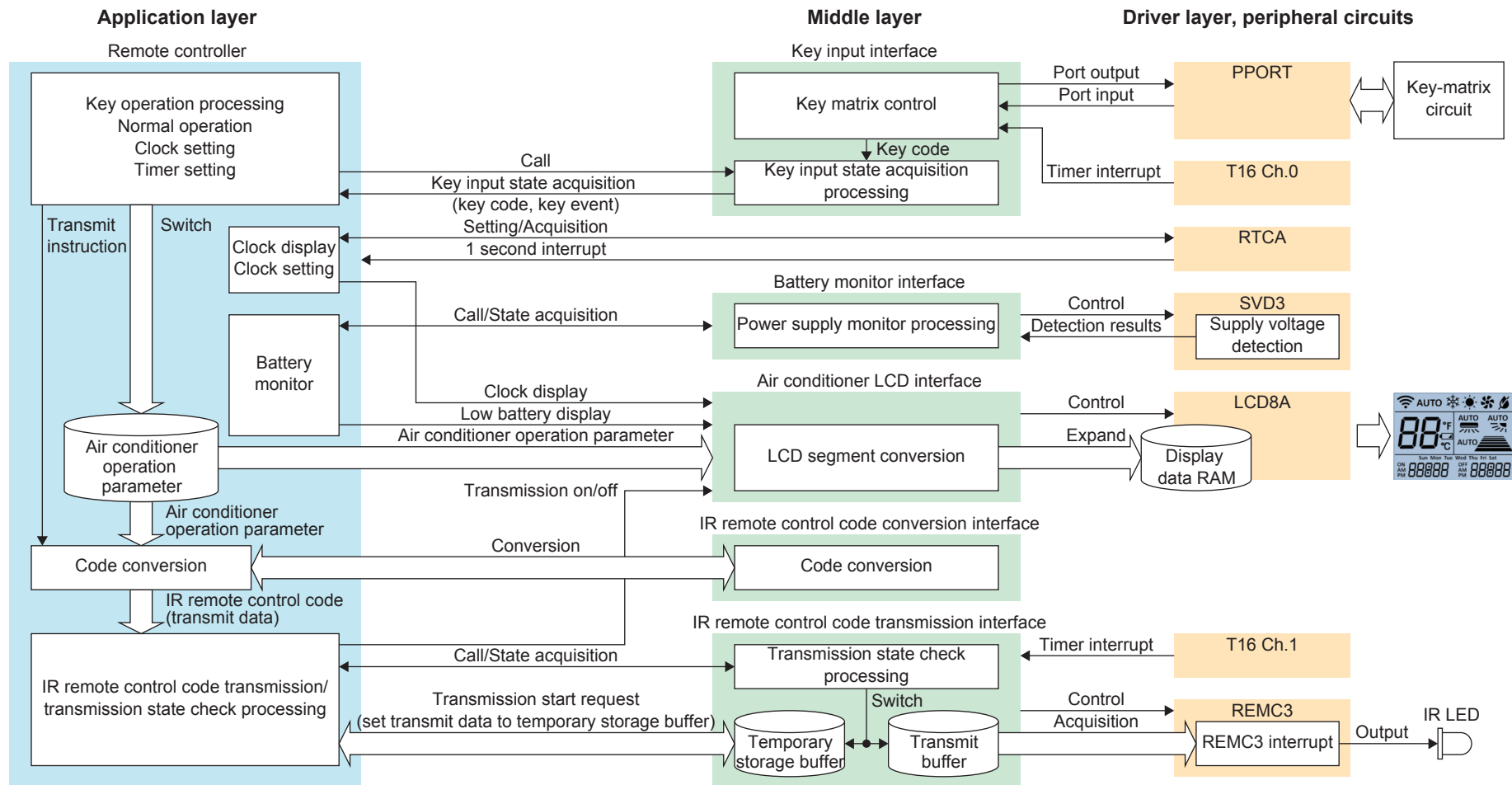

## 5. Software Description

---

### 5.3 s1c17m33\_remote\_sample\_gnu17v3

This section describes the infrared remote control software s1c17m33\_remote\_sample\_gnu17v3 that also includes demonstration and test programs.

#### 5.3.1 File Configuration (src folder)

- (1) The prefixes of the file names, main\_, mid\_, and c17, stand for application layer, middle layer, and driver layer, respectively.
- (2) The number that follows ‘\_’ at the end of the file names stand for the files that have been modified from the basic sample pack.

#### List of Files

File name	Description
main_config.h	Application configuration header file
main_acc.c	Remote controller mode program file
main_acc.h	Remote controller mode header file
main_term.c	Terminal mode program file
main_demo.c	Demonstration mode program file
main_test.c	Test mode program file
mid_key.c	Key input interface program file
mid_key.h	Key input interface header file
mid_lcdac.c	Air conditioner LDC display interface program file
mid_lcdac.h	Air conditioner LDC display interface header file
mid_accode.c	Air conditioner IR remote control code conversion interface program file
mid_accode.h	Air conditioner IR remote control code conversion interface header file
mid_remsnd.c	IR remote control code transmission interface program file
mid_remsnd.h	IR remote control code transmission interface header file
mid_remrvc.c	IR remote control code reception interface program file
mid_remrvc.h	IR remote control code reception interface header file
mid_host.c	PC communication interface program file
mid_host.h	PC communication interface header file
mid_dipsw.c	DIP switch interface program file
mid_dipsw.h	DIP switch interface header file
mid_tmr.c	Timer counter interface program file
mid_tmr.h	Timer counter interface header file
mid_bat.c	Battery level monitor interface program file
mid_bat.h	Battery level monitor interface header file
c17_init_config.h	C17 driver configuration header file
c17_clg_1.c	CLG(osc) driver program file
c17_clg.h	CLG(osc) driver header file
c17_svd3_1.c	Supply voltage detector driver program file
c17_svd3_1.h	Supply voltage detector driver header file
c17_wdt2_1.c	Watchdog timer driver program file
c17_wdt2_1.h	Watchdog timer driver header file
c17_remc3_1.c	IR remote controller driver program file
c17_remc3_1.h	IR remote controller driver header file
c17_lcd8a_1.c	LCD driver program file
c17_lcd8a_1.h	LCD driver header file
c17_rtca_1.c	Real-time clock driver program file
c17_rtca_1.h	Real-time clock driver header file
c17_port_1.c	I/O port driver program file
c17_port_1.h	I/O port driver header file

## 5. Software Description

---

File name	Description
c17_t16_1.c	16-bit timer driver program file
c17_t16_1.h	16-bit timer driver header file
c17_t16b.c	16-bit PWM timer driver program file
c17_t16b.h	16-bit PWM timer driver header file
c17_uart3_1.c	UART driver program file
c17_uart3_1.h	UART driver header file
util.c	Utility function program file
util.h	Utility function header file

### 5.3.2 File configuration (inc folder)

List of Files

File name	Description
Reg	S1C17M33 peripheral circuit registers definition file folder
c17_mcu_select.h	CPU select header file
c17m33_reg.h	S1C17M33 peripheral circuit registers definition file

## 5. Software Description

---

### 5.3.3 Module Description

This section describes the function names and their functions of the modules included in the files, mainly the functions that constitute a remote controller for an air conditioner. The public functions are prefixed with “main\_”, “mid\_”, or “c17” that represent application layer, middle layer, and driver layer, respectively.

File name: main\_acc.c

Function name	Function
main_runAcc	Main routine that executes the remote controller mode functions.
main_initAcc	Initializes the remote controller parameters.
main_onAcc	Activates the remote controller.
main_offAcc	Deactivates the remote controller.
main_execAccKeyInput	Processes key inputs from the remote controller.
main_updateClockDisp	Updates the clock displayed at the lower part of the LCD screen.

File name: main\_term.c

Function name	Function
main_runTerm	Main routine that executes the terminal mode functions.

File name: main\_demo.c

Function name	Function
main_runDemo	Main routine that executes the demonstration functions.

File name: main\_test.c

Function name	Function
main_runTest	Main routine that executes the test mode functions.

File name: mid\_key.c

Function name	Function
mid_initKey	Initializes the key input interface.
mid_startKeyScan	Starts key scan.
mid_stopKeyScan	Stops key scan.
mid_setKeyWakeup	Specifies the wakeup key, which awakes the microcontroller from SLEEP mode, and stops key scan.
mid_chkKeyWakeup	Checks whether the wakeup key specified by the mid_setKeyWakeup function was pressed or not after the microcontroller awakes from SLEEP mode. If the specified key was pressed, this function resumes key scan.
mid_pauseKeyScan	Suspends key scan and enables interrupts from all the key input ports.
mid_getKeyState	Acquires the key input state.
mid_setKeyLongPressTime	Sets the determination time for issuing a long-press event.
mid_setKeyRepeatTime	Sets the repeat event interval.
mid_cancelKeyCurKeyEvent	Cancels subsequent key events until the currently pressed key is released.

File name: mid\_lcdac.c

Function name	Function
mid_initLcdAc	Initializes the air conditioner LCD interface.
mid_onLcdAc	Activates the air conditioner LCD interface.
mid_offLcdAc	Deactivates the air conditioner LCD interface.
mid_clrLcdAc	Turns all the LCD segments off.
mid_dispLcdAcSeparator	Displays the separators on the LCD.
mid_dispLcdAcTemperature	Displays the set temperature.
mid_dispLcdAcMode	Displays the operation mode icon.
mid_dispLcdAcWindVert	Displays the vertical airflow direction icon.
mid_dispLcdAcWindHori	Displays the horizontal airflow direction icon.
mid_dispLcdAcWindFan	Displays the air volume icon.
mid_dispLcdAcBatteryLevel	Displays the battery level.
mid_dispLcdAcTransmission	Displays the transmission icon.
mid_dispLcdAcWeek	Displays the specified day-of-week icon.
mid_showLcdAcAllWeek	Turns all the day-of-week icons on.
mid_hideLcdAcAllWeek	Turns all the day-of-week icons off.
mid_dispLcdAcTime	Displays a time in "h:mm" format (BCD specification).
mid_dispLcdAcSerialTime	Displays a time in "h:mm" format (serial specification).
mid_dispLcdAcDate	Displays a date (year, month, and day) in "yyyy mm-dd" format.
mid_dispLcdAcMonthDay	Displays a month and day in "mm-dd" format.
mid_dispLcdAcYear	Displays a year in "yyyy" format.
mid_dispLcdAcClockArea	Displays a character string on the clock display portion.
mid_dispLcdAcTimerOn	Displays the ON timer icon.
mid_dispLcdAcTimerOff	Displays the OFF timer icon.
mid_dispLcdAcAmPm	Displays the AM/PM icon.
mid_dispLcdAc7Seg	Displays seven-segment patterns.
mid_selectLcdAcSegGrp	Selects the segment to be displayed in the specified segment group.
mid_setLcdAcSegGrp	Turns all the segments in the specified segment group on or off.
mid_setLcdAcSegPosition	Sets data to the segment location in the display data RAM.

File name: mid\_remsnd.c

Function name	Function
mid_initRemSnd	Initializes the IR remote control code transmission interface.
mid_onRemSnd	Activates the IR remote control code transmission interface.
mid_offRemSnd	Deactivates the IR remote control code transmission interface.
mid_reqRemSndlrSendCode	Requests the transmission of an IR remote control code.
mid_chkRemSndlrSendState	Monitors the IR remote control code transmission state.
mid_calcRemSndBcc	Calculates BCC (XOR in byte units).
mid_calcRemSndSum	Calculates the checksum in byte units.

File name: mid\_accode.c

Function name	Function
mid_initAcCode	Initializes the air conditioner IR remote control code conversion interface.
mid_convAcCode	Converts an air conditioner operation parameter into the IR remote control code.

## 5. Software Description

---

File name: mid\_remrcv.c

Function name	Function
mid_initRemRcv	Initializes the IR remote control code reception interface.
mid_onRemRcv	Activates the IR remote control code reception interface.
mid_offRemRcv	Deactivates the IR remote control code reception interface.
mid_setRemRecvFormat	Sets the data format.
mid_rcvRemRcvCode	Acquires the received IR remote control code.

File name: mid\_dipsw.c

Function name	Function
mid_initDipSw	Initializes the DIP switch input port (input with pull-up).
mid_onDipSw	Enables the DIP switch input port (input and pull-up enabled).
mid_offDipSw	Disables the DIP switch input port (set to Hi-Z).
mid_getDipSwState	Acquires the DIP switch on/off state.

File name: mid\_tmr.c

Function name	Function
mid_initTmr	Initializes the count-up timer.
mid_startTmr	Starts count-up operation of the counter specified with a number. The counter is reset to 0 before starting count up.
mid_stopTmr	Stops count-up operation of the counter specified with a number.
mid_getTmr	Acquires the count value of the counter specified with a number.

File name: mid\_bat.c

Function name	Function
mid_initBat	Initializes the battery level monitor interface.
mid_chkBatLowBattery	Checks the battery level.

### 5.3.4 Sample Program Operation Overview

#### 5.3.4.1 Function Overview

This program includes the functions to control the remote controller.

Main features:

- (1) Air conditioner operation function
- (2) Air conditioner segment LCD display function
- (3) Tact switch input function
- (4) IR remote control code transmission function
- (5) IR remote control code conversion function
- (6) Battery level monitor function

##### 5.3.4.1.1 Air Conditioner Operation Function

This function is responsible for processing normal operations, clock setting, and timer setting operations of the air conditioner remote controller. Also it transmits IR remote control codes according to the air conditioner operations.

Running/standby state	Operation mode	Description
Standby	–	Waits until the ON/OFF key is pressed.
Running	Normal operation	Processing of air conditioner body operations (body operations, IR remote control code transmission)
	Clock setting	Processing of clock setting (date and time setting for RTC)
	Timer setting	Processing of timer reservation (ON timer and OFF timer settings)

##### 5.3.4.1.2 Air Conditioner Segment LCD Display Function

This function displays the contents shown below according to the air conditioner operation.

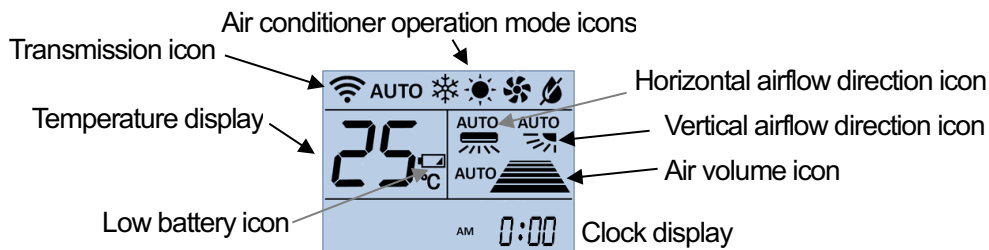

##### Clock display

The contents listed below are displayed on the clock display portion.

Operation mode	Clock display mode	Description
Normal operation	Time display	Displays the current time.
	Date display	Displays the current date for 3 seconds.
	Timer display	Displays the timer reservation settings for 3 seconds.
Clock setting	–	Blinks the setting part during clock setting.
Timer setting	–	Blinks the setting part during timer setting.

## 5. Software Description

### 5.3.4.1.3 Tact Switch (Key) Input Function

The 12 tact switches (keys) constitute a key-matrix circuit with three output ports and four input ports together. The pressed key is handled by the key input interface in the middle layer. The key input interface scans the key-matrix circuit to acquire the key input state. The key input state is represented with the key code of the pressed key and the key event according to the key state transition.

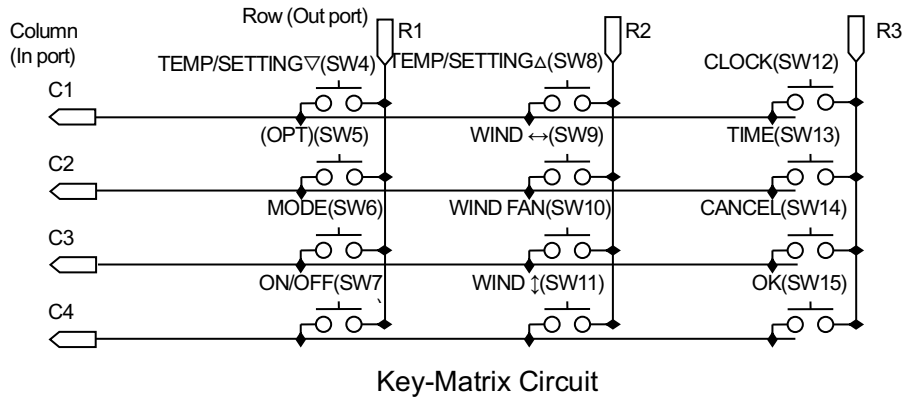

#### 5.3.4.1.3.1 Key Scan (Acquiring Key Code)

The key scan of the key-matrix circuit is performed using the timer interrupts that occur at 1 ms intervals. When a key has been pressed, the 32-bit key code is acquired. The output ports of the key-matrix circuit are represented with a symbol, R1 to R3 (key output ports), and the input ports are represented with C1 to C4 (key input ports).

Output Ports (Key Output Ports)

Symbol	PPORT
R1	P24
R2	P26
R3	P27

Input Ports (Key Input Ports)

Symbol	PPORT
C1	P21
C2	P22
C3	P23
C4	P25

- (1) A key output port, R1 first, is set to ON and other key output ports are set to OFF using a timer interrupt. The port set to ON goes an H level and the port set to OFF is configured as an input port with pull-down enabled.

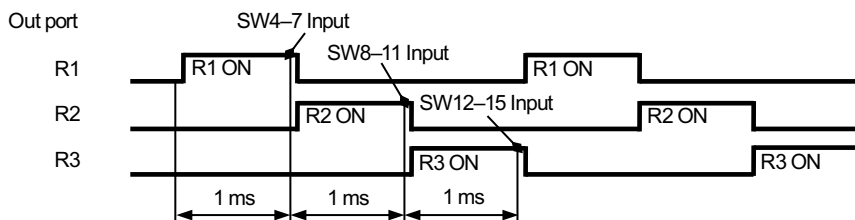

Key Output Port Settings

Output order	Key output port state		
	R1	R2	R3
1	ON (H)	OFF (Input)	OFF (Input)
2	OFF (Input)	ON (H)	OFF (Input)
3	OFF (Input)	OFF (Input)	ON (H)

- (2) The key input ports C1 to C4 are scanned using the next timer interrupt to input the state of keys connected to the key output port that has been set to ON in Step (1).  
The scanned data is used to set the key code bit corresponding to the currently activated key output port and scanned key input port as shown in the table below. The key code bit corresponding to the pressed key is set to 1. If two or more keys have been pressed, the corresponding key code bits are all set to 1.

Key input/output port	Key code			
	C1	C2	C3	C4
R1	00000001h	00000002h	00000004h	00000008h
R2	00000010h	00000020h	00000040h	00000080h
R3	00000100h	00000200h	00000400h	00000800h

- (3) Steps (1) and (2) are repeated from R1 to R3 and one key code input cycle is finished.  
(4) To avoid chattering, the key code input cycle is repeated 12 times (36 ms). If the same key code bit is set to 1 during this period, it is determined as if the key has been pressed.

5.3.4.1.3.2 Determining Key Input State Transition (Acquiring Key Event)

The figure below shows a series of key input states between pressing a key and releasing the key. When a key is pressed, the key input interface periodically checks whether the key input state is changed or not and notifies the high-order application program of the results until the key is released. A key input state transition issues a key event as shown in the figure below.

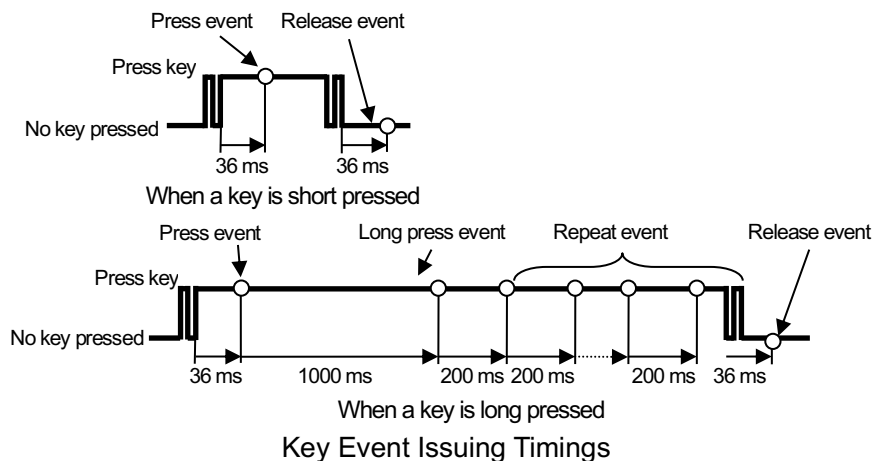

- (1) If there is no pressed key, no key event issues. Also there is no key input state transition, no key event issues until the next key event factor occurs even if a key has been pressed continuously from the previous issued key event.
- (2) Pressing a key issues a key press event. When a key code bit, which is acquired through the key scan, is set to 1, the key input interface determines that the key has been pressed. A key press event is issued about 30 to 40 ms after a key is pressed as the chattering elimination processing is executed during key scan.
- (3) A long press event is issued when the key is pressed and held about 1 second after a key press event is issued. The long press event determination time from a key press event can be changed dynamically in the program.
- (4) If the pressed key is being held after a long press event is issued, a repeat event is issued at 200 ms intervals. The repeat determination time can be changed dynamically in the program.
- (5) A press limit event is issued when the key is pressed and held about 10 seconds after a key press event is issued.
- (6) A release event is issued when the pressed key is released or when another key is pressed before releasing the key currently being pressed. A release event is issued about 30 to 40 ms after a key is released as the chattering elimination processing is executed.

## 5. Software Description

### 5.3.4.1.3.3 Acquiring Key Input State

The key input state can be acquired using the key event acquiring function (`mid_keyGetState`) implemented in the key input interface. The key code (currently pressed key) and key event (key input state transition) are returned from the function as the key input state.

The key code consists of 32 bits in which each bit is allocated to a particular key. When a key is pressed, the corresponding bit is set to 1. If two or more keys are pressed simultaneously, the corresponding plural bits are set to 1.

Key event means a change of the key input state.

The table below lists the key codes used in this program and the key event definitions.

Key Code Table

Key code	Switch number	Switch name	Definition
00000000h	—	No pressed key	KEY_NONE
00000001h	SW4	TEMP/SETTING▽	KEY_TEMP_UP KEY_SETTING_UP
00000002h	SW5	OPT	KEY_OPT
00000004h	SW6	MODE	KEY_MODE
00000008h	SW7	ON/OFF	KEY_ONOFF
00000010h	SW8	TEMP/SETTING△	KEY_TEMP_DN KEY_SETTING_DN
00000020h	SW9	WIND ↔	KEY_WIND_HORI
00000040h	SW10	WIND FAN	KEY_WIND_FAN
00000080h	SW11	WIND ↓	KEY_WIND_VERT
00000100h	SW12	CLOCK	KEY_CLOCK
00000200h	SW13	TIME	KEY_TIME
00000400h	SW14	CANCEL	KEY_CANCEL
00000800h	SW15	OK	KEY_OK

Key Event Table

Event name	Definition	Issuing timing
None	KEY_EVENT_NO	There is no pressed key or no key input state transition. Even if a key is being pressed continuously after an event is issued, no key event is issued until the next key event factor occurs.
Press	KEY_EVENT_PRESS	Issued when a key is pressed.
Release	KEY_EVENT_RELEASE	Issued when a pressed key is released.
Long press	KEY_EVENT_LONG_PRESS	Issued when the same key is pressed continuously for 1 second (*1) after a press event is issued.
Repeat	KEY_EVENT_REPEAT	Issued at 200 ms intervals (*2) while the same key is being pressed after a long press event is issued.
Press limit	KEY_EVENT_PRESS_LIMIT	Issued when the same key is pressed continuously for 10 seconds or more after a press event is issued.

\*1: Can be changed using the `mid_setKeyLongPressTime` function.

\*2: Can be changed using the `mid_setKeyRepeatTime` function.

## 5.3.4.1.3.4 Operation of Key Input Interface

The following describes the operation flow of the key input interface:

(1) First, the key input interface is initialized and activated.

- T16 Ch.0 is set to generate 1 ms timer interrupts for key scan and its clock source is set to OSC1.

Clock source	OSC1
Division ratio	1/1
Reload value	32

- The key input ports C1 to C4 are configured as an input port with the pull-down resistor enabled.
- The key output ports R1 to R3 are configured as an input port with the pull-down resistor enabled.

(2) A key scan is started.

Before starting a key scan, the key output ports are initialized and the timer for key scan is started.

- The key scan output ports R1 to R3 are initialized.  
The key scan output order is reset to 1.

Key Output Port Setting

Output order	Key port output		
	R1	R2	R3
1	ON (H)	OFF (Input)	OFF (Input)

- The parameters are initialized.  
The current key code is set to KEY\_NONE and the key event is set to KEY\_\_EVENT\_NONE.
- T16 Ch.0 is started and its interrupts are enabled.

(3) By registering a wakeup key, such as the ON/OFF key, to the key input interface, an input interrupt of the wakeup key port can be used to awake the microcontroller from SLEEP mode.

The wakeup key setting function (`mid_setKeyWakeup`) is used for this registration. When the microcontroller enters SLEEP mode after the `mid_setKeyWakeup` function is called with a key code (e.g., KEY\_ONOFF) specified, the microcontroller will awake by pressing the specified key. After wakeup, the `mid_chkKeyWakeup` function can be used to check whether the wakeup key was pressed or not. If the microcontroller has awoken by the wakeup key, the key input interface resumes the key scan.

(4) If no other processing is required during key scan, the microcontroller can be placed into a standby mode until an interrupt occurs.

Interrupt sources

- T16 Ch.0 1 ms interval interrupt (generated while the key scan is underway)  
T16 Ch.0 generates interrupt at 1 ms intervals during key scan.
- Port input interrupt (generated while the key scan is suspended)  
The key scan (T16 Ch.0) is suspended if no key is pressed for 5 seconds.  
While the key scan is suspended, C1 to C4 input port interrupts are enabled.

(5) A high-order application calls the key input state acquisition function (`mid_getKeyState`) to acquire the key (key code) that has been pressed and the key input state transition (key event).

(6) A high-order application performs the processing according to the acquired key code and key event.

The following shows the flowcharts:

## 5. Software Description

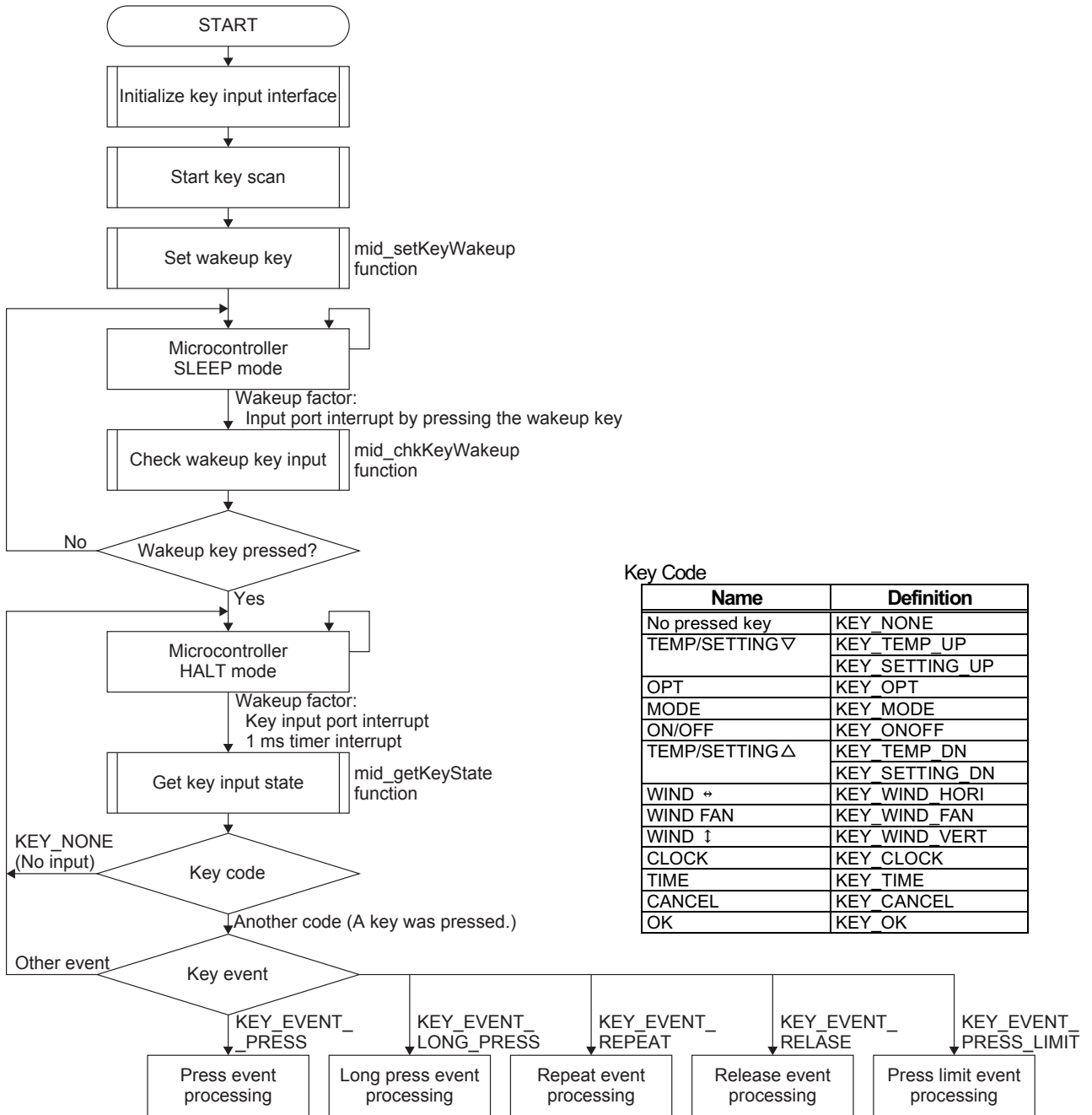

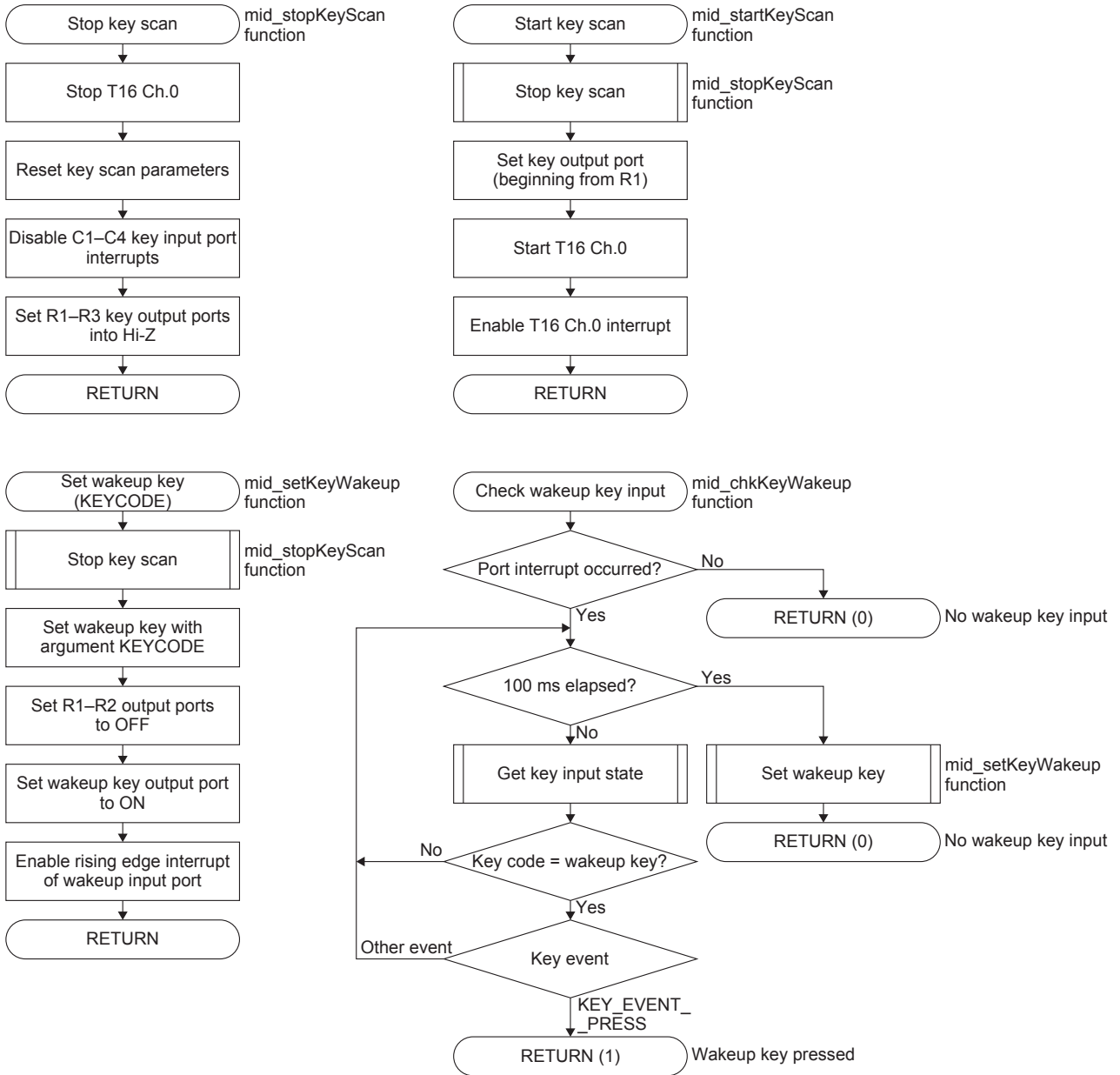

## 5. Software Description

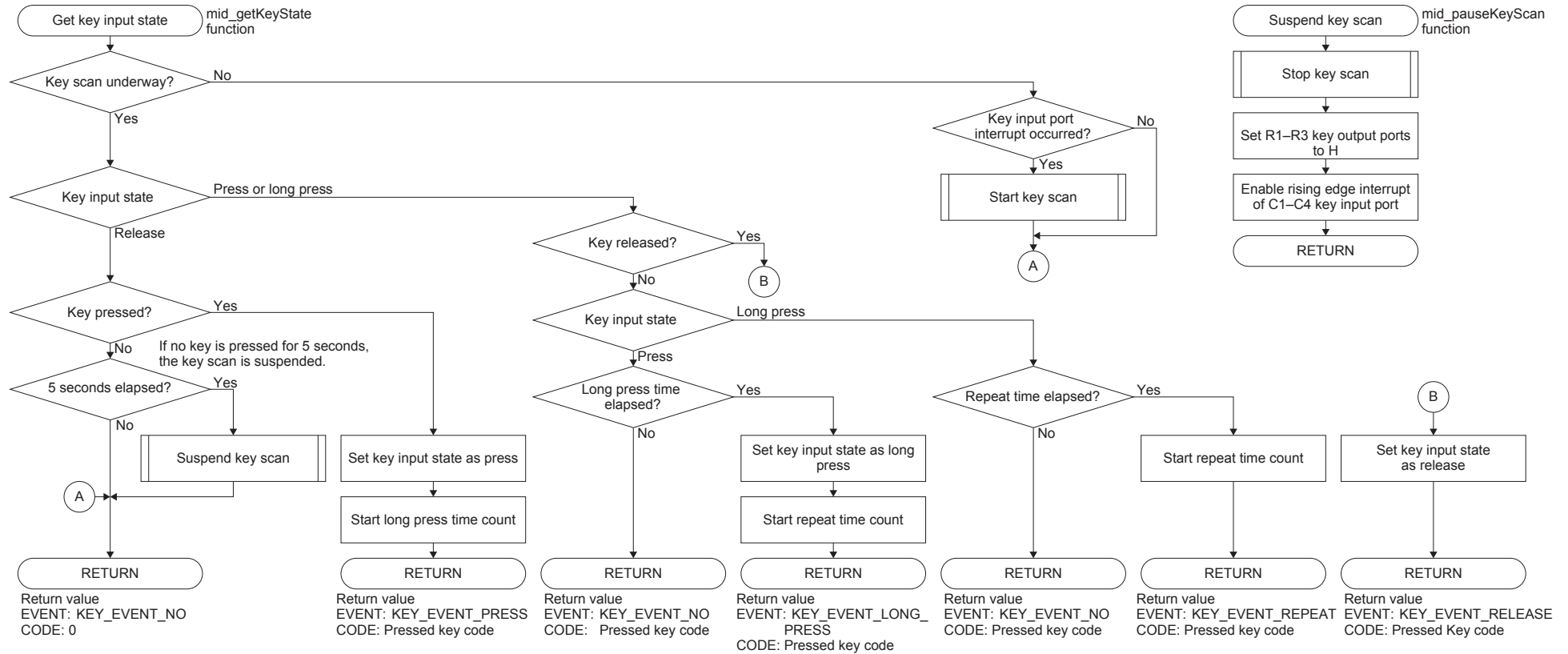

## 5.3.4.1.4 IR Remote Control Code Transmission Function

The IR remote control code transmission interface controls a peripheral circuit driver (c17 REMC3 driver) for the IR remote controller (REMC3) to transmit IR remote control codes.

## 5.3.4.1.4.1 IR Remote Control Code Transmission Method

The IR remote control code transmission interface performs transmission processing of IR remote control code data at the high-order application's request.

The high-order application issues a request to transmit IR remote control code data using the transmission request function (`mid_reqRemSndIrSendCoode`) and checks the transmission state using the transmission check function (`mid_chkRemSndIrSendState`).

The data passed through the transmission request function is saved into a buffer for transmission once and then it is transmitted using a REMC3 interrupt. The transmission check function checks that the REMC3 interrupt processing has completed and inserts a blank period before transmitting the next IR remote control code to satisfy the minimum transmission interval. The high-order application must call the transmission check function periodically after calling the transmission request function until the transmission is completed.

A RAM area is allocated for two buffers for transmission to accept the next transmission request even when data is being transmitted.

The figure below shows a transmission sequence of the IR remote control code interface.

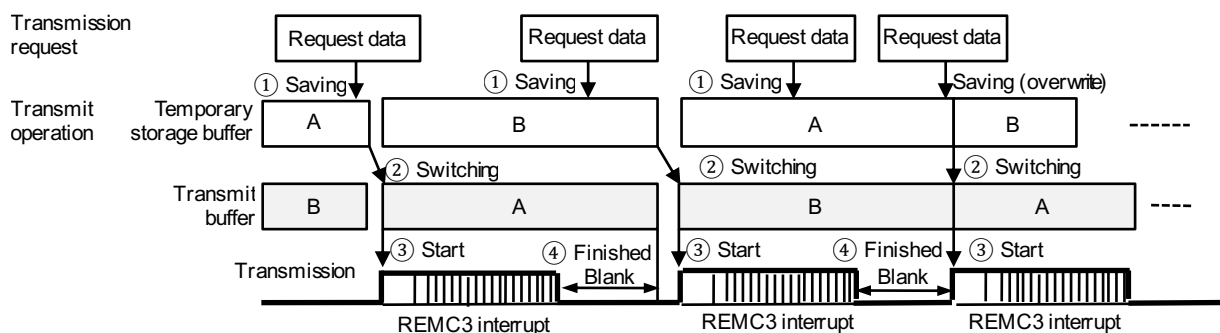

IR Remote Control Code Transmission Sequence

- ① The IR remote control code interface receives IR remote control code data from the high-order application. Two buffers are allocated in the RAM and they work as a transmit buffer and a temporary storage buffer by switching alternately. The received data is loaded in the temporary storage buffer and the buffer goes into full state. If the temporary storage buffer is already in full state when data is received, the buffer is overwritten with the new data.
- ② When the temporary storage buffer goes into full state while the transmit buffer is in empty state, the temporary storage buffer is switched to transmit buffer. When the buffer function is switched, the transmit buffer goes into full state and the temporary storage buffer goes into empty state.
- ③ When the transmit buffer goes into full state, a transmission starts. Data transmission is processed in the REMC3 interrupt handler.
- ④ When the data transmission using a REM3 interrupt has completed, the transmit operation enters waiting state for the blank period. After the blank period has elapsed, one transmission operation is completed and the transmit buffer goes into empty state.

## 5. Software Description

---

### 5.3.4.1.4.2 Operation of IR Remote Control Code Transmission Interface

The following describes the operation flow of the IR remote control code transmission:

(1) The IR remote control code transmission interface is initialized.

- The initialization function (`c17initRemc`) is called to initialize the C17 REMC3 driver and the transmission format is configured.

Format	AEHA *
Sub-carrier frequency	36.7 kHz $\pm$ 2% duty 1/3

\* The NEC or SONY format can also be specified by changing the setting in the source code.

- The timer that is used to check the IR remote control code transmission state is initialized

T16 Ch.1 is configured to generate interrupts at 1 ms interval.

Clock source	OSC1
Division ratio	1/1
Reload value	32

(2) The high-order application program activates the IR remote control code transmission interface. At this time, the following processing is performed to start operation of the peripheral circuit REMC3:

- REMC3 is enabled using the `c17enableRemc` function of the C17 REMC3 driver.
- REMC3 interrupts are enabled using the `c17enableIntRemc` function of the C17 REMC3 driver.

(3) The high-order application program calls the IR remote control code transmission request function (`mid_reqRemSndIrSendCoode`) to request a transmission of an IR remote control code.

- The IR remote control transmission request function puts the transmit data specified through the argument into the temporary storage buffer when being called. When the data is loaded to the temporary storage buffer, the buffer goes into full state. If the temporary storage buffer is already in full state, it is overwritten.
- If the transmit buffer is in empty state, the buffer function is switched between the temporary storage buffer and the transmit buffer, and a transmission starts.

(4) The high-order application program calls the IR remote control code transmission check function (`mid_chkRemSndIrSendState`) to check the transmission state.

The transmission check function performs the processing shown below and returns a return value that indicates whether a transmission request has been issued or not. When either the transmit buffer or the temporary storage buffer is in full state, the function returns “transmission request has been issued.” The high-order application program must call the transmission check function periodically until “no transmission request has been issued” is returned.

- When the transmit buffer is in full state, the transmission check function checks if a transmission from the transmit buffer has completed. A transmission of the transmit buffer data is completed when the blank period has elapsed after the data is transmitted by a REMC3 interrupt. The transmit buffer goes into empty state upon completion of the transmission.
- If the temporary storage buffer is in full state when the transmission of the transmit buffer data has completed, the buffer function is switched between the transmit buffer and the temporary storage buffer, and the next data transmission starts.

(5) The high-order application program deactivates the IR remote control code transmission interface. REMC3 stops operating after the transmission of the transmit buffer data has completed.

- When transmit data remains in the transmit buffer or temporary storage buffer, the IR remote control code transmission interface waits for completion of the transmission.
- REMC3 is disabled by the `c17disableRemc` function of the C17 REMC3 driver.

The following shows the flowcharts:

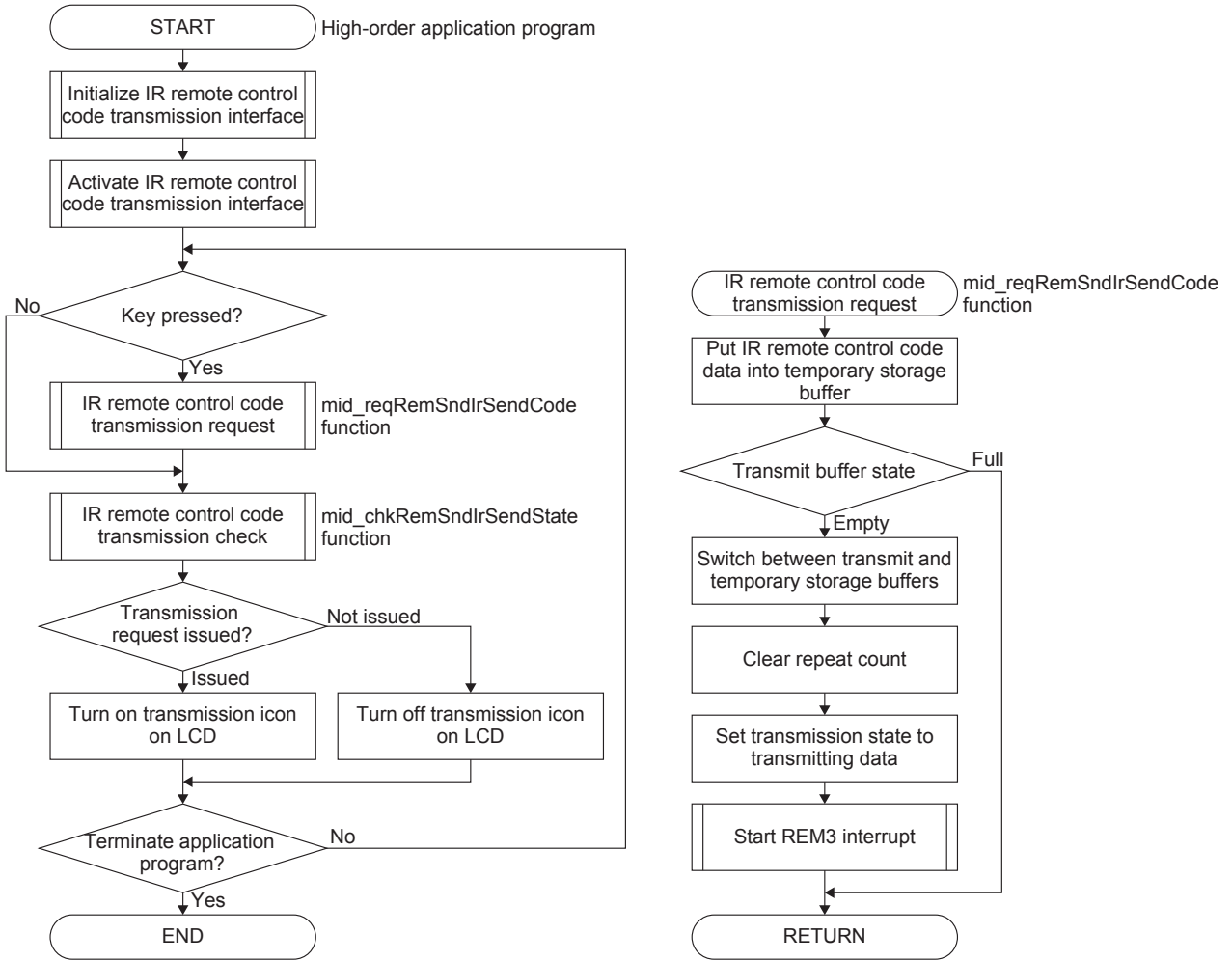

## 5. Software Description

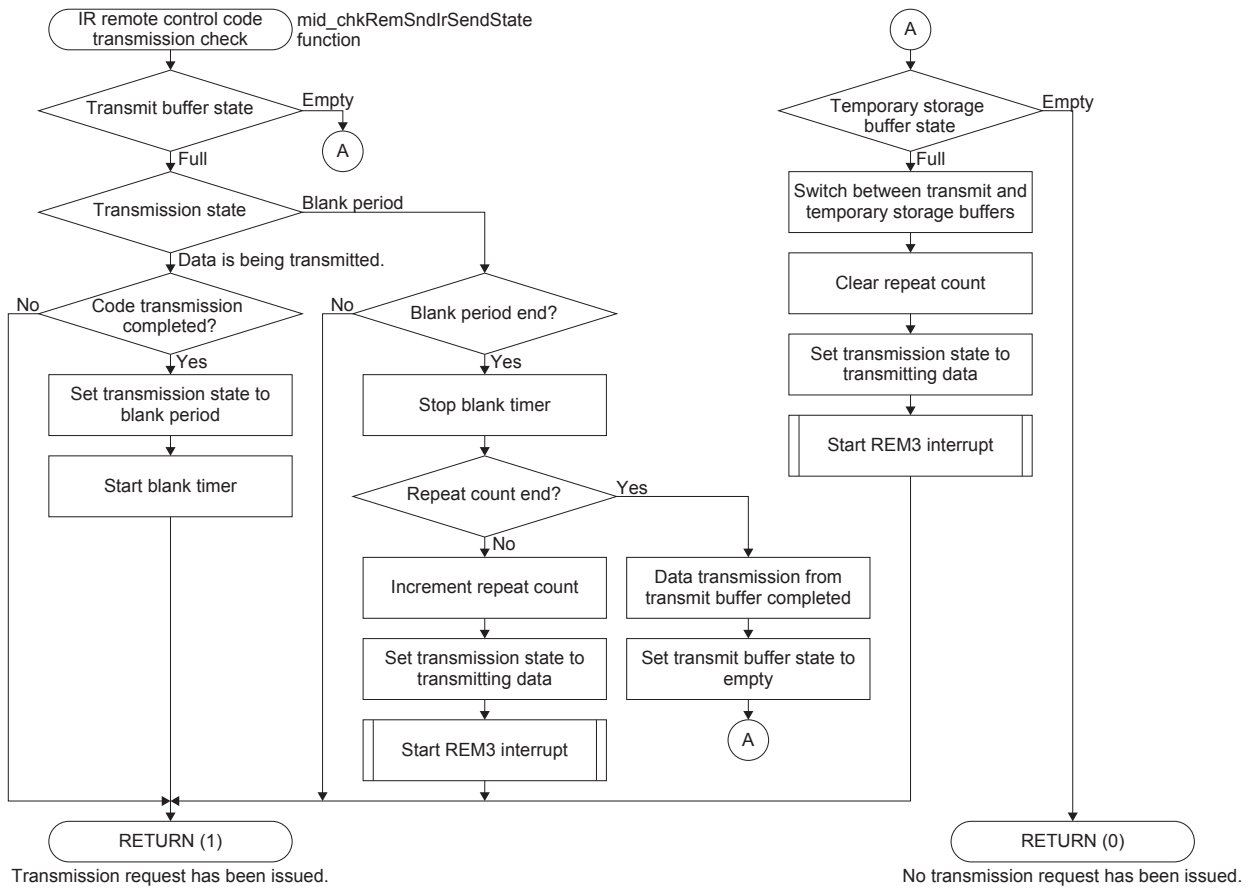

5.3.4.1.5 IR Remote Control Code Conversion Function

This program has the function to convert general-purpose air conditioner operation parameters into each of the manufacturer-specific IR remote control codes. The air conditioner operation parameter is determined when a key is pressed and is converted into the transmit parameter (IR remote control code) at transmitting.

By changing the conversion processing in the air conditioner IR remote control code conversion interface, various remote controllers can be supported.

The air conditioner operation parameters are stored in the ACC\_AC\_SETTINGS\_S structure and the transmit parameters are stored in the REMAC\_IRCODE\_S union.

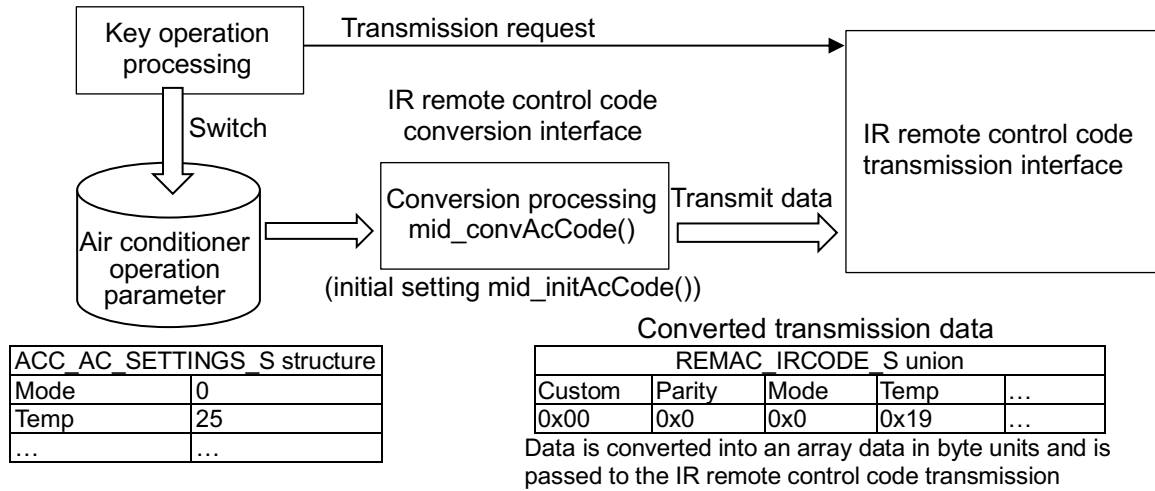

ACC\_AC\_SETTINGS\_S structure

```
typedef struct acc_ac_settings_s
{
    unsigned short    AcOnOff;    //Power ON/OFF
    unsigned short    TempUnit;   //Temperature unit
    unsigned short    Temp;       //Set temperature
    unsigned short    Mode;       //Operation mode
    unsigned short    WindVert;   //Vertical airflow direction
    unsigned short    WindHori;   //Horizontal airflow direction
    unsigned short    WindFan;    //Air volume
    ACC_TIMER_S       OnTimer;    //On timer information
    ACC_TIMER_S       OffTimer;   //OFF timer information
}ACC_AC_SETTINGS_S;
```

REMAC\_IRCODE\_S union

```
typedef union remac_icode_s
{
    unsigned char code[N];
    struct {
        unsigned char Custom;
        unsigned char Parity:4;
        unsigned char Mode:4;
        unsigned char Temp;
        .....
    }field;
}REMAC_IRCODE_S;
```

## 5. Software Description

---

### 5.3.4.1.5.1 Example to Change Conversion Processing

- (1) Edit the REMAC\_IRCODE\_S union members according to the IR remote control code data structure.

```
typedef union remac_ircode_s
{
    unsigned char code[7];
    struct {
        unsigned char CostomCodeH;
        unsigned char CustomCodeL;
        unsigned char Parity:4;
        unsigned char OnOff:4;
        unsigned char tempriture;
        unsigned char Mode:4;
        unsigned char windHori:4;
        unsigned char windVert:4;
        unsigned char windFan:4;
        unsigned char bcc;
    }field;
}REMAC_IRCODE_S;
```

- (2) Describe the conversion processing in the conversion function mid\_convAcCode.

Prototype for conversion function

```
void mid_convAcCode(REMAC_IRCODE_S *pIrCode, const ACC_AC_SETTINGS_S *pAcSettings)
```

Example of conversion processing

Copy the contents of the ACC\_AC\_SETTINGS\_S structure to a REMAC\_IRCODE\_S union variable.

```
pIrCode->CostomCodeH    = 0x00;
pIrCode->CustomCodeL    = 0x00;
pIrCode->OnOff          = pAcSettings->AcOnOff;
pIrCode->tempriture     = pAcSettings->Temp;
pIrCode->windFan        = pAcSettings->WindFan;
```

### 5.3.4.1.5.2 Conversion/Transmission Procedure

Follow the procedure below to convert the air conditioner parameter into the IR remote control code.

- (1) Declare an ACC\_AC\_SETTINGS\_S structure variable for the air conditioner operation parameters and a REMAC\_IRCODE\_S union variable for the IR remote control codes.
- (2) Initialize the declared variables as necessary.  
The initial setting processing for the IR remote control code union should be implemented in the mid\_initAcCode function.
- (3) When a key is pressed, change the parameter in the ACC\_AC\_SETTINGS\_S structure according to the key operation.
- (4) Convert the key operation parameter into the IR remote control code.

The following shows a coding example:

```
#define ACC_IR_REPEAT_COUNT 1
// global variable
REMAC_IRCODE_S AccIrCode; //For IR remotecontrol code.
ACC_AC_SETTINGS_S AccAcSettings; //For A/C operation.

void main(void)
{
    // Initialize the IR remote control code transmit interface.
    mid_initRemSnd();

    // Initialize the IR remote control code converting interface.
    mid_initAcCode(&AccIrCode);

    // Initialize the key operation parameters.
    AccAcSettings.Mode = 0;
    ....

    while(1)
    {
        // Check key input state.
        if ( MODE key is pushed )
        {
            // Switch the operation mode on key operation parameter.
            if (++AccAcSettings.Mode >= 6)
            {
                AccAcSettings.Mode = 0;
            }

            // Convert A/C settings to IR remote control code.
            mid_convAcCode(&AccIrCode, &AccAcSettings);

            // Request to send.
            mid_reqRemSndIrSendCode(
                ACC_IR_REPEAT_COUNT, AccIrCode.code, sizeof(AccIrCode.code));
        }

        // Check sending progress of IR remote control code.
        mid_chkRemSndIrSendState();
    }
}
```

## 5. Software Description

### 5.3.4.1.6 Battery Level Monitor

The battery level is monitored by the battery level monitor interface. The battery level monitor interface monitors the power supply voltage using the supply voltage detector (SVD3) and notifies the high-order application program of the detected battery level. Also it performs the reset processing when the battery is replaced.

#### 5.3.4.1.6.1 Battery Level Detection Method

The battery level monitor interface activates SVD3 for 2 ms at 1 second intervals to monitor the power supply voltage and determines the battery condition from change of the power supply voltage.

- (1) First, the SVD detection level is set to 2.2 V and the power supply voltage is compared with it. If voltage drop state is detected twice continuously, it is regarded as a low battery level.
- (2) When a low battery level is detected, SVD detection level is set to 2.5 V to detect if the power supply voltage is restored.
- (3) If a 2.5 V or more voltage is detected twice continuously before the power supply voltage drops under the brownout detection voltage (BOR), it is regarded as if the battery has been replaced, and a reset is issued to the microcontroller.

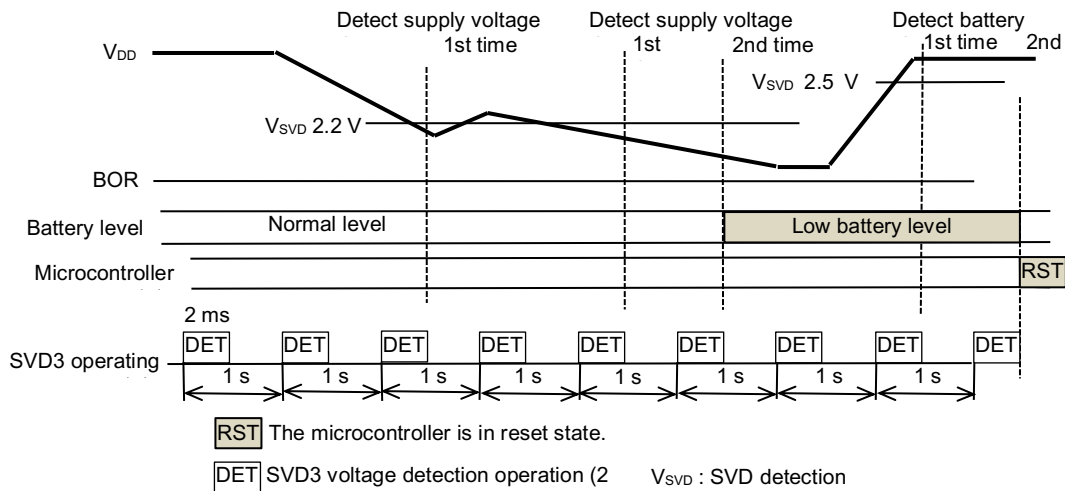

#### 5.3.4.1.6.2 Operation of Battery Level Monitor Interface

The following describes the operation flow of the battery level monitor:

- (1) The battery level monitor interface is initialized.  
SVD3 is configured with 2.2 V SVD detection level and continuous operating mode.
- (2) The battery level check function (`mid_chkBatLowBattery`) is periodically called to monitor the battery level. It performs the following processing:
  - The SVD detection and 1 ms timer operations are started when a 1 second RTC interrupt occurs.
  - When 2 ms has elapsed from start of the SVD detection operation, the `SVDINTF.SVDDT` bit is read to acquire the power supply voltage condition.
  - When the battery level is normal, the SVD detection level is set to 2.2 V to detect drop of the battery level.
  - If the battery level is detected as less than 2.2 V twice continuously, it is regarded as if the battery voltage has dropped to a low battery level.
  - When the power supply voltage is detected as a low battery level, the SVD detection level is set to 2.5 V to detect restoration of power supply voltage.
  - If the battery level is detected as 2.5 V or more twice continuously after a low battery level is detected, it is regarded as if the battery has been replaced. In this case, a reset is issued to the microcontroller.

The following shows the flowcharts:

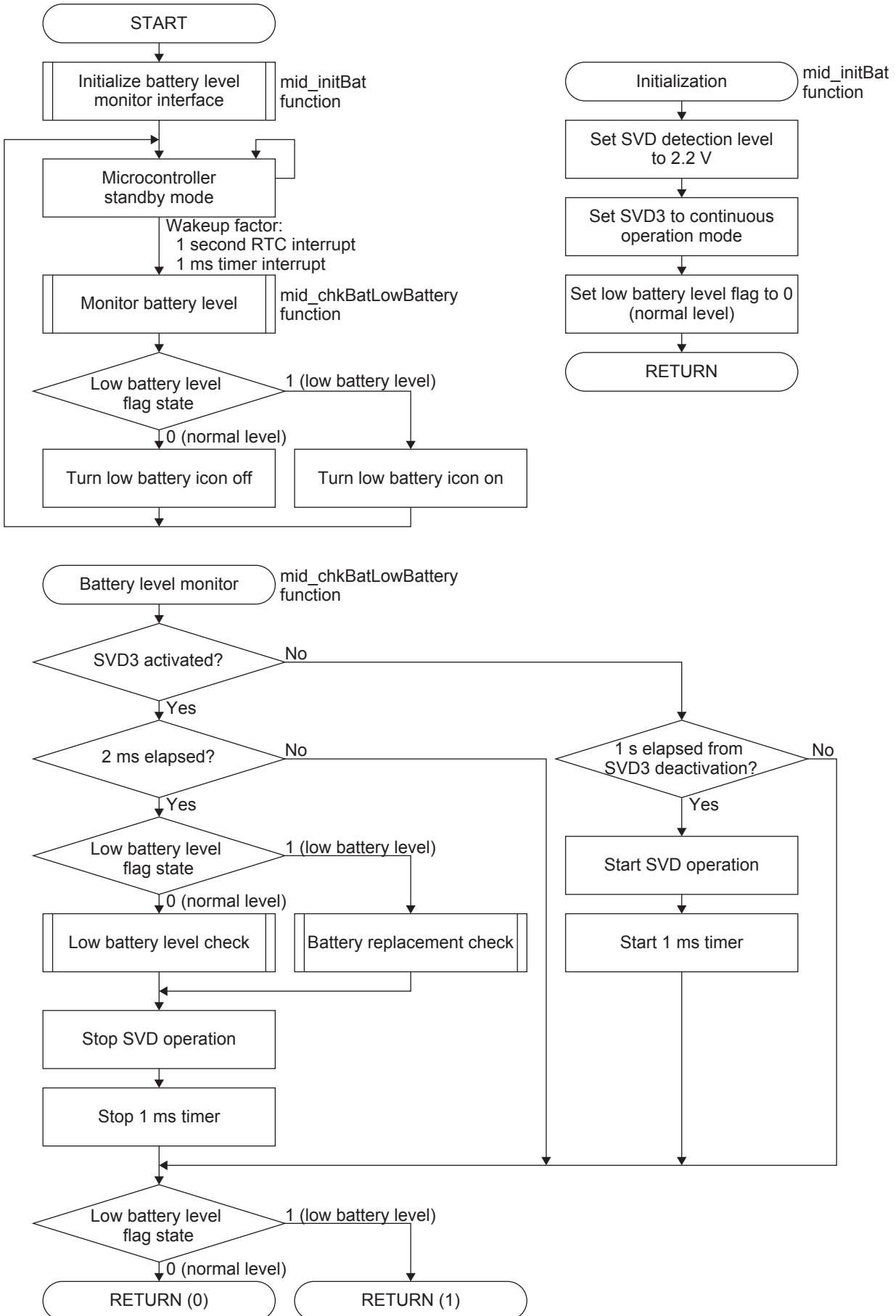

## 5. Software Description

---

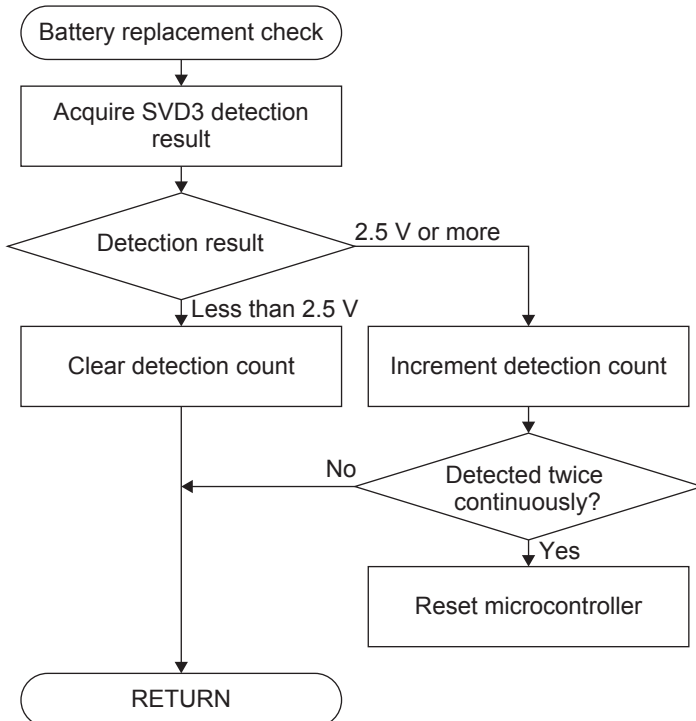
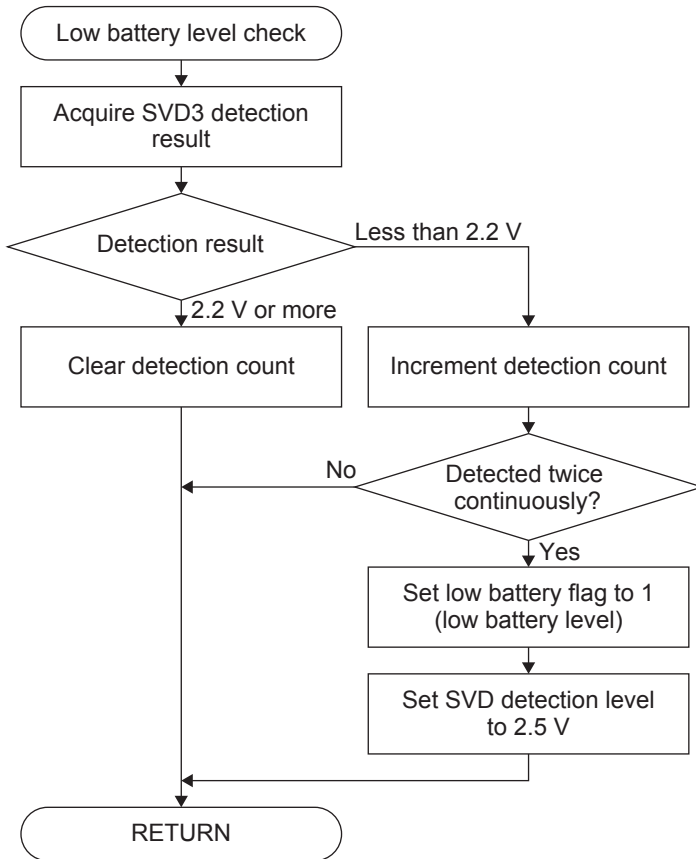

### 5.3.4.2 Configuration of Application Program

The “src\main\_config.h” file is used for configuration to build this program.

#### Main Configuration Items

Item	Definition name	Meaning
Application features	MAIN_USE_DEMO_MODE	Enable/disable demonstration mode
	MAIN_USE_TERM_MODE	Enable/disable terminal mode
	MAIN_USE_TEST_MODE	Enable/disable test mode
Time display on the remote controller during standby	ACC_ALWAYS_CLOCK_DSIP	Enable/disable the time display
Temperature settings	ACC_TEMP_UNIT	Unit of temperature display
	ACC_TEMP_MAX	Upper limit of temperature adjustment (Celsius unit)
	ACC_TEMP_MIN	Lower limit of temperature adjustment (Celsius unit)
	ACC_TEMP_DEF	Initial value of set temperature
IR remote control code settings	IRCODE_LENGTH_MAX	Maximum transmit data length
	REMSND_CODE_TR_BLANK	Minimum blank period length in transmission (equivalent to AEHA trailer part)

#### 5.3.4.2.1 Configuration Examples

(1) Enable/disable the application features

Each application feature can be disabled (not including ones from the targets to build) by commenting the definitions shown below out.

```
#define MAIN_USE_DEMO_MODE
#define MAIN_USE_TERM_MODE
#define MAIN_USE_TEST_MODE
```

Definition	Meaning
MAIN_USE_DEMO_MODE	Enable/disable demonstration mode
MAIN_USE_TERM_MODE	Enable/disable terminal mode
MAIN_USE_TEST_MODE	Enable/disable test mode(*1)

\*1 When enabling test mode, terminal mode must also be enabled.

Example:

To disable demonstration mode and test mode

```
##define MAIN_USE_DEMO_MODE
#define MAIN_USE_TERM_MODE
##define MAIN_USE_TEST_MODE
```

(2) Enabling the time display on the remote controller during standby (when the LCD is off)

By editing the definition value of “#define ACC\_ALWAYS\_CLOCK\_DSIP” as “ACC\_ALWAYS\_CLOCL\_DISP\_ENABLE (1),” the clock display is enabled even when the remote controller is in standby state.

To disable clock display

```
#define ACC_ALWAYS_CLOCK_DSIP ACC_ALWAYS_CLOCL_DISP_DISABLE
```

To enable clock display

```
#define ACC_ALWAYS_CLOCK_DSIP ACC_ALWAYS_CLOCL_DISP_ENABLE
```

## 5. Software Description

---

(3) Setting temperature display conditions

Edit the definition “#define ACC\_TEMP\_UNIT” to select the unit used for temperature display from Celsius and Fahrenheit.

Display in Celsius

```
#define ACC_TEMP_UNIT ACC_TEMP_UNIT_CELSIUS
```

Display in Fahrenheit

```
#define ACC_TEMP_UNIT ACC_TEMP_UNIT_FAHRENHEIT
```

The temperature adjustment range should be specified in Celsius regardless of the unit selection.

```
#define ACC_TEMP_MAX 32 // Maximum temperature.
```

```
#define ACC_TEMP_MIN 16 // Minimum temperature.
```

```
#define ACC_TEMP_DEF 25 // Default temperature.
```

The following shows the temperature display on the LCD when the temperature adjustment range is defined as above.

Celsius	Fahrenheit	Celsius	Fahrenheit	Celsius	Fahrenheit	Celsius	Fahrenheit	Celsius	Fahrenheit
16°C	61°F	20°C	68°F	24°C	75°F	28°C	82°F	32°C	90°F
17°C	63°F	21°C	70°F	25°C	77°F	29°C	84°F		
18°C	64°F	22°C	72°F	26°C	79°F	30°C	86°F		
19°C	66°F	23°C	73°F	27°C	81°F	31°C	88°F		

5.3.4.3 Microcontroller Boot Processing

(1) When reset state is canceled after turning the microcontroller on, the CPU core and peripheral functions are initialized.

- The system clock is switched from IOSC to OSC3 (12 MHz internal oscillator).
- The OSC1 oscillator circuit is configured to crystal oscillator (32.768 kHz).
- The watchdog timer is configured.
- The battery level monitor interface is initialized.
- RTC is initialized with date/time set to 2018/1/1 00:00:00.
- 1 second RTC interrupts are enabled.
- The LCD interface is initialized.
- The DIP switch input ports are initialized and the set state is read.

(2) When the initialization is completed, the function that is specified with the DIP switch is called.

The following shows the flowchart:

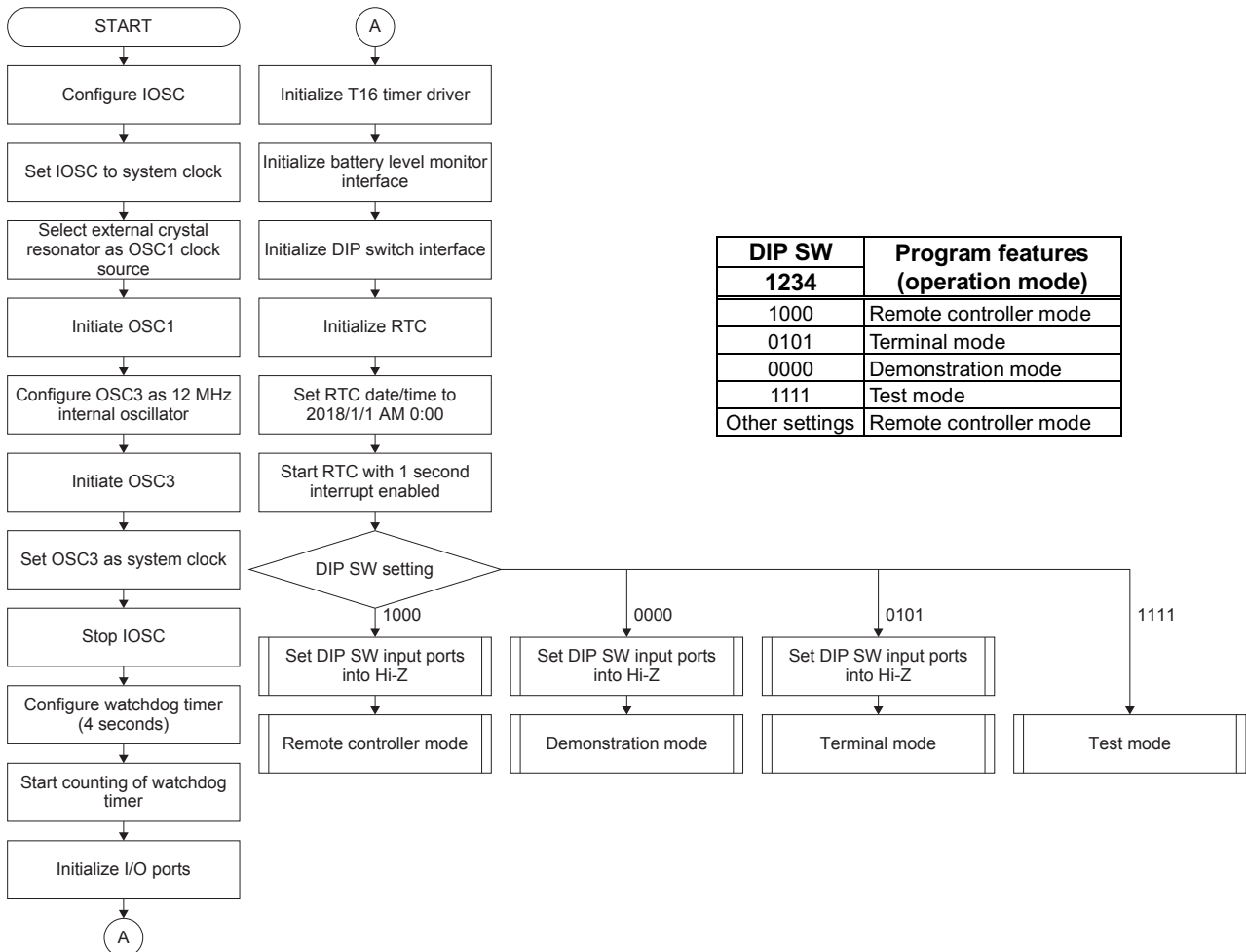

## 5. Software Description

---

### 5.3.4.4 Processing in Remote Controller Mode

The reference board set in remote controller mode works as a remote controller for an air conditioner.

- (1) When the program starts, the parameters and peripheral interfaces are initialized and then the remote controller is put into standby state.

The following lists the initialization processing performed at this time:

- The key input interface is initialized.
- The IR remote control code transmission interface is initialized.
- The air conditioner LCD interface is initialized.
- The air conditioner operation parameters are initialized.

#### List of Air Conditioner Operation Parameters

Item	Setting contents/range	Initial value	Application	
Operation mode setting	AUTO, Cool, Heat, Fan, Dry	AUTO	Normal operation	
Temperature setting	16°C to 32°C	25°C		
Vertical airflow direction setting	AUTO, 5 steps in vertical direction	AUTO		
Horizontal airflow direction setting	AUTO, 5 steps in horizontal direction	AUTO		
Air volume setting	AUTO, 5 air volume levels	AUTO		
On timer setting	Enable/disable	Enable, disable	Timer setting operation	
	ON time	0:00 to 23:59		0:00 (AM)
Off timer setting	Enable/disable	Enable, disable		Disabled
	OFF time	0:00 to 23:59		0:00 (AM)

- (2) When the remote controller enters standby state, the LCD is turned off, the clocks except OSC1 (32.768 kHz) are stopped, and the microcontroller is placed into SLEEP mode.

While the remote controller is in standby state, a 1 second RTC interrupt or an ON/OFF key input port interrupt temporarily awake the microcontroller from SLEEP mode to perform the following processing:

- When a 1 second RTC interrupt occurs  
After performing the processing shown below, the microcontroller enters SLEEP mode again.
  - Resetting the watchdog timer  
To provide against runaway due to an electrostatic discharge (ESD) or other condition, the watchdog timer is kept running even if the microcontroller is in SLEEP mode.
  - Monitoring the battery level  
If once the supply voltage drops under 2.2 V of low battery level and then is restored to a 2.5 V or higher voltage, the microcontroller is reset assuming that the battery has been replaced.
  - Updating the clock display (when always clock display mode is enabled)
- When an ON/OFF key input port interrupt occurs  
Pressing the ON/OFF key puts the remote controller into operating state.

- (3) When a key input or interrupt occurs while the remote controller is in operating state, it initiates the remote controller operation processing shown below.
- Processing when the remote controller starts operating  
The remote controller activates in normal operation mode and transmits an IR remote control code to turn the air conditioner on.
    - The remote controller always activates in normal operation mode even if the air conditioner was turned off during clock setting or timer setting.
    - The previous air conditioner operation parameter settings are retained
  - Resetting the watchdog timer  
The watchdog timer is reset periodically.
  - Key input processing  
Depending on the key input state acquired through the key input interface, processing of normal operation mode, clock setting mode, or timer setting mode is performed.
  - Updating the clock display  
The clock display at the lower part of the LCD is updated.
  - Monitoring the IR remote control code transmission  
The IR remote control code transmission state is monitored.
  - Monitoring the battery level  
When the power supply voltage is detected as a 2.2 V or lower voltage, the low battery level icon is displayed on the LCD. When the power supply voltage is restored from a low battery level to a 2.5 V or higher voltage, the microcontroller is reset assuming that the battery has been replaced. While the infrared LED is being lit, current consumption increases and it causes the power supply voltage to drop temporarily. Therefore the battery level monitor operation is temporarily suspended during transmitting IR remote control code.
  - Saving power  
When there is no processing required to execute, the microcontroller is placed into HALT mode even if the remote controller is in operating state.
- (4) When the ON/OFF key is pressed while the remote controller is in operating state, an IR remote control code for power off is transmitted to the air conditioner even if the air conditioner is off and then the remote controller is placed into standby state.

The following shows the flowchart:

## 5. Software Description

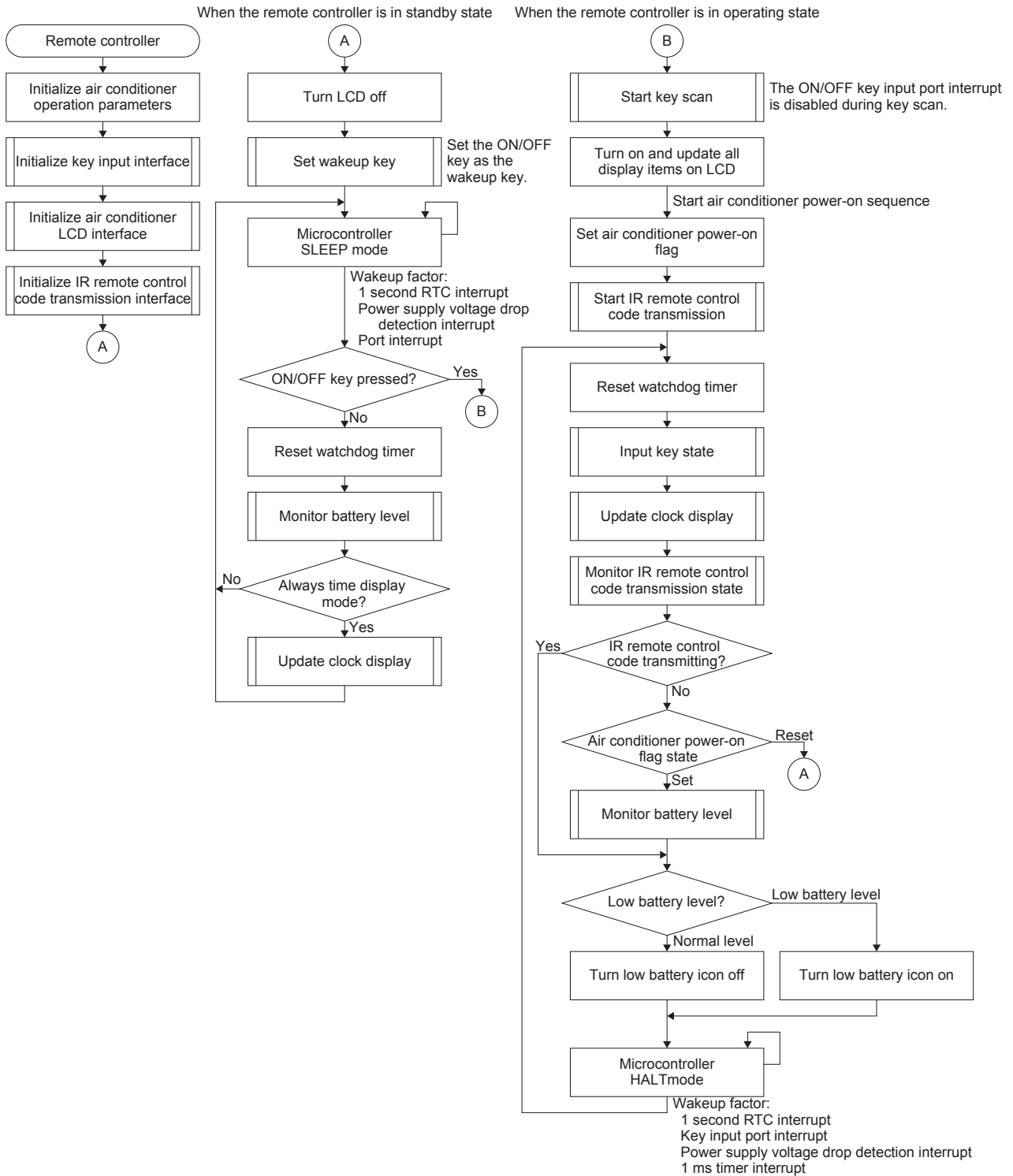

5.3.4.4.1 Key Input Processing

The key code (pressed key) and key event (key input state transition) are acquired as a key input state from the key input interface. The key input processing is performed using it.

- (1) When the ON/OFF key is pressed, air conditioner power-on/off processing is performed.
- (2) When another key is pressed, a key input processing according to the current operation mode (normal operation mode, clock setting mode, or timer setting mode) is performed.

The following shows the flowchart:

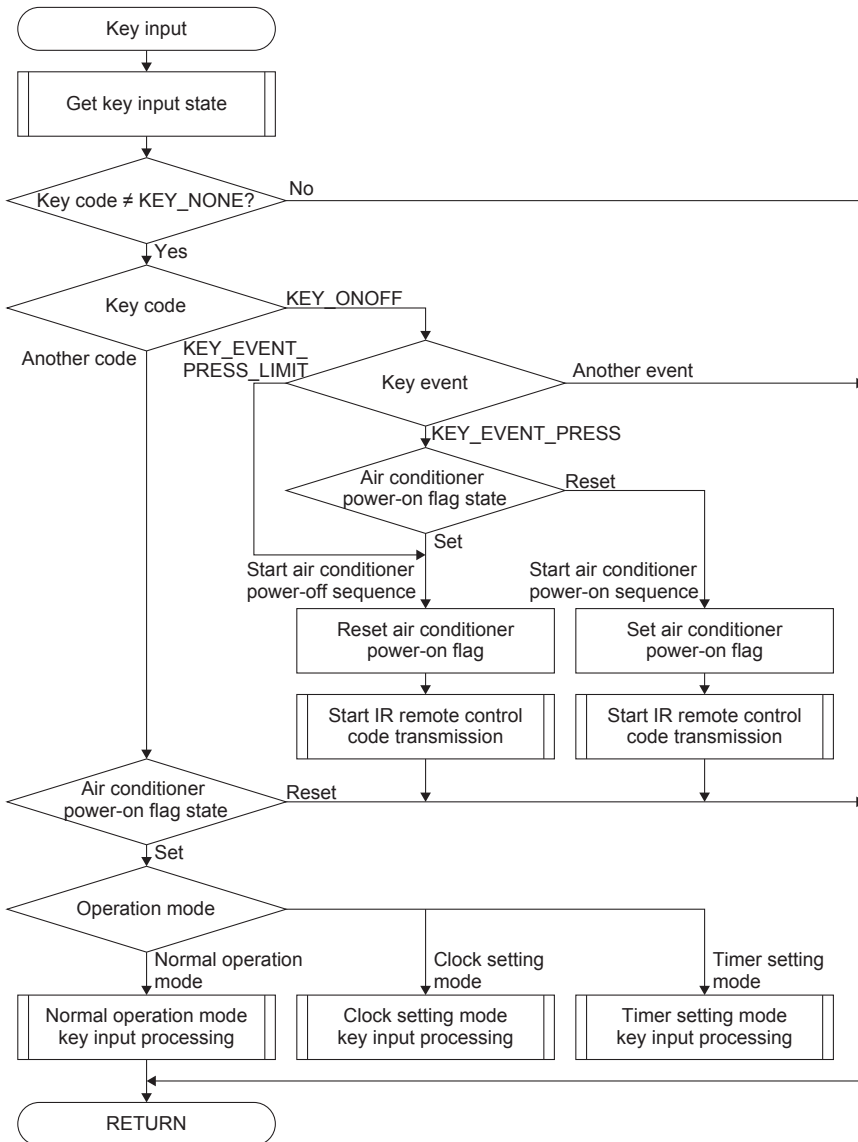

Key Code Table

Key name	Key definition
No pressed key	KEY_NONE
ON/OFF (SW7)	KEY_ONOFF
MODE (SW6)	KEY_MODE
TEMP (SW8)	KEY_TEMP_UP
SETTINGΔ (SW8)	KEY_SETTING_UP
TEMP (SW4)	KEY_TEMP_DN
SETTING∇ (SW4)	KEY_SETTING_DN
WIND ↓ (SW11)	KEY_WIND_VERT
WIND → (SW9)	KEY_WIND_HORI
WIND FAN (SW10)	KEY_WIND_FAN
CLOCK (SW12)	KEY_CLOCK
TIME (SW13)	KEY_TIME
OK (SW15)	KEY_OK
CANCEL (SW14)	KEY_CANCEL

Key Event Table

Event name	Definition
None	KEY_EVENT_NO
Press	KEY_EVENT_PRESS
Release	KEY_EVENT_RELEASE
Long press	KEY_EVENT_LONG_PRESS
Repeat	KEY_EVENT_REPEAT
Press time limit	KEY_EVENT_PRESS_LIMIT

## 5. Software Description

### 5.3.4.4.2 Normal Operation Mode Key Input Processing

In normal operation mode, the air conditioner operation processing is performed according to the key code.

Key name	Key definition
ON/OFF(SW7)	KEY_ONOFF
MODE(SW6)	KEY_MODE
TEMP/SETTING△(SW8)	KEY_TEMP_UP
TEMP/SETTING▽(SW4)	KEY_TEMP_DN
WIND 1(SW11)	KEY_WIND_VERT
WIND ⇄(SW9)	KEY_WIND_HORI
WIND FAN(SW10)	KEY_WIND_FAN
CLOCK(SW12)	KEY_CLOCK
TIME(SW13)	KEY_TIME

The following shows the flowchart:

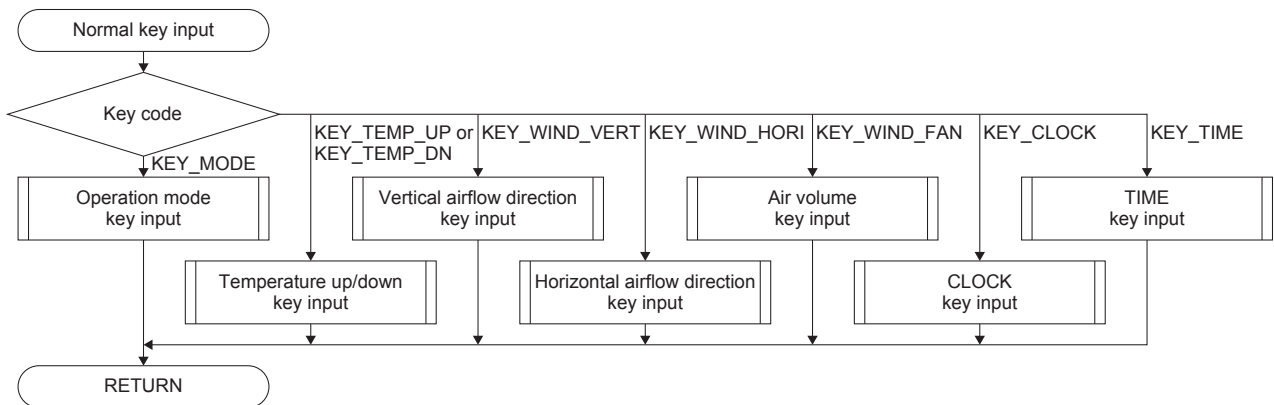

5.3.4.4.3 Operation Mode Key Input Processing

Short pressing of the MODE (SW6) key (key press event) switches operation mode 1 step as the following order:

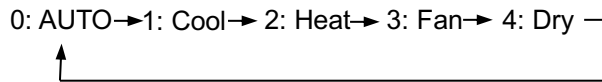

The following shows the flowchart:

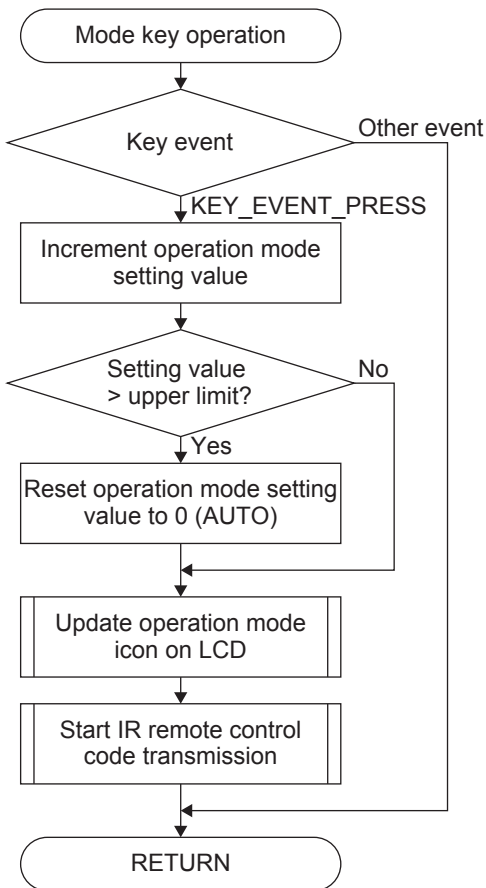

## 5. Software Description

### 5.3.4.4.4 Temperature Up/Down Key Input Processing

Short pressing the TEMP $\Delta$ (SW8) key (key press event) increases the set temperature 1 degree. Long pressing (repeat event) performs fast feed of the setting value.

Short pressing (key press event) the TEMP $\nabla$  (SW4) key lowers the set temperature 1 degree. Long pressing (repeat event) performs fast feed of the setting value.

When the key is long pressed for fast feed setting, the IR remote control code is transmitted after the key has been released.

The following shows the flowchart:

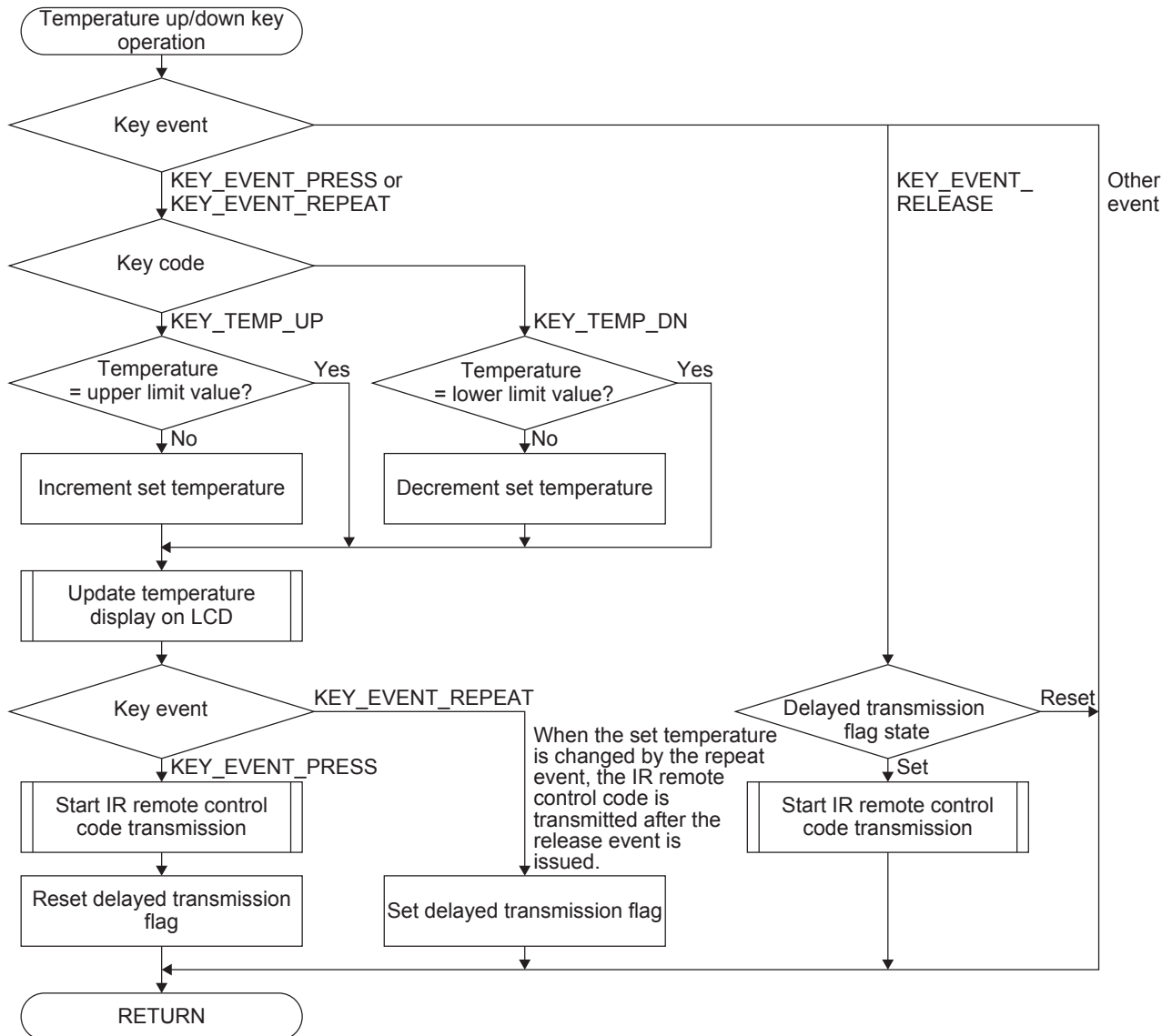

5.3.4.4.5 Vertical Airflow Direction Key Input Processing

Short pressing the WIND↑ (SW11) key (key press event) changes the vertical airflow (flap) direction in the sequence shown below.

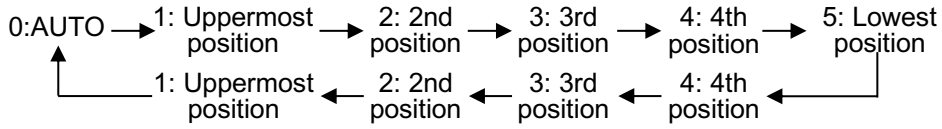

The following shows the flowchart:

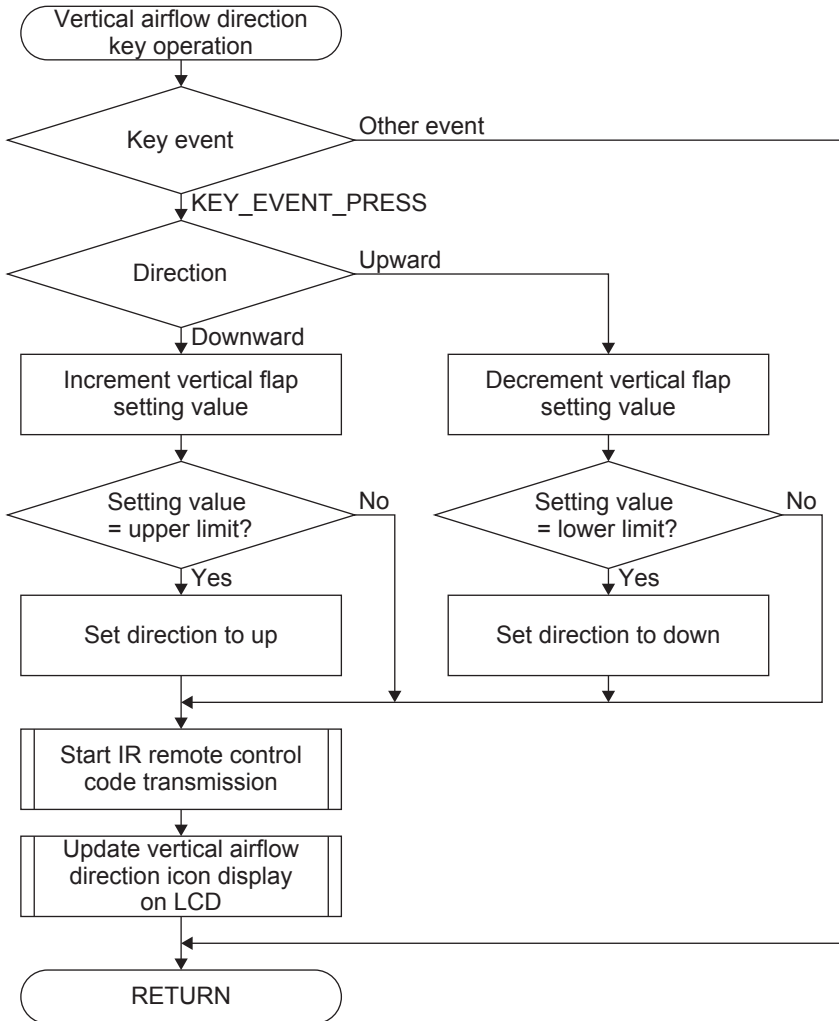

## 5. Software Description

### 5.3.4.4.6 Horizontal Airflow Direction Key Input Processing

In this program, the horizontal airflow direction can be set to AUTO and five fixed directions.

Horizontal airflow direction setting values

Direction	Setting value
AUTO	0
Right 2	1
Right 1	2
Center	3
Left 1	4
Left 2	5

Short pressing the WIND $\leftrightarrow$  (SW9) key (key press event) changes the horizontal airflow (flap) direction in the sequence shown below.

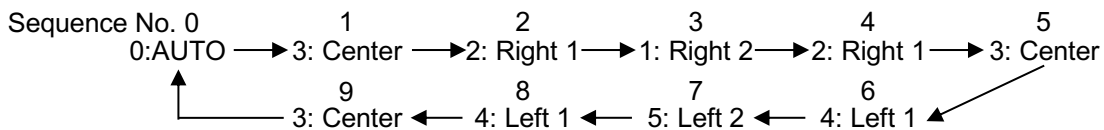

After the direction has changed, the sequence number is converted into the direction setting value using the horizontal airflow direction table.

The following shows the flowchart:

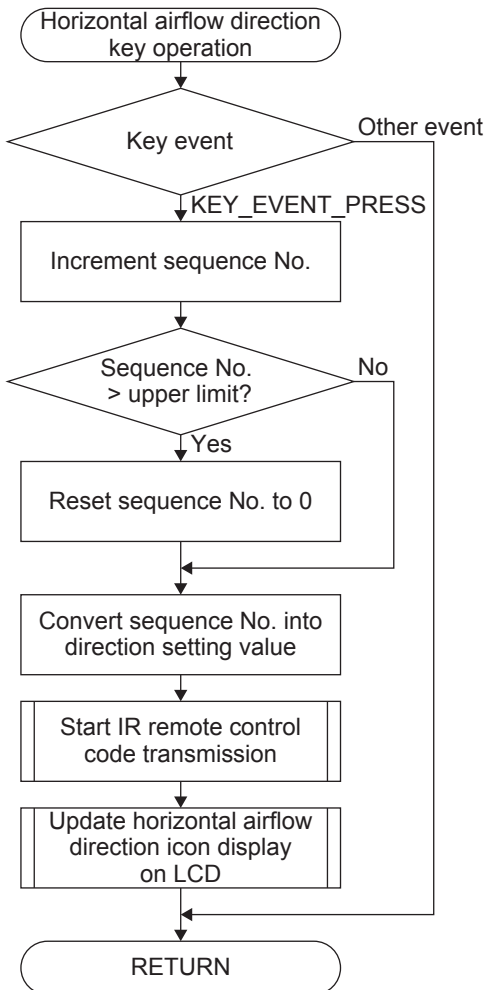

Horizontal Airflow Direction Table

Sequence No.	Direction setting value	Direction
0	0	AUTO
1	3	Center
2	2	Right 1
3	1	Right 2
4	2	Right 1
5	3	Center
6	4	Left 1
7	5	Left 2
8	4	Left 1
9	3	Center

5.3.4.4.7 Air Volume Key Input Processing

Short pressing the WIND FAN (SW10) key (key press event) changes the air volume by 1 step as shown below.

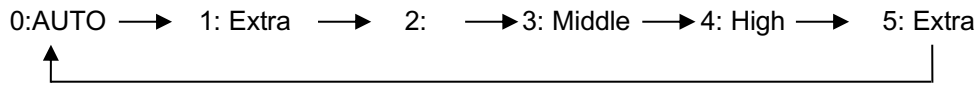

The following shows the flowchart:

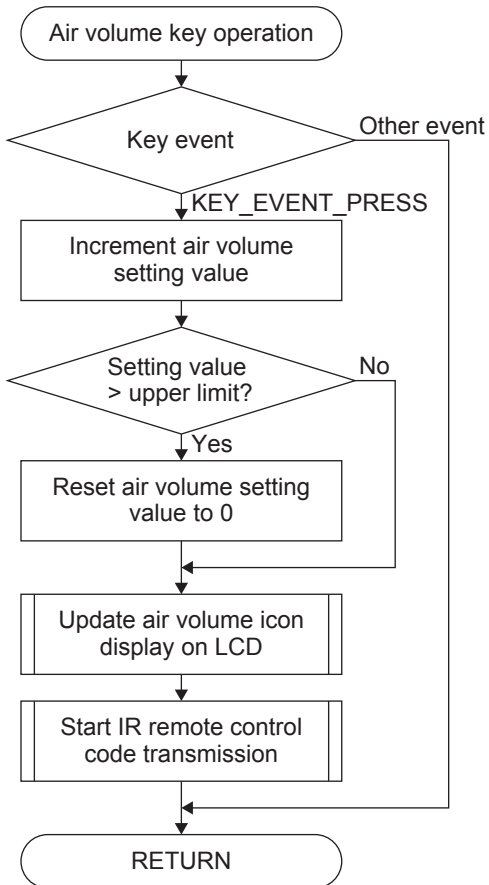

## 5. Software Description

---

### 5.3.4.4.8 CLOCK Key Input Processing

Short pressing the CLOCK (SW12) key (key press event) changes the clock display to date display for 3 seconds. Pressing the key for 2(?) seconds or more (long press event) changes the operation mode to clock setting mode.

The following shows the flowchart:

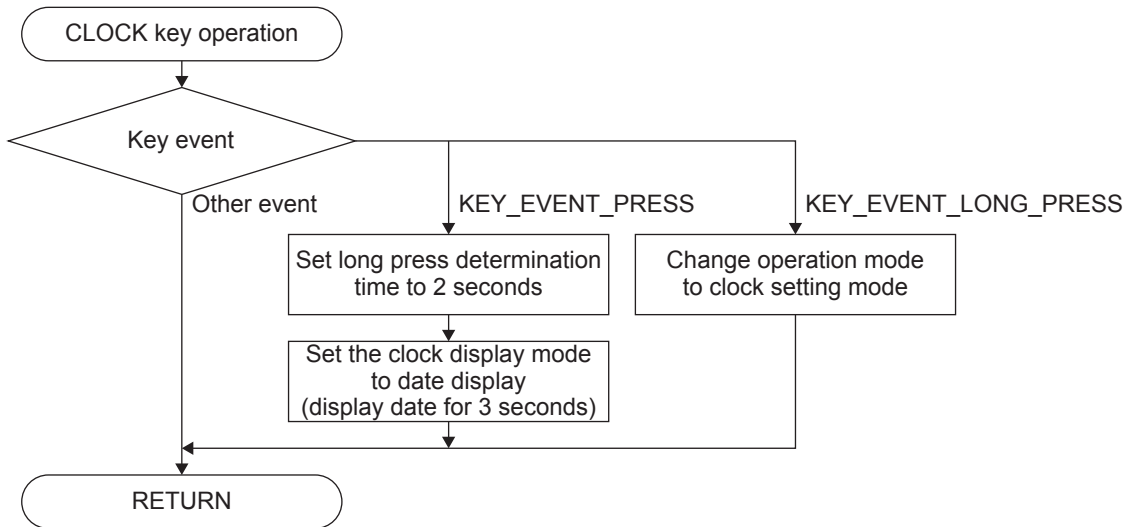

### 5.3.4.4.9 TIME Key Input Processing

Short pressing the TIME (SW13) key (key press event) changes the clock display to timer (reservation time) display for 3 seconds. Pressing the key for 2(?) seconds or more (long press event) changes the operation mode to timer setting mode.

The following shows the flowchart:

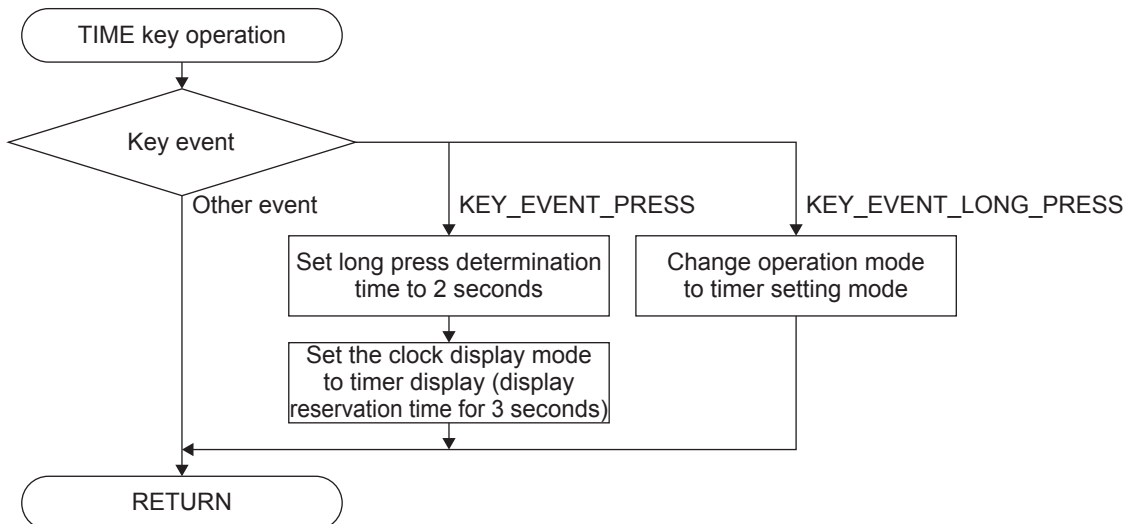

5.3.4.4.10 Clock Setting Key Input Processing

In clock setting mode, year, month, day, 24h/12h mode, hour, and minute can be set in this order. The item blinks when it is able to be changed.

Operation Keys for Setting Clock

Key name	Key definition	Operation
TEMP/SETTING△ (SW8)	KEY_SETTING_UP	Increments the setting value of each item.
TEMP/SETTING▽ (SW4)	KEY_SETTING_DN	Decrements the setting value of each item.
OK (SW15)	KEY_OK	Moves the blink position (setting position) to the next setting item or determines the setting.
CANCEL (SW14)	KEY_CANCEL	Moves the blink position (setting position) to the previous setting item or cancels the setting.



Blinking Position During Clock Setting

The following shows the flowcharts:

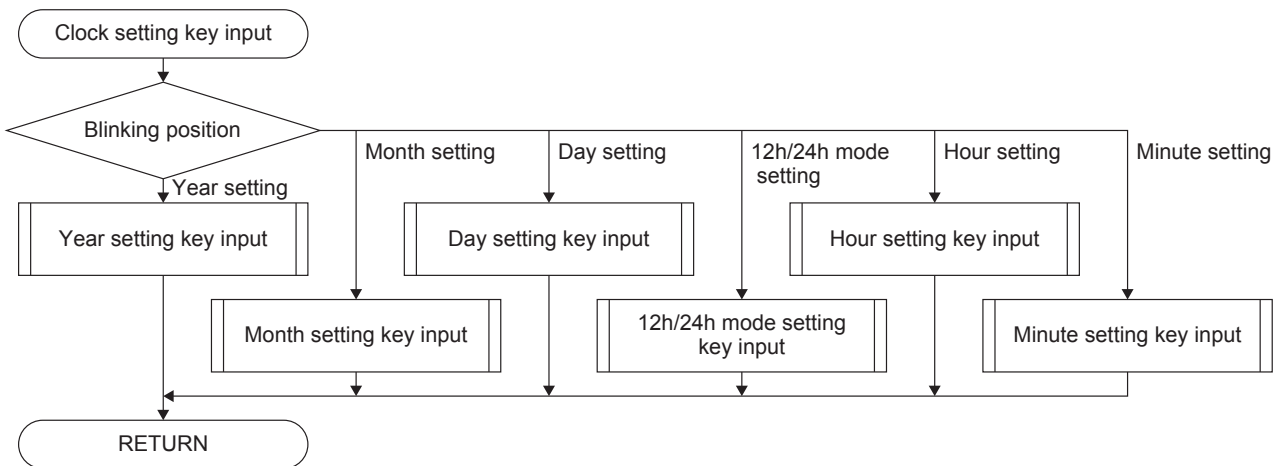

## 5. Software Description

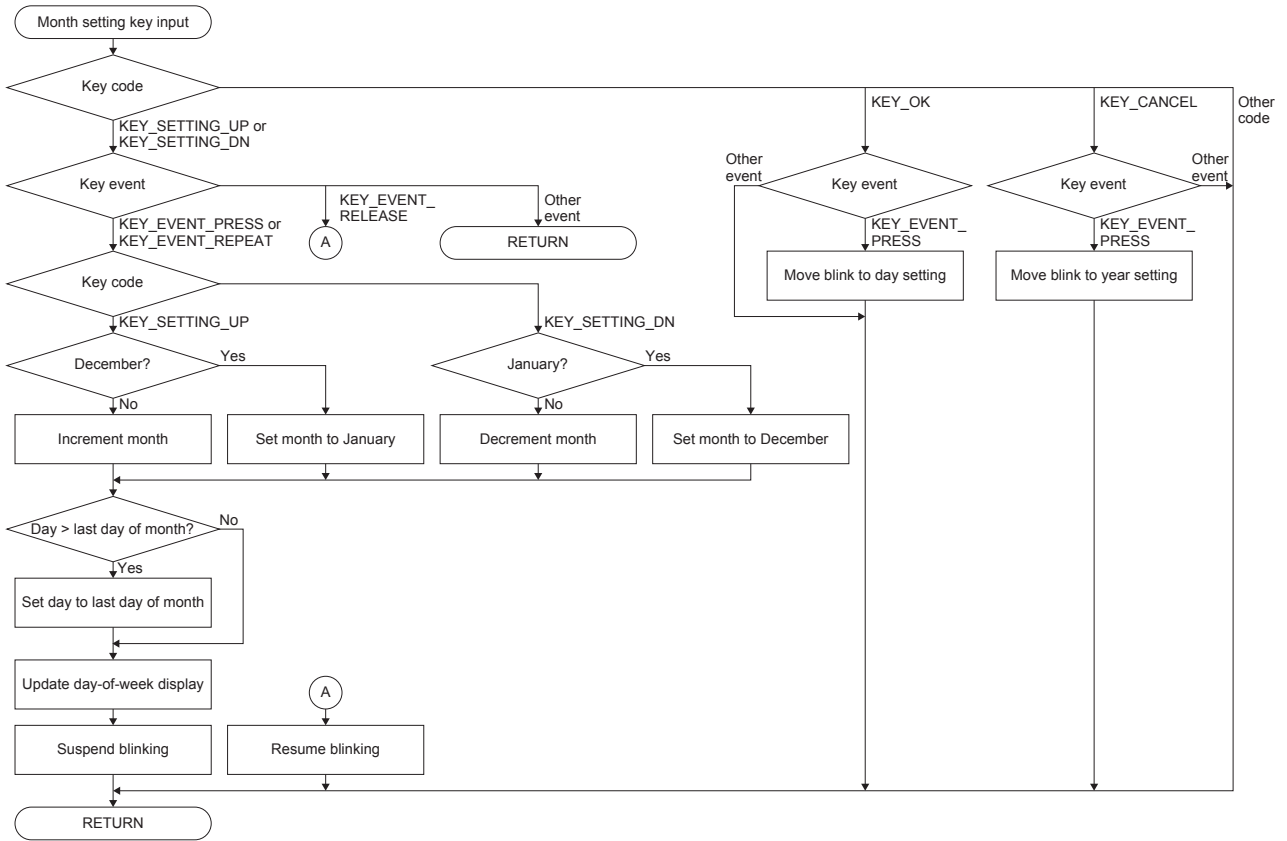
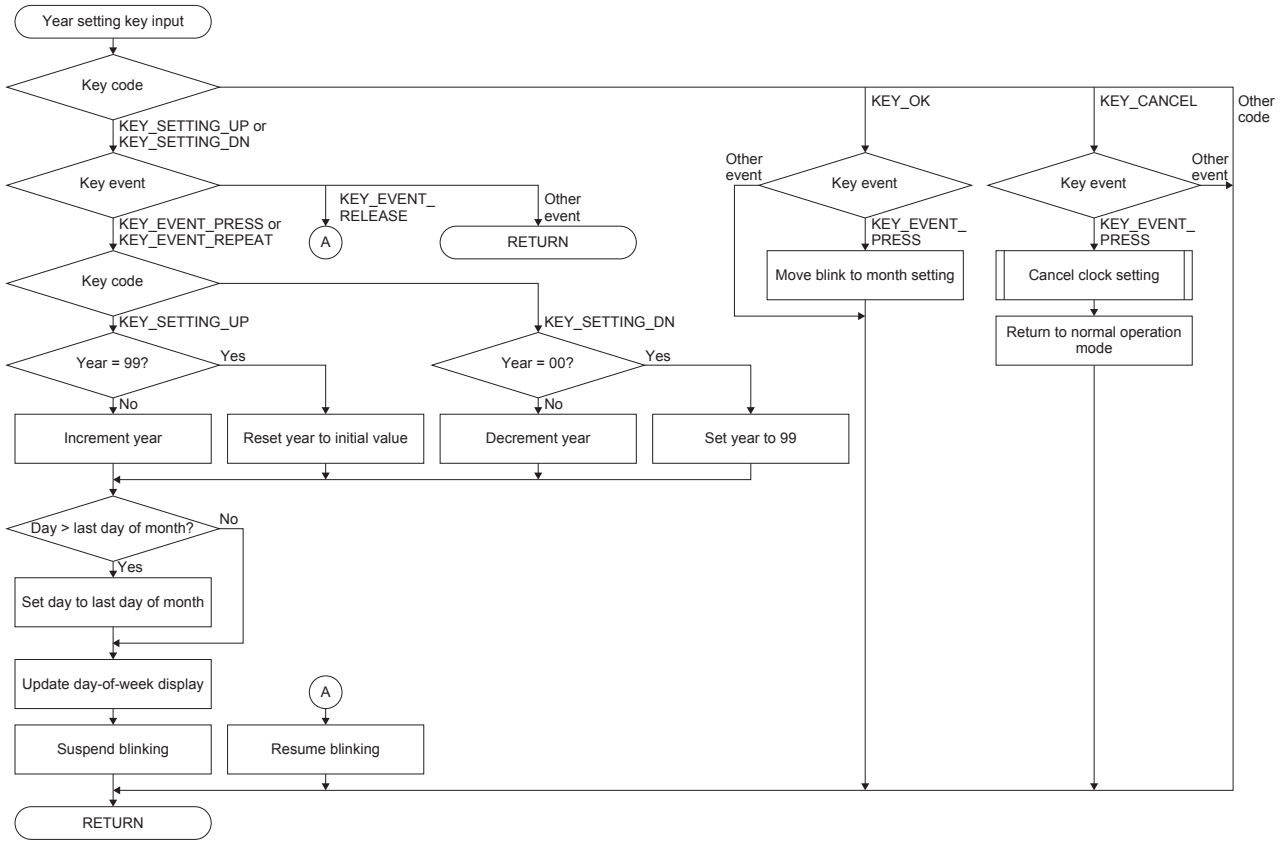

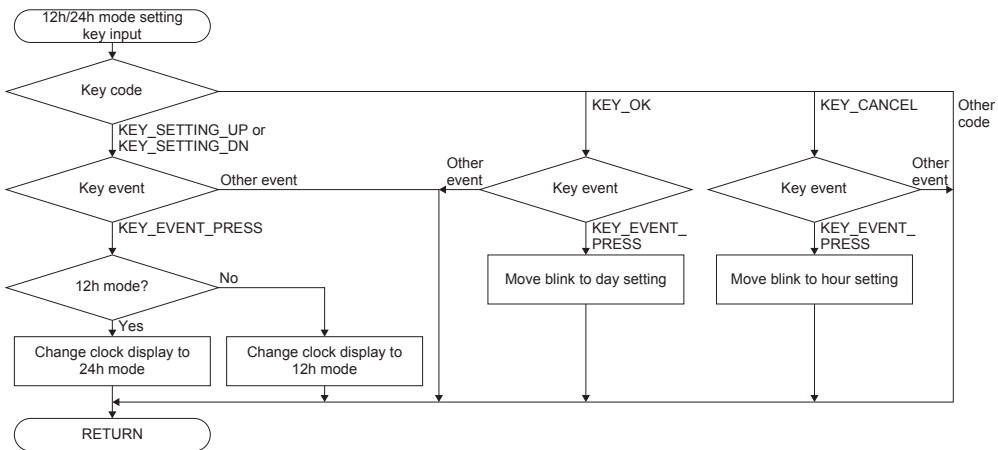
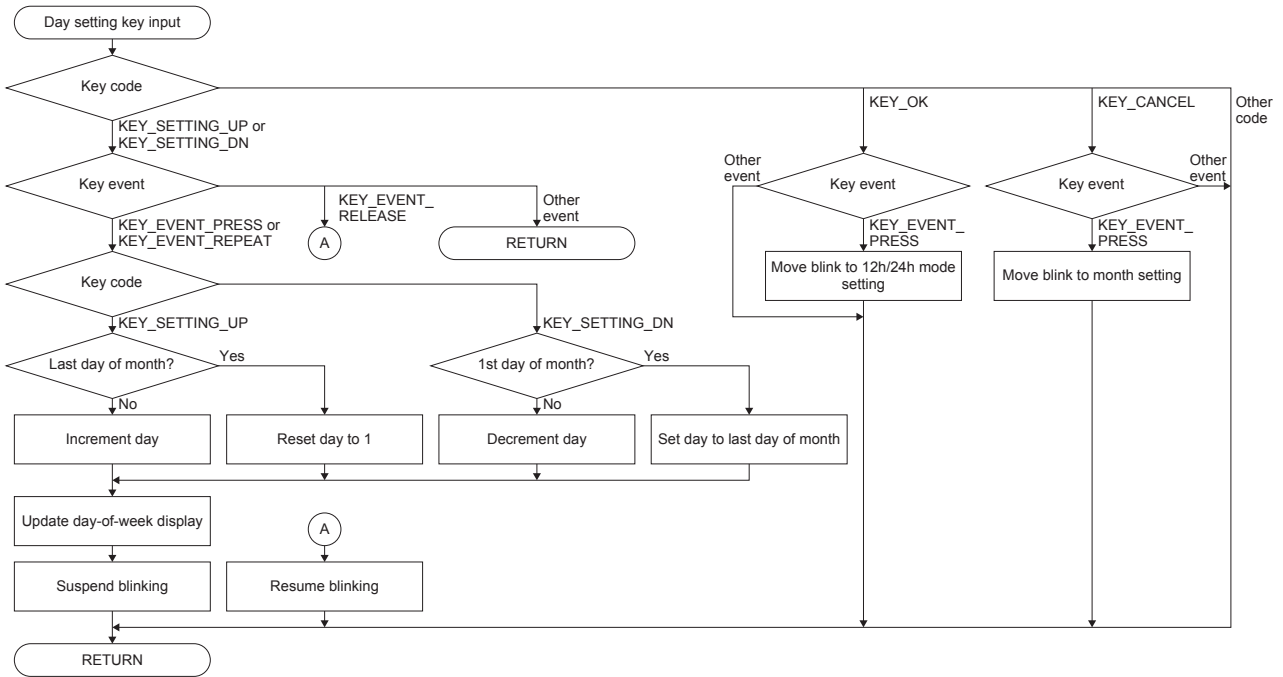

## 5. Software Description

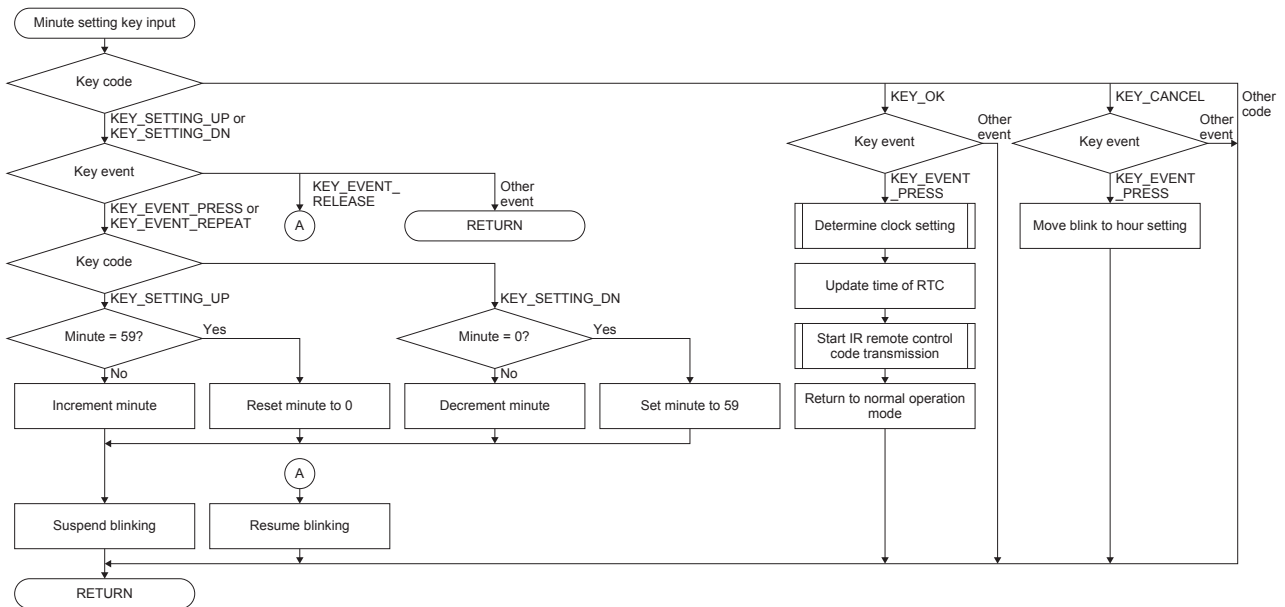
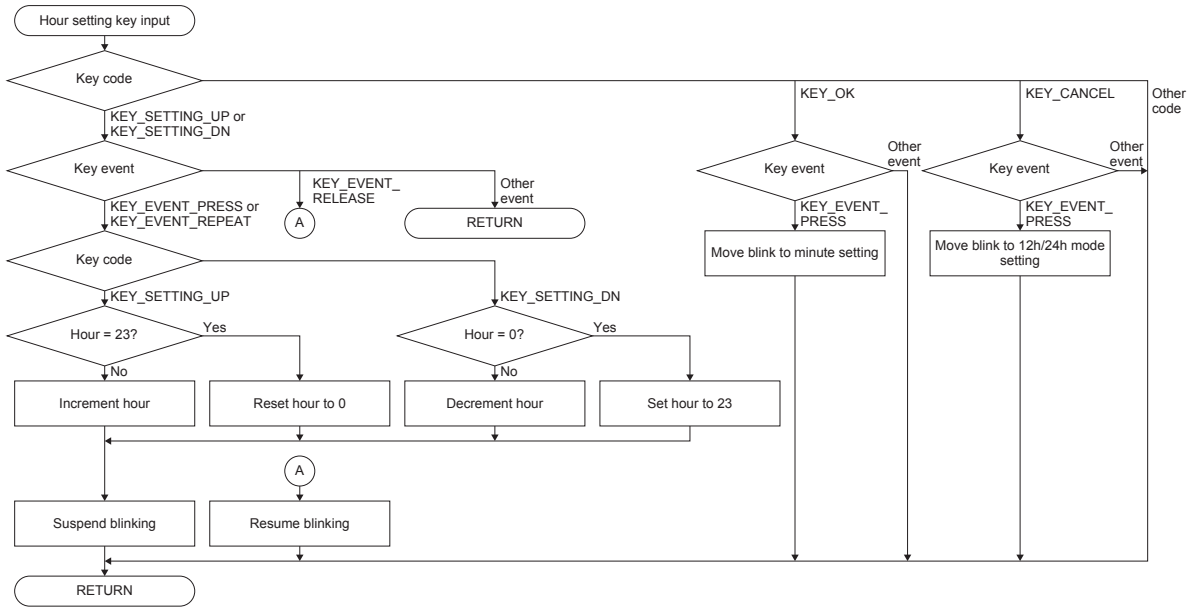

5.3.4.4.11 Timer Setting Key Input Processing

In timer setting mode, first all the setting items blink. Then, ON timer selection, ON timer hour setting, ON timer minute setting, OFF timer selection, OFF timer hour setting, OFF timer minute setting can be done in this order. The item blinks when it is able to be changed.

Operation Keys for Setting Timer

Key name	Key definition	Operation
TEMP/SETTING△ (SW8)	KEY_SETTING_UP	Increases the setting value of each item.
TEMP/SETTING▽ (SW4)	KEY_SETTING_DN	Decrements the setting value of each item.
OK (SW15)	KEY_OK	Moves the blink position (setting position) to the next setting item or determines the setting.
CANCEL (SW14)	KEY_CANCEL	Moves the blink position (setting position) to the previous setting item or cancels the setting.

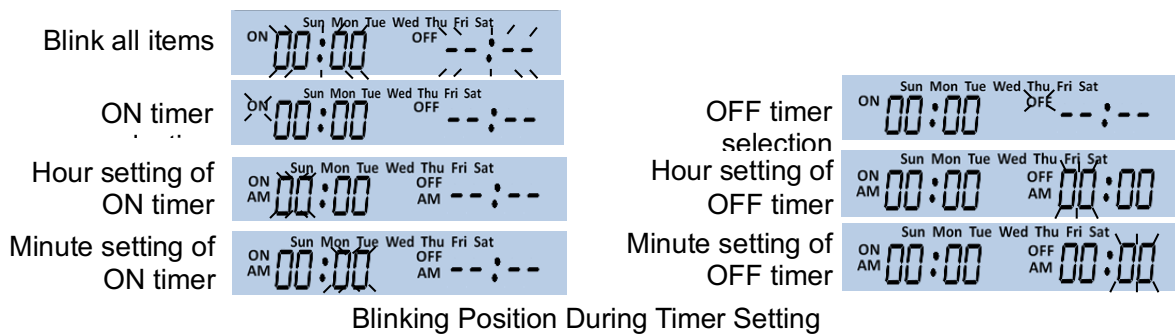

Blinking Position During Timer Setting

The following shows the flowcharts:

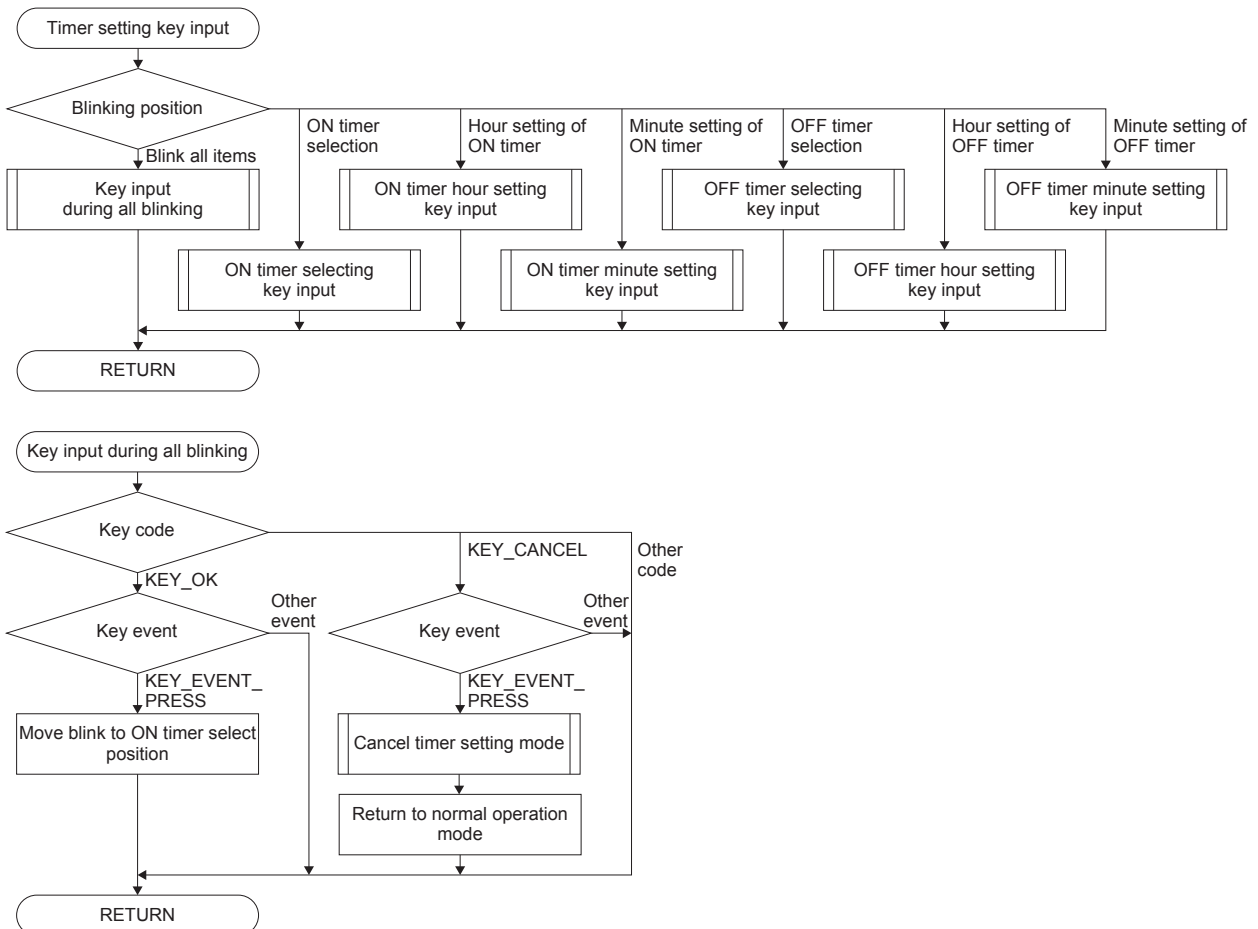

## 5. Software Description

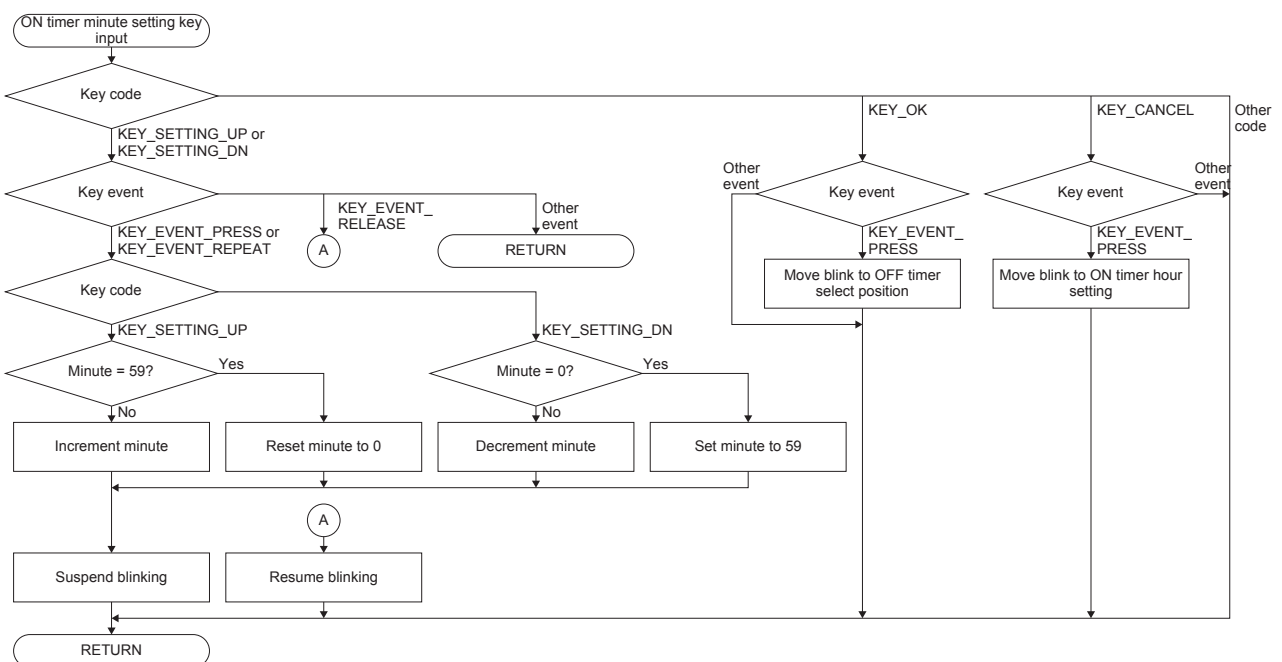
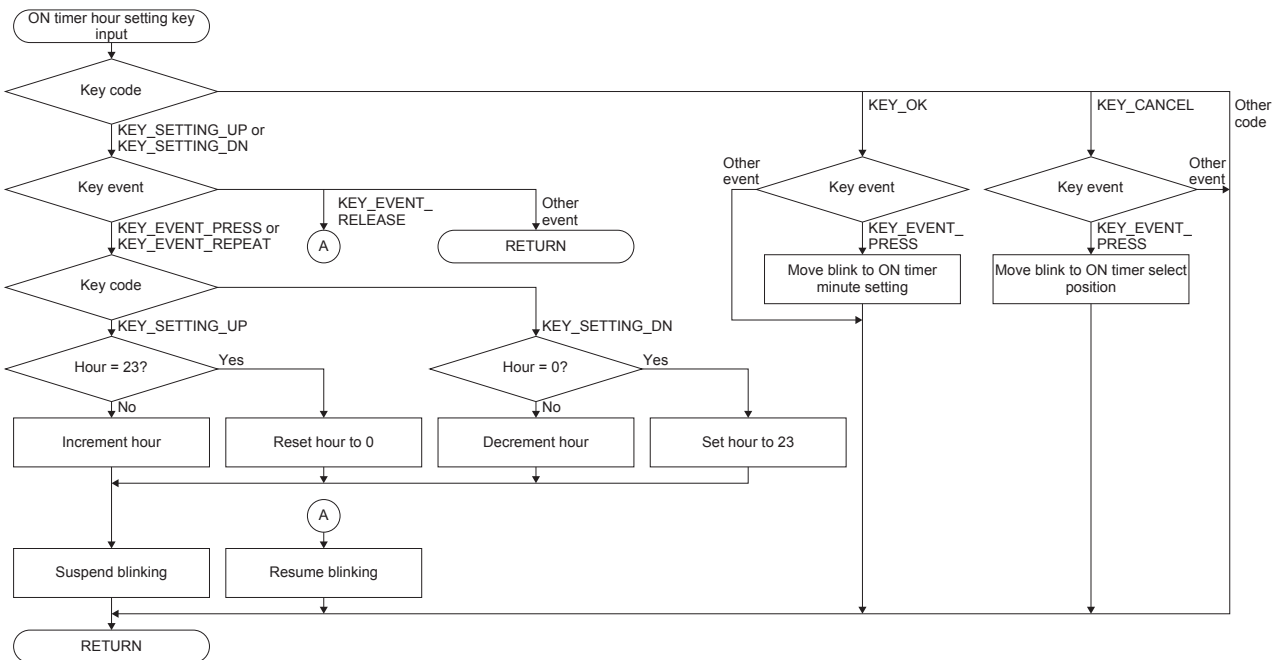
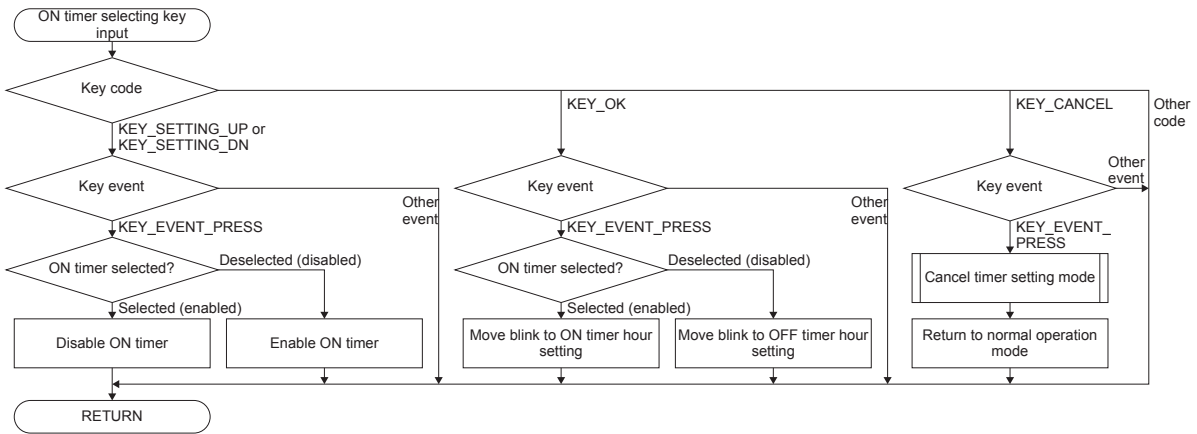

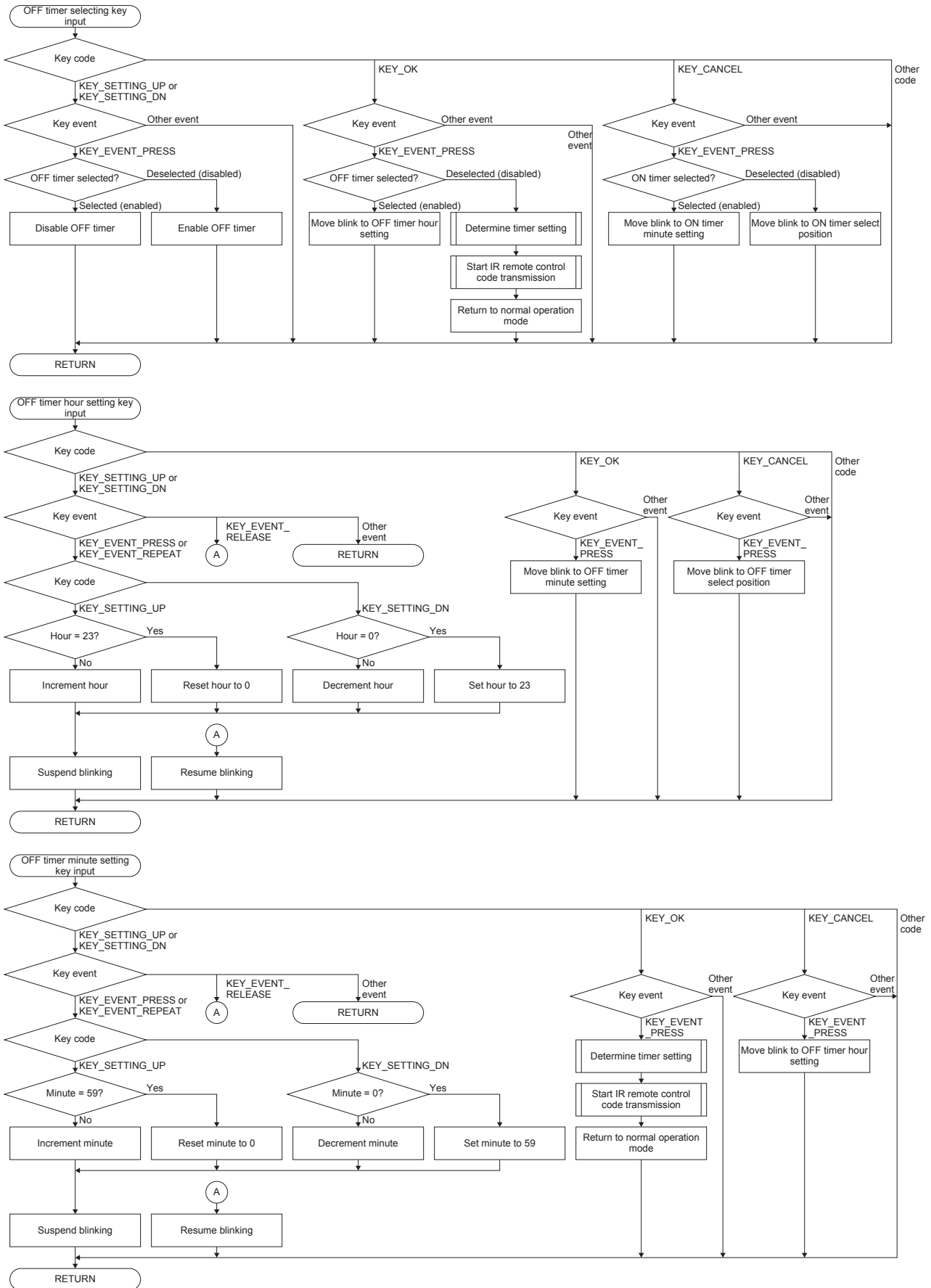

## 5. Software Description

### 5.3.4.4.12 Clock Display Update Processing

This processing updates the clock display at the lower part of the LCD.  
The items listed in the table below are displayed on the clock display portion.

Operation mode	Clock display mode	Displayed contents
Normal operation	Time display	The current time is displayed.
	Date display	The current date is displayed for 3 seconds.
	Timer display	The reservation times are displayed for 3 seconds.
Clock setting	—	The currently selected clock setting item is blinking.
Timer setting	—	The currently selected timer setting item is blinking.

The following shows the flowchart:

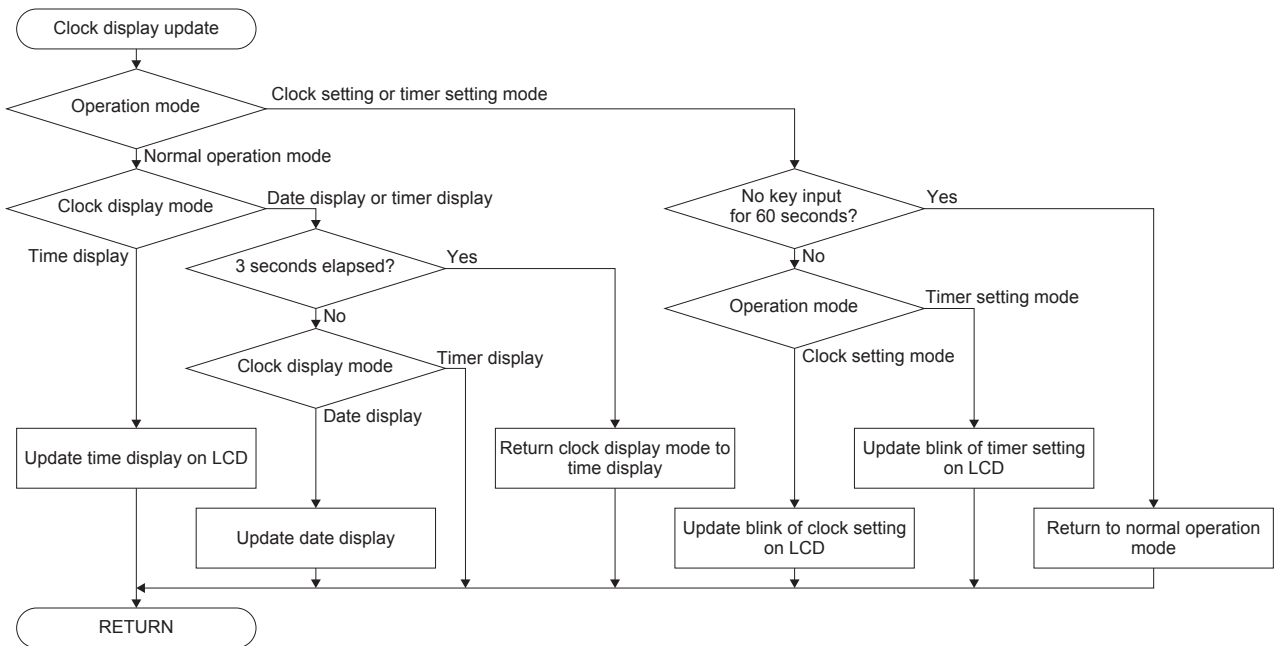

5.3.4.4.13 IR Remote Control Code Transmission Start Processing

This processing transmits the air conditioner operation parameters after converting them into the IR remote control code. The battery level monitor operation is suspended during transmission.

The following shows the flowchart:

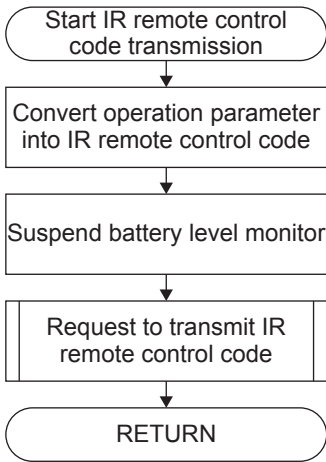

5.3.4.4.14 IR Remote Control Code Transmission Monitor Processing

This processing monitors the IR remote control code transmission state. It displays the transmission icon during transmission. When the transmission has completed, this processing turns the transmission icon off and resumes the battery level monitor operation.

The following shows the flowchart:

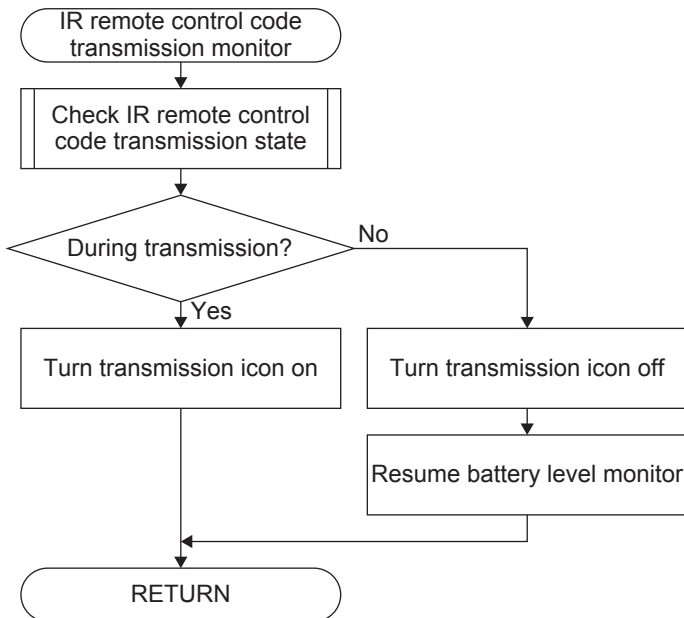



### America

#### Epson America, Inc.

Headquarter:  
3840 Kilroy Airport Way  
Long Beach, California 90806-2452 USA  
Phone: +1-562-290-4677

San Jose Office:  
214 Devcon Drive  
San Jose, CA 95112 USA  
Phone: +1-800-228-3964 or +1-408-922-0200

### Europe

#### Epson Europe Electronics GmbH

Riesstrasse 15, 80992 Munich,  
Germany  
Phone: +49-89-14005-0      FAX: +49-89-14005-110

### Asia

#### Epson (China) Co., Ltd.

4th Floor, Tower 1 of China Central Place, 81 Jianguo Road, Chaoyang  
District, Beijing 100025 China  
Phone: +86-10-8522-1199      FAX: +86-10-8522-1120

#### Shanghai Branch

Room 1701 & 1704, 17 Floor, Greenland Center II,  
562 Dong An Road, Xu Hui District, Shanghai, China  
Phone: +86-21-5330-4888      FAX: +86-21-5423-4677

#### Shenzhen Branch

Room 804-805, 8 Floor, Tower 2, Ali Center, No.3331  
Keyuan South RD (Shenzhen bay), Nanshan District, Shenzhen  
518054, China  
Phone: +86-10-3299-0588      FAX: +86-10-3299-0560

#### Epson Taiwan Technology & Trading Ltd.

15F, No.100, Songren Rd, Sinyi Dist, Taipei City 110. Taiwan  
Phone: +886-2-8786-6688

#### Epson Singapore Pte., Ltd.

1 HarbourFront Place,  
#03-02 HarbourFront Tower One, Singapore 098633  
Phone: +65-6586-5500      FAX: +65-6271-3182

#### Seiko Epson Corp.

##### Korea Office

19F, KLI 63 Bldg, 60 Yoido-dong,  
Youngdeungpo-Ku, Seoul 150-763, Korea  
Phone: +82-2-784-6027      FAX: +82-2-767-3677

---

#### Seiko Epson Corp.

##### Sales & Marketing Division

##### Device Sales & Marketing Department

421-8, Hino, Hino-shi, Tokyo 191-8501, Japan  
Phone: +81-42-587-5816      FAX: +81-42-587-5116