

SOT-89-3L Three Terminal Regulator 三端稳压 IC

■ Features 特点

Pin 脚位: 1.Output 输出 2.Ground 地 3.Input 输入

Output Voltage 输出电压: 15V

Output Current 输出电流: 0.1A

Power dissipation 耗散功率: 0.5W

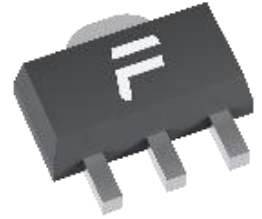
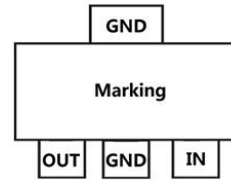

■ Absolute Maximum Ratings 最大额定值

($T_A=25^{\circ}\text{C}$ unless otherwise noted 如无特殊说明, 温度为 25°C)

Characteristic 特性参数	Symbol 符号	Rat 额定值	Unit 单位
Input Voltage 输入电压	V_i	35	V
Operating Current 工作电流	I_o	100	mA
Power dissipation 耗散功率	P_D	600	mW
Thermal Resistance Junction-Ambient 热阻	$R_{\theta JA}$	200	$^{\circ}\text{C}/\text{W}$
Solder Temperature 焊接温度/时间	T_d	260	$^{\circ}\text{C}$
Solder Temperature/Time 焊接时间	T_d	10	S
Operating Ambient Temperature 工作温度	T_A	-20~+120	$^{\circ}\text{C}$
Junction and Storage Temperature 结温和储藏温度	T_J, T_{stg}	125, -55to+150	$^{\circ}\text{C}$

■ Device Marking 产品字标

78L15-2AF=78L15

■ Electrical Characteristics 电特性

($V_i=23V$ $I_o=40mA$ $C_i=0.33\mu F$ $C_o=0.1\mu F$ $T_A=25^\circ C$ unless otherwise noted 如无特殊说明)

Characteristic 特性参数	Symbol 符号	Test Condition 测试条件	Min 最小值	Type 典型值	Max 最大值	Unit 单位
Output Voltage 输出电压	V_o	$V_i=23V$ $I_o=40mA$	14.55	15	15.45	V
Output Voltage 输出电压	V_o	$17.5V \leq V_i \leq 30V$ $1mA \leq I_o \leq 50mA$	14.25		15.75	V
Output Voltage 输出电压	V_o	$17.5V \leq V_i \leq 30V$ $1mA \leq I_o \leq 100mA$	14.25		15.75	V
Output Current 输出电流	I_o	$V_i=23V$		100		mA
Dropout Voltage 落差电压	V_D	$I_o=40mA$		1.7		V
Quiescent Current 静态电流	I_q	$V_i=23V$ $I_o=0$		3	6	mA
Quiescent Current Change 静态电流变化	ΔI_q	$20V \leq V_i \leq 30V$			1.5	mA
Quiescent Current Change 静态电流变化	ΔI_q	$1mA \leq I_o \leq 40mA$			0.1	mA
Line Regulation 线性调整	ΔV_o	$I_o=40mA$ $17.5V \leq V_i \leq 30V$		25	250	mV
Line Regulation 线性调整	ΔV_o	$I_o=40mA$ $25V \leq V_i \leq 30V$		20	250	mV
Load Regulation 负载调整	ΔV_o	$1mA \leq I_o \leq 100mA$ $V_i=23V$		25	150	mV
Temperature Coefficient of V_o 输出电压温度系数	$\Delta V_o/\Delta T$	$I_o=5mA$		1.25		mV/ $^\circ C$
	$\Delta V_o/(V_o \cdot \Delta T)$			84		ppm/ $^\circ C$
Output Noise Voltage 噪声电压	V_N	$10Hz \leq f \leq 100kHz$		90		μV
Ripple Rejection 纹波抑制	RR	$18.5V \leq V_i \leq 28.5V$ $f=120Hz$	34	39		dB

■Equivalent Circuit 等效电路

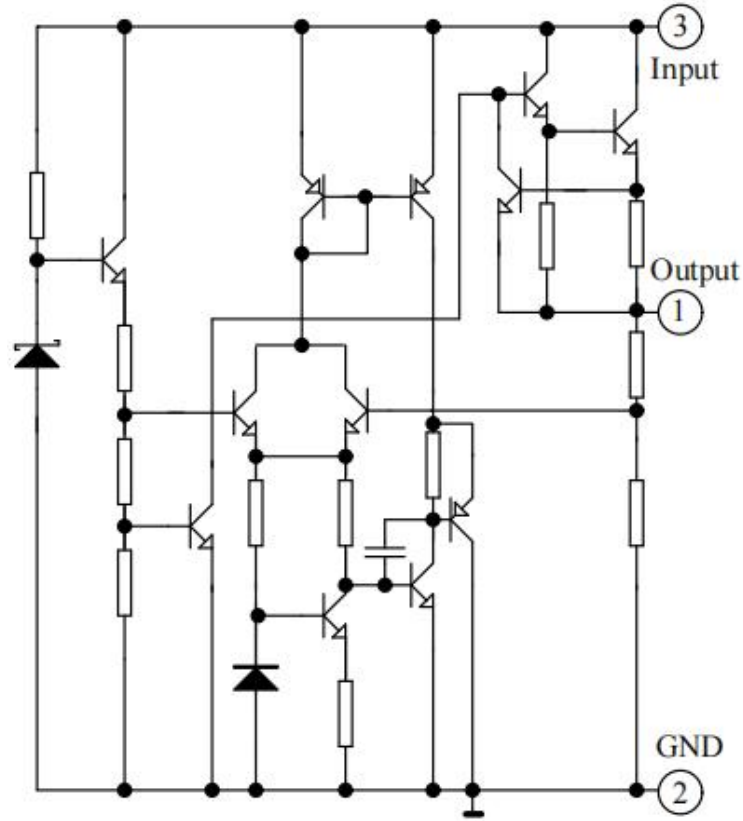

■Application Circuit 应用电路

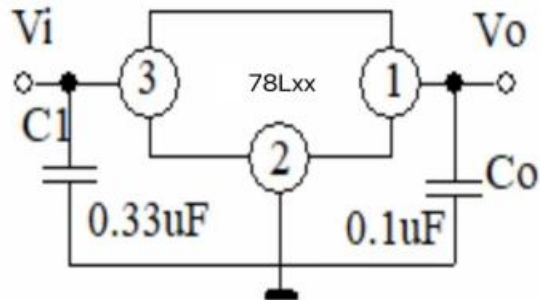

■ SOT-89-3L Dimension 外形封装尺寸

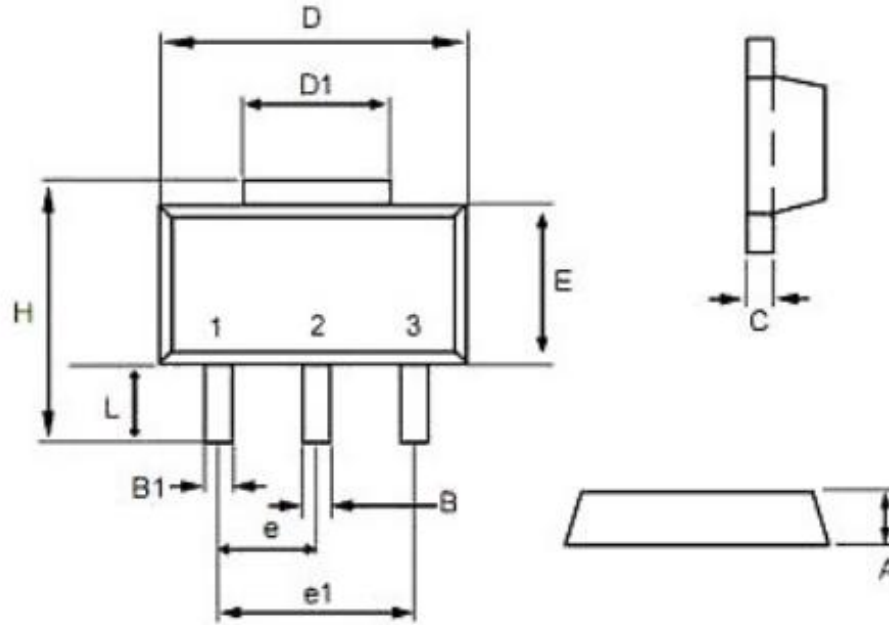

Symbol	Dimensions In Millimeters		Dimensions In Inches	
	Min	Max	Min	Max
A	1.40	1.60	0.055	0.063
B	0.40	0.56	0.016	0.022
B1	0.35	0.48	0.014	0.019
C	0.35	0.44	0.014	0.017
D	4.40	4.60	0.173	0.181
D1	1.35	1.83	0.053	0.072
e	1.45	1.55	0.057	0.061
e1	2.95	3.05	0.116	0.120
E	2.29	2.60	0.090	0.102
H	3.75	4.25	0.148	0.167
L	0.80	1.20	0.031	0.047