

CMOS 4-BIT SINGLE CHIP MICROCOMPUTER
S5U1C63000H6 Manual
(S1C63 Family In-Circuit Emulator)

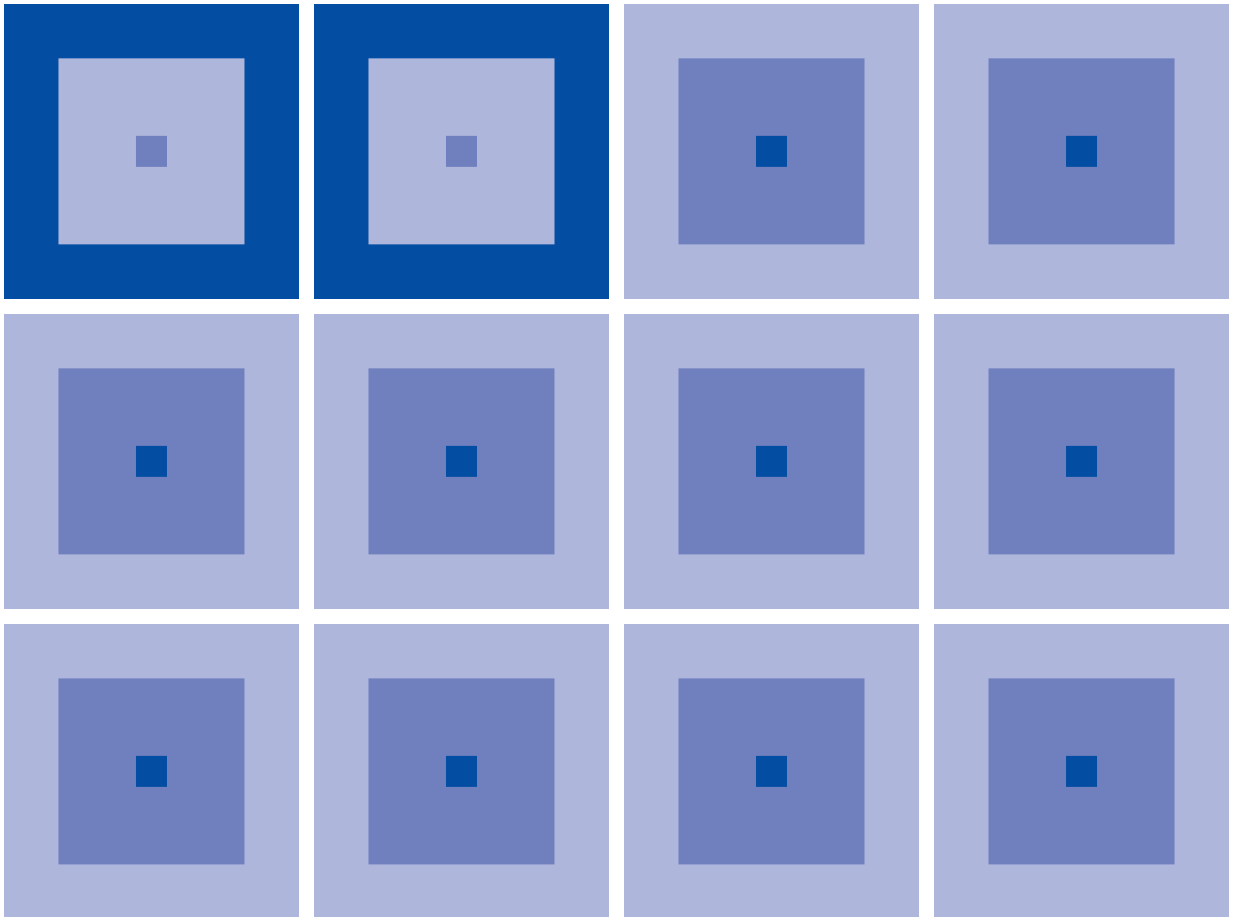

Evaluation board/kit and Development tool important notice

1. This evaluation board/kit or development tool is designed for use for engineering evaluation, demonstration, or development purposes only. Do not use it for other purpose. It is not intended to meet the requirement of design for finished product.
2. This evaluation board/kit or development tool is intended for use by an electronics engineer, and it is not the product for consumer. The user should use this goods properly and safely. Seiko Epson dose not assume any responsibility and liability of any kind of damage and/or fire coursed by usage of it. User should cease to use it when any abnormal issue occurs even during proper and safe use.
3. The part used for this evaluation board/kit or development tool is changed without any notice.

NOTICE

No part of this material may be reproduced or duplicated in any form or by any means without the written permission of Seiko Epson. Seiko Epson reserves the right to make changes to this material without notice. Seiko Epson does not assume any liability of any kind arising out of any inaccuracies contained in this material or due to its application or use in any product or circuit and, further, there is no representation that this material is applicable to products requiring high level reliability, such as, medical products. Moreover, no license to any intellectual property rights is granted by implication or otherwise, and there is no representation or warranty that anything made in accordance with this material will be free from any patent or copyright infringement of a third party. When exporting the products or technology described in this material, you should comply with the applicable export control laws and regulations and follow the procedures required by such laws and regulations. You are requested not to use, to resell, to export and/or to otherwise dispose of the products (and any technical information furnished, if any) for the development and/or manufacture of weapon of mass destruction or for other military purposes.

All brands or product names mentioned herein are trademarks and/or registered trademarks of their respective companies.

Configuration of product number

Devices

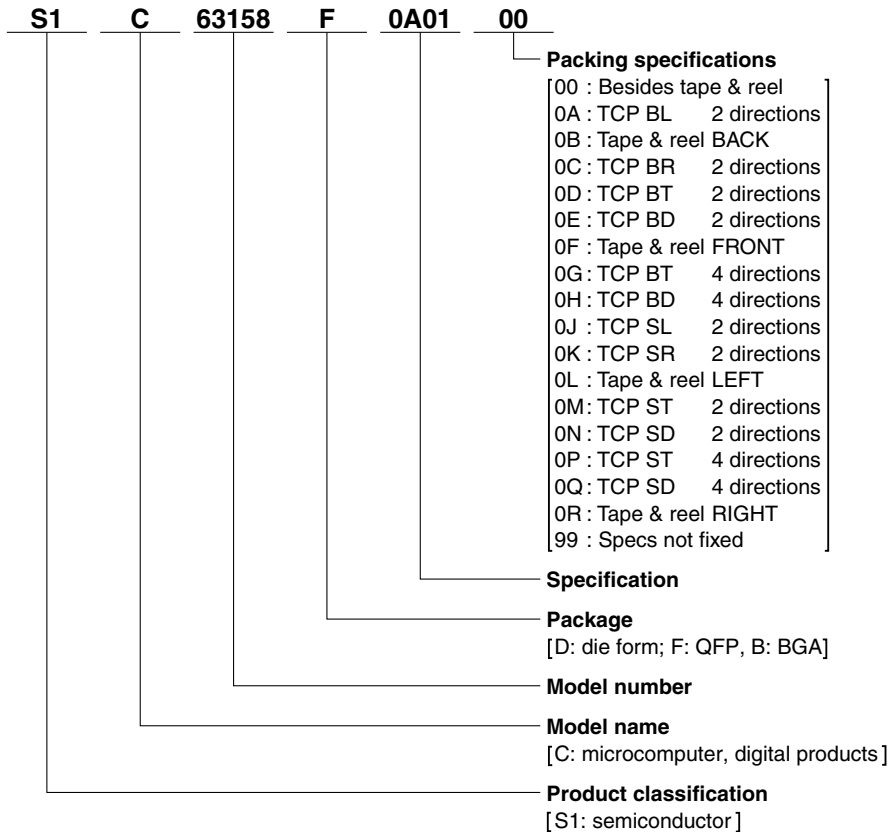

Development tools

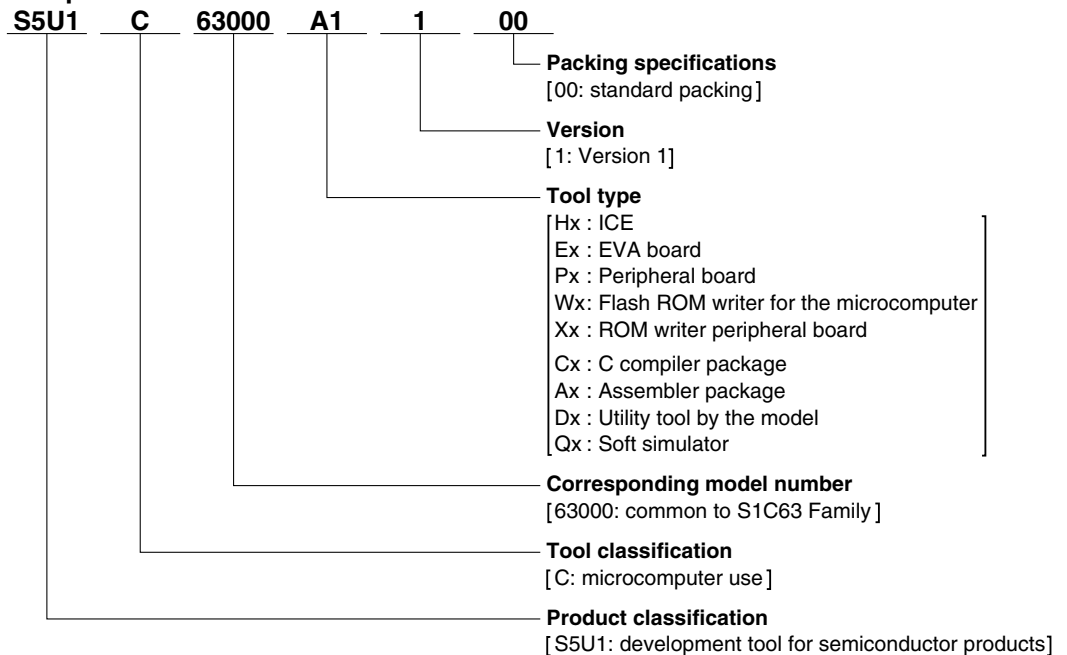

– Contents –

1 Introduction	1
2 S5U1C63000H6 Package	2
2.1 Components.....	2
2.2 Component Specifications	3
2.3 Environmental Condition for Operation	3
2.4 Specifications of the Operation Panels	4
3 Connection	5
3.1 AC Cable.....	5
3.2 DC Cable.....	5
3.3 Connection with Host Computer	5
3.4 Installing Peripheral Circuit Board (S5U1C63xxxP)	6
4 Getting Started	7
5 Operations and Functions of the S5U1C63000H6	8
5.1 Outline of Operation	8
5.2 Break Function	9
5.3 Monitoring Terminals	9
5.4 Display During Execution and During Break	10
5.5 Break Commands	10
5.6 Target Interrupt and Break.....	11
5.7 Trace Function.....	11
5.8 Trace Mode.....	12
5.9 Trace Trigger Point.....	12
5.10 Coverage Function	12
5.11 Measurement of Execution Time.....	12
5.12 Self-Diagnostic Function	13
5.13 Restrictions on Emulation	13
6 LCD Driver	16
6.1 Differences from Actual IC	16
6.2 Connection with the Target System.....	16
7 Notes on Use	18
7.1 Notes on Operations	18
7.2 Differences from Actual IC	18
8 Maintenance and Warranty	19
8.1 Self-Diagnostic Test.....	19
8.2 Warranty	19
9 Troubleshooting	20

1 Introduction

S5U1C63000H6 (S1C63 Family In-Circuit Emulator) is a hardware tool to effectively develop software for the S1C63 Family, 4-bit single chip microcomputers. In combination with a peripheral circuit board (S5U1C63xxxP), it provides the development environment of the software using a personal computer as a host computer, which requires Windows 2000/XP.

This manual describes the operation of the S5U1C63000H6 hardware and connections of the S5U1C63000H6 system. Refer to the “S5U1C63000A Manual” for how to use the control software on the PC (debugger).

Figure 1.1 shows the external view of the S5U1C63000H6.



Figure 1.1 External View of S5U1C63000H6

2 S5U1C63000H6 Package

2.1 Components

This package is in common with all models of the S1C63 Family. After unpacking the S5U1C63000H6 package, check to see that all of the following components are included. Figure 2.1.1 shows the package structure.

- (1) S5U1C63000H6 (main unit) 1 unit
- (2) USB cable..... 1 cable
- (3) AC adapter..... 1 pcs.
- (4) AC cable..... 1 cable
- (5) Jig for installing / dismantling board 2 pcs.
- (6) S5U1C63000H6 Manual (S1C63 Family In-Circuit Emulator) 1 copy (this manual)
- (7) Flat cable with 50-pin × 2 connectors 1 pair
- (8) Flat cable with 34-pin × 1 connector..... 1 pcs.
- (9) 50-pin connector for target system..... 2 pcs.
- (10) 34-pin connector for target system..... 1 pcs.
- (11) User registration card 1 pcs.
- (12) Warranty card 1 pcs.
- (13) Precautions on using the S5U1C63000H6..... 1 pcs.

Note that the items listed below are not included in this package. These items need to be provided separately.

- (14) S5U1C63xxxP Board (included in the S5U1C63xxxP package)
- (15) S5U1C63xxxP Manual (included in the technical manual for each models)
- (16) S1C63 Family Debugger (included in the S1C63 Family Assembler package)
- (17) S5U1C63000A Manual (included in the S1C63 Family Assembler package)

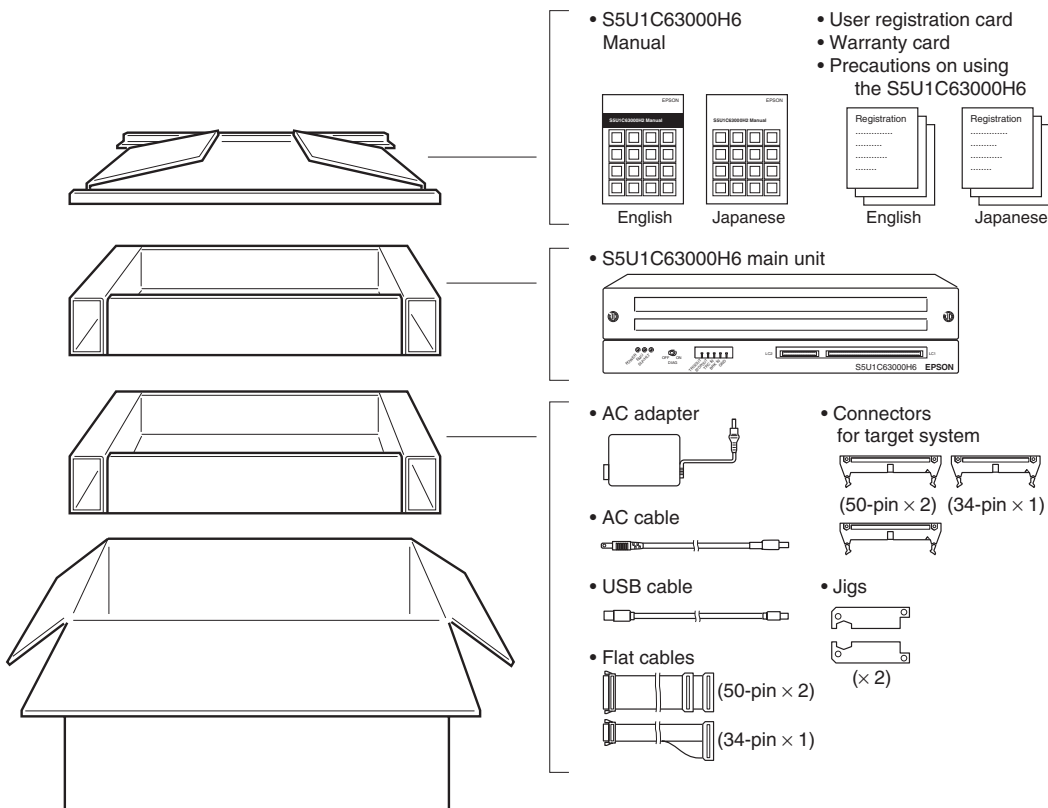

Figure 2.1.1 S5U1C63000H6 Package Structure

2.2 Component Specifications

Table 2.2.1 shows the specifications of the component in the S5U1C63000H6 package.

Table 2.2.1 Specifications of S5U1C63000H6 Components

No.	Components	Items	Specifications	Remarks
1	S5U1C63000H6 (main unit)	Dimensions	282 mm (W) × 177 mm (D) × 70 mm (H)	Rubber feet included
		Weight	Approx. 1.8 kg (main body) Approx. 3.5 kg (total weight of package)	
		External color	Cygnus white	
		Input voltage	DC 12 V	
		Power consumption	3 A, max.	
		Board mounted	Main board (included LCD driver) 1 board	Peripheral circuit board is sold separately.
2	Interface cable	Length	USB cable: 1.5 m	
			LCD cable: 0.4 m	
3	AC adapter	Dimensions	100 mm (W) × 60 mm (D) × 30 mm (H)	
		Input voltage	AC 90 V to 264 V	
		Input frequency	50 Hz to 60 Hz ±3 Hz	
		Power consumption	36 W, max. (in main system load)	
		Output voltage, Current	DC 12 V, 3 A, with over current protection	Outside: 0 V Inside: 12 V
4	AC cable	Length	1.8 m	
		Plug type	2-pin	
5	Accessories	Jig	For installing/dismounting option boards 2 pcs.	
		User connector	3431-6002-LCPL (3M): 1 pcs. 3433-6002-LCPL (3M): 2 pcs.	
		Hardware manual		
		Warranty card, User registration card		
6	Package	Dimension	380 mm (W) × 260 mm (D) × 225 mm (H)	
		Materials	W carton, cardboard	

2.3 Environmental Condition for Operation

Table 2.3.1 shows the environmental conditions to operate S5U1C63000H6 that has to be used.

Table 2.3.1 Environmental Conditions

No.	Items	Specifications	Remarks
1	Operating temperature	5 to 40°C	
2	Storage temperature	-10 to 60°C	
3	Operation humidity	35 to 80%	
4	Storage humidity	20 to 90%	
5	Resistance to vibration	Operating: 0.25 m/s ² Transportation: 1 m/s ²	No condensation

2.4 Specifications of the Operation Panels

Figure 2.4.1 shows the external view of the panels.

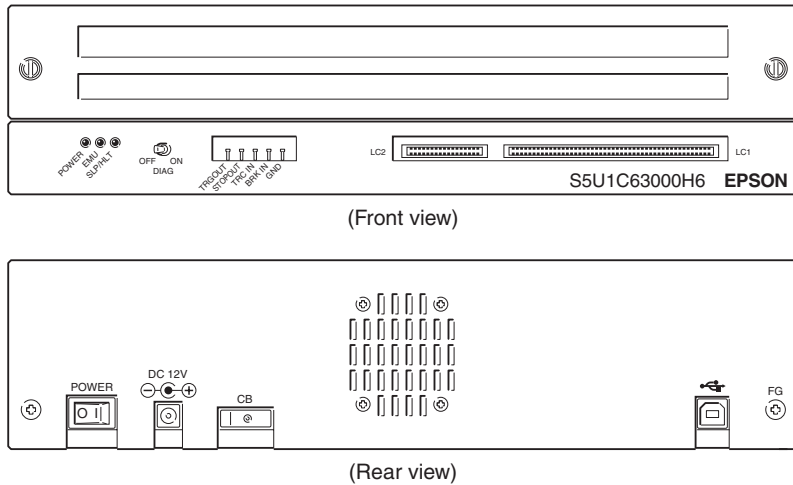



Figure 2.4.1 External View of S5U1C63000H6 Panels

Table 2.4.1 shows the function of each component on the panels.

Table 2.4.1 Function List of Components

No.	Position	Symbol	Name	Function
1	Front panel	POWER	Power on LED	This green LED lights upon power-on of the S5U1C63000H6.
2	Front panel	EMU	Emulation LED	This red LED lights when the target program is in running status.
3	Front panel	SLP/HLT	SLEEP/HALT LED	This yellow LED lights when the S1C63000 CPU executes the HALT or SLP instruction. This LED also lights when the peripheral circuit board has not been installed.
4	Front panel	DIAG	Self-diagnostic select switch	This switch is used to select whether the S5U1C63000H6 self-diagnosis at startup of the debugger will be executed or not.
5	Front panel	TRGOOUT	Trace-trigger output terminal	Upon coincidence of trigger conditions with a tracing trigger point, a pulse is output from this terminal.
6	Front panel	STOPOUT	SLEEP/HALT status output terminal	When the S1C63000 CPU is in HALT or SLEEP status, a low level signal is output from this terminal. This is used to measure execution rate of the CPU. Also this terminal goes low in break status.
7	Front panel	TRCIN	Trace input terminal	Trace information will be stored in the trace memory by connecting a signal of the target system to this terminal.
8	Front panel	BRKIN	Break input terminal	A running program enters break status by input a low level signal to this terminal from the target system.
9	Front panel	GND	Ground terminal	When monitoring the above terminals with an oscilloscope, connect the GND line of the oscilloscope to this terminal. This is also used as a GND when inputting signals to the above terminals.
10	Front panel	LC1, LC2	LCD connectors	These connectors are used to connect an LCD panel.
11	Rear panel	POWER	Power switch	Turns the S5U1C63000H6 power on and off.
12	Rear panel	DC12V	DC input connector	This connector is used to connect the DC cable of the AC adapter for S5U1C63000H6. <u>Be sure to use the AC adapter included in this package.</u>
13	Rear panel	CB	Circuit breaker	The breaker cuts off the power of this system (peripheral board, add-on board and target board) at consumption current of 3 A or more. A small staff of breaker comes up at the shut-off. The staff should be at the recessed position for normal operating status.
14	Rear panel		USB connector	This USB cable connector is used to interface with the host computer.
15	Rear panel	FG	Frame ground	This is the frame ground terminal. We recommend to connect this terminal to the ground line.

3 Connection

This chapter describes the connection between S5U1C63000H6 and a host computer and a Peripheral Circuit Board (S5U1C63xxxP).

3.1 AC Cable

The S5U1C63000H6 package includes a dedicated AC cable (with 2-pin plug) and AC adapter. The AC cable is connected into the AC inlet on the AC adapter.

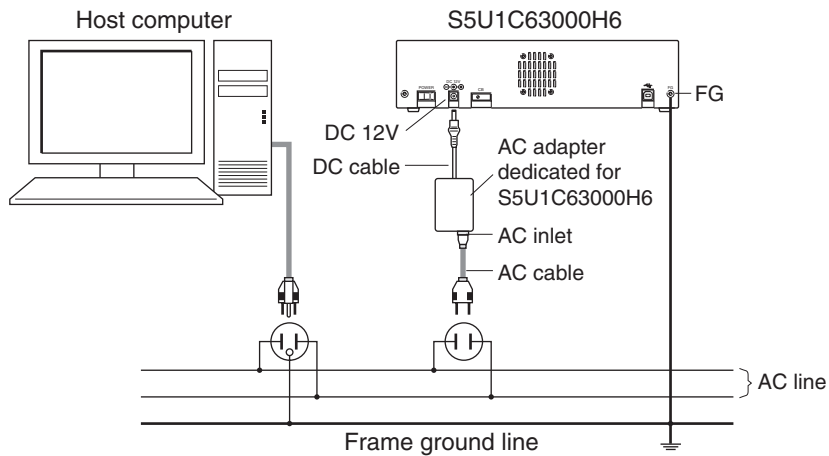

* We recommend to connect between the FG terminal of the S5U1C63000H6 and a frame ground.

Figure 3.1.1 Connection of AC Line

3.2 DC Cable

Connect the DC output cable of the AC adapter to the DC12V connector located at the S5U1C63000H6 rear panel.

3.3 Connecting with Host Computer

Connect between the host computer and the S5U1C63000H6 using the USB cable included in this package.

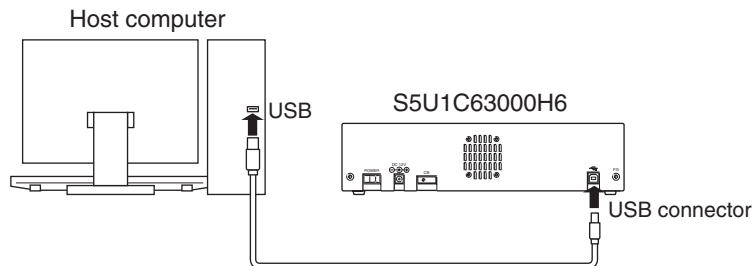

Figure 3.3.1 Connecting with Host Computer

3.4 Installing Peripheral Circuit Board (S5U1C63xxxP)

By installing the S5U1C63xxxP peripheral circuit board (to be separately sold) into a slot of the S5U1C63000H6, a debug system can be made corresponding to each device of the S1C63 Family. Figure 3.4.1 shows installing method of the peripheral circuit board. The S5U1C63000H6 is equipped with an LCD driver function, so an LCD board is not required.

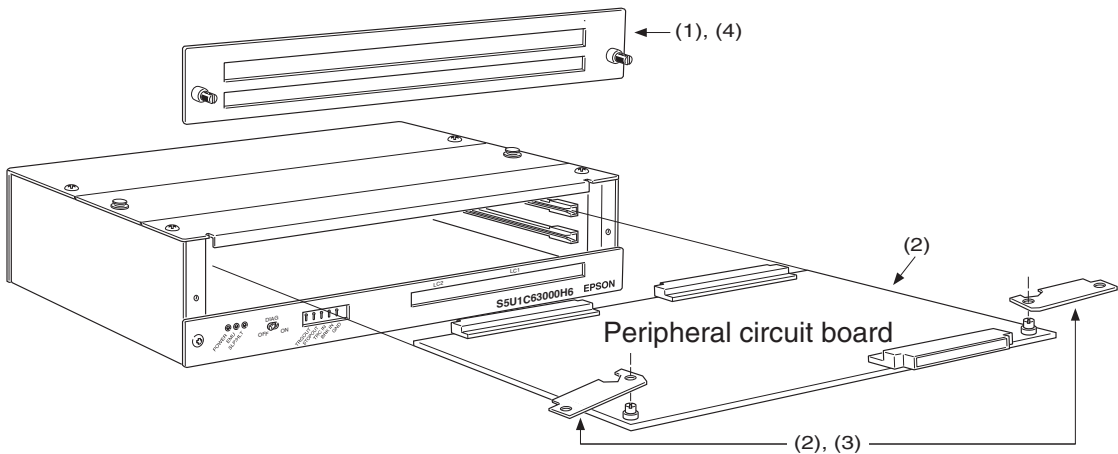

Figure 3.4.1 Installing Peripheral Circuit Board

(1) Unfasten the screws located on the left and right sides of the front panel of the S5U1C63000H6 by turning them counterclockwise then remove the front panel.

(2) Insert the peripheral circuit board into the slot and push it using the jig attached with the S5U1C63000H6 as shown in Figure 3.4.2.

Using this jig as a lever, push it toward the inside of the board evenly on the left and right sides. After confirming that the peripheral circuit board has been firmly fitted into the internal slot of the S5U1C63000H6, remove the jig.

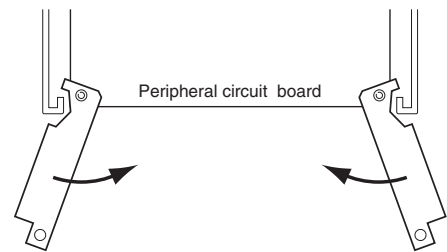

Figure 3.4.2 Installing Peripheral Circuit Board

(3) When dismantling the peripheral circuit board, set the jig into position as shown in Figure 3.4.3. Using this jig as a lever, push it toward the outside of the board evenly on the left and right sides and pull the peripheral circuit board out of the S5U1C63000H6.

(4) Mounting the front panel removed at the step (1) on the main case by pushing and turning two screws located at both side.

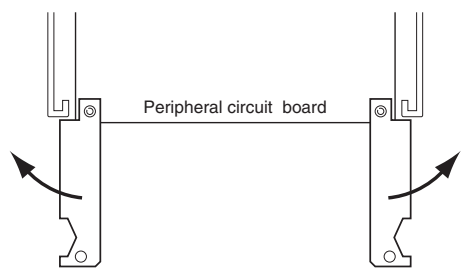

Figure 3.4.3 Dismounting Peripheral Circuit Board

(5) The jig has a magnet for keeping under the bottom plate of the case while not in use.

4 Getting Started

The S5U1C63000H6 can start using the debugger software after connecting to the host computer.

(1) Setting the DIAG switch

The S5U1C63000H6 has a self-diagnostic function at power-on.

When using this function, set the DIAG switch to ON. To skip the diagnosis, set the switch to OFF.

See Section 5.12, “Self-Diagnostic Function,” for more information on the self-diagnostic function.

(2) Turning the S5U1C63000H6 on

Turn the power switch on. The power LED (green) lights. The SLP/HLT LED (yellow) lights momentarily and goes out.

(3) Starting the debugger

Launch the debugger on the host computer. The SLP/HLT LED (yellow) lights momentarily and goes out.

(4) Executing the target program

Execute the target program from the debugger. When the target program starts running, the EMU LED (red) lights to indicate that the S5U1C63000H6 enters emulation mode. When the SLP or HALT instruction is executed, the SLP/HLT LED (yellow) lights.

(5) When a break occurs

When the target program stops at the break point set with the debugger, the EMU LED (red) goes out.

5 Operations and Functions of the S5U1C63000H6

This chapter describes operations, functions in detail and restrictions in the emulation mode of the S5U1C63000H6.

5.1 Outline of Operation

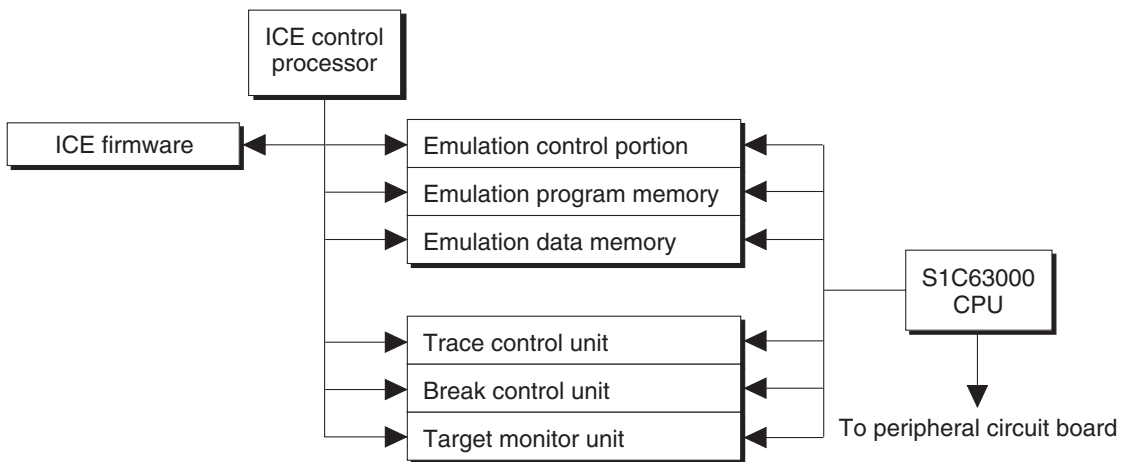

Figure 5.1.1 Function Block Diagram of the S5U1C63000H6

The S5U1C63000H6 has a processor to control in-circuit emulation, which processes the commands. The function to execute or stop target programs by the S1C63000 CPU is called emulation, and it is controlled by the emulation control unit.

The operating mode while the S1C63000 CPU is running (specified by the G command) or single stepping (specified by the S or N command) is called emulation mode. The EMU LED lights in this mode. The other status is called standby mode in which the EMU LED goes out.

The target program to be executed with the S1C63000 CPU is stored in the emulation program memory and data RAM area of the S1C63000 CPU is assigned to the emulation data memory. In the standby mode, the S5U1C63000H6 control processor loads the program from the host computer.

The trace control unit consists of a memory of 8,192 words \times 120 bits and records execution bus cycles of the S1C63000 CPU. The memory enables the register value inside the S1C63000 CPU to be real timely recorded. The program execution is traced in the emulation mode and the traced information is analyzed by the S5U1C63000H6 control processor in the standby mode.

The break control unit compares the bus condition of the S1C63000 CPU with break points and stops the execution of the target program upon coincident. The break can be also real timely made by register values of the S1C63000 CPU.

While the target program is running, the S5U1C63000H6 control processor monitors the executed program counter value of the S1C63000 CPU and RAM contents at watching points via the target monitor unit. The monitored results are displayed as on-the-fly information. The S1C63000 CPU can real timely execute the target program while the information is displayed.

5.2 Break Function

(1) Forced break

The debugger on the host computer can forced break the emulation. This function is useful when the program counter does not proceed by executing the SLP or HALT instruction in a single step process.

(2) Break commands

Some break commands are available to set various breaking condition. A break occurs when the break condition specified by the command and status of the S1C63000 CPU are met.

(3) Break by accessing to undefined area

This break occurs when the target program accesses an address exceeding the ROM capacity of the actual chip. The break is also occurred when any address other than the RAM area or mapped I/O area of the actual chip is accessed.

(4) Break by accessing write protect area

This break occurs when the target program writes data to the read only memory such as a character generator ROM. The memory contents are protected even if this break occurs.

(5) Break by incorrect stack accessing

This break occurs when the target program makes incorrectly stacking operation exceeding the defined stack area in the S1C63000 CPU.

(6) BRKIN terminal

When a signal is input to the BRKIN terminal, a break occurs at the falling edge of the signal.

5.3 Monitoring Terminals

(1) TRGOUT output terminal

A low level pulse is output at the T3 state of the clock when the trace trigger condition and the bus cycle are met.

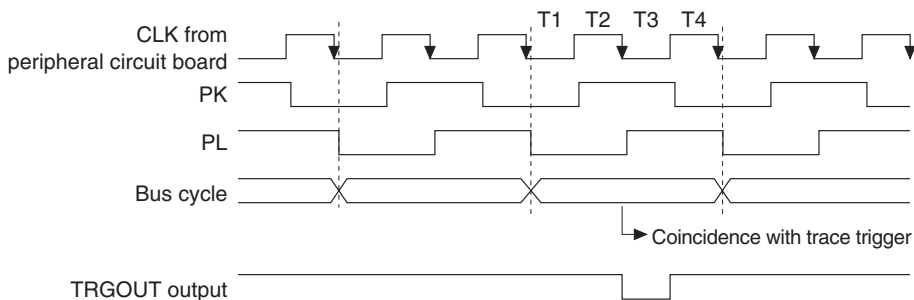

Figure 5.3.1 TRGOUT Terminal Output

(2) STOPOUT output terminal

This terminal goes low when the S1C63000 CPU is suspended (by executing of the HALT or SLP instruction). This terminal also outputs low level during a break.

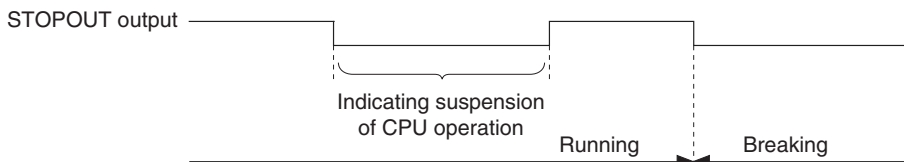

Figure 5.3.2 STOPOUT Terminal Output

(3) TRNIN input terminal

By connecting a signal line of the target system to this terminal, the signal status is stored in the trace memory as a trace information. "1" is written to the trace memory when no signal is connected or the signal goes high, or "0" is written when the signal goes low. The signal level is sampled at the rising edge of T4 state.

(4) BRKIN input terminal

A break occurs when a low level signal is input to this terminal while the target program is running. To use this terminal for the break function, the low level pulse must be 20 ms or longer. By connecting the TRGOUT output terminal to the BRKIN input terminal, breaks can be occurred according to the trace trigger conditions.

Note: The above output terminals outputs 5.0 V. The input terminals have a pull-up resistor and allow input of a signal within 3.3 V to 5.0 V.

5.4 Display During Execution and During Break

The S5U1C63000H6 control processor monitors the execution status of the S1C63000 CPU while the target program is running. It displays the S1C63000 CPU's execution status in every 500 ms when the on-the-fly display mode is specified. The program counter value that is displayed during break shows the address to be executed in the next step. The register contents displayed are the values when the previous break occurred.

5.5 Break Commands

The S5U1C63000H6 has abundant break functions.

(1) Program counter break

This break function is specified by the BP command. When the program counter of the S1C63000 CPU coincides with the specified address, a break occurs before executing the instruction. Multiple program counter values (up to maximum size of program memory) can be specified as break points.

(2) Program counter sequential break

This break function is specified by the BS command. A break occurs when the program counter of the S1C63000 CPU counts three addresses in the specified order. The pass counter can be specified for the last address. The sequence (address 1 coincidence) → (address 2 coincidence) → (address 3 counted by specified times) breaks the execution.

(3) Break by data access

This break function is specified by the BD command. A break occurs immediately after the target program accesses the data memory in the specified condition (address, data and read or write operation). It is possible to specify a range for the address condition, a mask in bit units for the data condition and a mask for the read/write condition. This specification can set one break point only.

(4) Break by register value

This break function is specified by the BR command. When the register values of the S1C63000 CPU coincide with the specified values, a break occurs immediately after the instruction is executed. A/B register, E/I/C/Z flag and X/Y register values can be specified as a break condition. It is also possible to specify masking on each register. This specification can set one break point only.

The above break functions (1, 2, 3 and 4) can be independently specified. When the target program is executed with all the BP, BS, BD and BR commands specified, a break occurs by meeting any condition.

5.6 Target Interrupt and Break

When an interrupt in the target program and a break are simultaneously occurred, the target interrupt is prioritized. The break occurs after completing the stack operation of the interrupt. The program counter at the break shows the top address of the interrupt handler routine. When the target program is restarted, it executes from the top address of the interrupt handler routine.

If an interrupt and a break are simultaneously occurred when "I" (interrupt flag) = "1" is set as a break condition by BR command, a break occurs when the "I" flag goes "1." However, the flags after the break occurred are displayed as "EICZ: 0000" (the "I" flag is reset) because of the prioritized interrupt process.

5.7 Trace Function

During running in emulation mode, information of the S1C63000 CPU (program counter, instruction code, data RAM address, data content and CPU register values) is stored into the trace memory at every CPU bus cycle. The trace memory has a capacity of 8,192 cycles, which can store the latest instructions up to 4,096 in 2 bus-cycle instruction and 2,048 in 4 bus-cycle instruction.

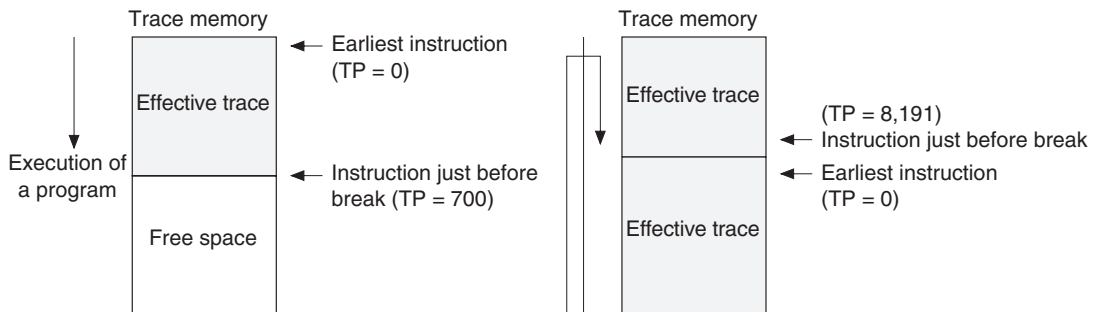

Figure 5.7.1 Trace Function

Figure 5.7.1 shows the trace function. When the trace memory becomes full, old information is erased and new information is overwritten. TP, which is called trace pointer, shows that the point of 0 means the earliest instruction and the break point means the latest information. The maximum value of the TP is 8,191.

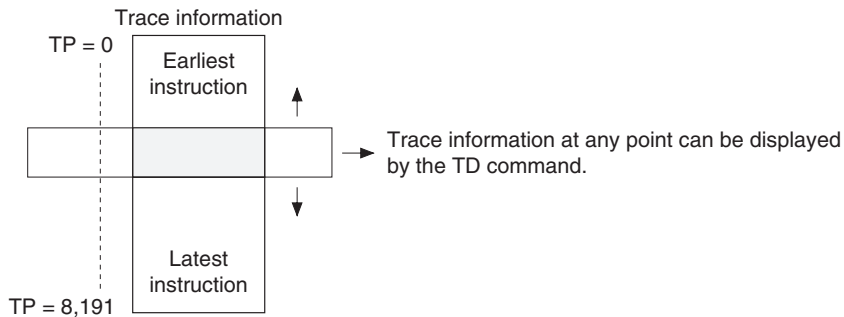

Figure 5.7.2 Trace Pointer

5.8 Trace Mode

There are following three trace modes available in the S5U1C63000H6.

(1) All bus cycle trace mode

In this trace mode, all bus cycles are traced during run emulation and step emulation until a break occurs.

(2) Specified program counter range trace mode

In this mode, bus cycles within the specified range (or outside the specified range) are traced during run emulation and step emulation until a break occurs. This function is useful for cases of tracing objective work data only or removing an WAIT routine from the trace.

(3) Single delay trigger

In this mode, starting a run emulation starts tracing for all bus cycles. When the emulation hit the trace trigger condition, the trace continues for the specified number of bus cycles, and then it stops. The trace information is displayed after a break occurs.

In the debugger, one of the above modes can be selected by the TM command.

5.9 Trace Trigger Point

In the S5U1C63000H6, a trace trigger point can be specified independent of break points. The trace trigger point is specified as the program counter conditions of the S1C63000 CPU. A low level pulse is output from the TRGOUT terminal with the timing of T3 upon coincidence of the specified value and the program counter. The information of the trace trigger point is also stored into the trace memory. In the single delay trigger mode, the trace trigger point becomes a condition for stopping the trace.

5.10 Coverage Function

The S5U1C63000H6 can retrieve and display the address information of the program accessed at the execution. The confirmation of portions whether failure analysis or debugging is completed or not can be done by checking the program through reference of the coverage information after running the program for a long time. This function is specified by the CV or CVC command.

5.11 Measurement of Execution Time

The S5U1C63000H6 has a function to measure the time from start to break of the target program or to count the number of bus cycles. This function is set by the MD command.

(1) Time measurement mode

- Range of time measurement
1 μ s to $1 \times (2^{31} - 1) \mu$ s ($\approx 2,147$ seconds ≈ 36 minutes)
- Measurement error
 $\pm 1 \mu$ s
- Units of time display
Micro second (μ s) units

(2) Bus cycle count mode

- Range of cycle measurement
1 bus cycle to $(2^{31} - 1)$ bus cycles ($= 2 \times 10^9$ bus cycles)
- Measurement error
0 cycles

5.12 Self-Diagnostic Function

The S5U1C6300H6 allows selection whether the self-diagnostic check at power on is performed or not.

(1) Disabling self-diagnostic mode (DIAG switch: OFF)

When the DIAG switch on the S5U1C63000H6 front panel is set to OFF, the S5U1C63000H6 becomes ready to accept commands without the self-diagnostic check after power on.

(2) Enabling self-diagnostic mode (DIAG switch: ON)

When the DIAG switch is set to ON, the S5U1C63000H6 executes the self-diagnostic check shown below after power on, and then it becomes ready to accept commands.

(a) ROM test

Tests the check-sum of the firmware.

(b) RAM test

Performs the read/write test of the RAM in the S5U1C63000H6.

(c) Emulation test

Tests if a break occurs normally by executing a run emulation for a few steps of instructions on the emulation memory.

When the debugger is started up after the S5U1C63000H6 is turned on with the self-diagnostic mode enabled, the S5U1C63000H6 performs diagnosis for about one minute. After that, the debugger enters command waiting status.

5.13 Restrictions on Emulation

(1) Timer operation in standby mode

In the emulation with a peripheral circuit board connected to the S5U1C63000H6, the S1C63000 CPU ordinarily idles (standby mode) as shown in Section 5.1. In the standby mode, the S5U1C63000H6 executes the monitor program and the peripheral circuit board is in stop status. The S5U1C63000H6 executes the target program by the G command and returns to the monitor program after a break occurs.

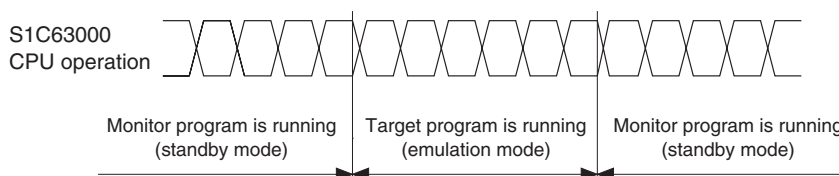

Figure 5.13.1 Operation of S1C63000 CPU

In the models with a built-in timer or watchdog timer, the timer runs only when the target program is executed if the timer is enabled. Therefore, in the single step operation, the S1C63xxx timer cannot count in real time.

(2) Interrupt in standby mode

In the standby mode, interrupt requests from the target system is reserved. The interrupt while the monitor program is being executed is accepted at the execution of the target program. For instance, when an interrupt request from the target system is generated while breaking, the interrupt will be accepted immediately after the target program restarts if the interrupt is enabled in the S1C63000 CPU.

(3) Interrupt at single step operation

Interrupts during single step operation can be enabled or disabled using the MD command. Each operation is as follows.

When interrupt is enabled

If an interrupt request is generated while the target program is single stepping by the S or N command, the interrupt processing will be started when an instruction is executed, and the execution stops after fetching the vector address of the interrupt. Therefore, the next single step operation executes the interrupt handler routine. When the HALT or SLP instruction is executed by the S or N command, the execution is not terminated until an interrupt occurs. In this status, a forced break input from the host computer can suspend the execution.

When interrupt is disabled

An interrupt processing is not executed by the S command. Therefore, the execution of the HALT or SLP instruction is immediately suspended, and the program counter indicates the address next to the HALT or SLP instruction. The N command operates similar to the S command in the execution of the main routine. However, it enables interrupts while a sub routine is being executed regardless of whether the MD command enables interrupts or not.

(4) Data read from undefined RAM area

When a data RAM (ROM) area or an I/O area that is not available in the actual IC chip is read, the read data becomes indefinite. Read data from the actual IC is also indefinite, however it is different from the S5U1C63000H6.

(5) Detection of SP1 incorrect stack access

It is possible to detect any incorrect stack access to out of the SP1 area by specifying the SP1 area with the BSP command.

The S1C63000 CPU has a queue register and takes stack values in advance in order to make high speed process of the stacking operation for the CALR instruction and interrupts. Therefore, when restoring a value from the top address of the stack, the S1C63000 CPU takes a value beyond the top address and writes it into the queue register. This operation works without any problem. However, the queue register has an indefinite value. In order not to make this process incorrect access, add three to the top address of the SP1 area when specifying.

(6) Data read break

Executing the "INT *addr6*" instruction issues a dummy read cycle for the memory specified with the *addr6* operand. Therefore, a break caused by the dummy read will occur at this instruction when a data read break condition has been specified by the BD command.

(7) Register (data) break

The register (data) value after a break occurs may differ from the value set as a register (data) break condition.

The following shows an example if a break condition has been set so that a break will occur when the A register is set to 5, and when the S1C63000 CPU has executed the sequence in the timing chart shown below to set the A register to 5 and 6:

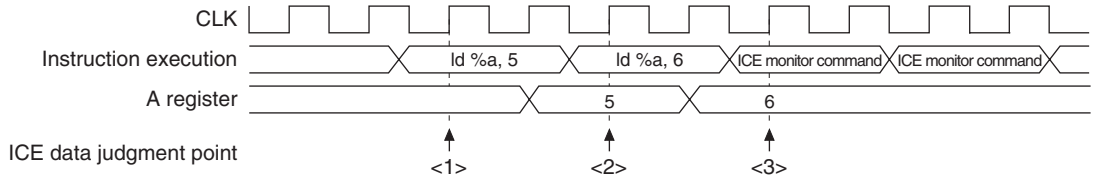

Figure 5.13.2 Example of Register Break

The S5U1C63000H6 judges the register data at the points indicated with a “↑.” It judges that the A register is “5” at the point of <2>, and the register break condition is met at the same time. However, the S1C63000 CPU is executing the following “ld %a, 6” instruction at this point and the break occurs after the A register is set to “6.” Therefore, “6” is read from the A register after the break has occurred. This is also applied to the break by accessing to undefined area function.

(8) Register (data) break and hardware interrupt

If a hardware interrupt occurs when the register (data) break condition described in Item (7) is met, register (data) break will occur at the top address of the interrupt handler routine. The following shows an example when a hardware interrupt factor occurs while the S1C63000 CPU is executing the sequence in the timing chart shown below to set the A register to 5 and 6, if a break condition has been set so that a register break will occur when the A register is set to 5:

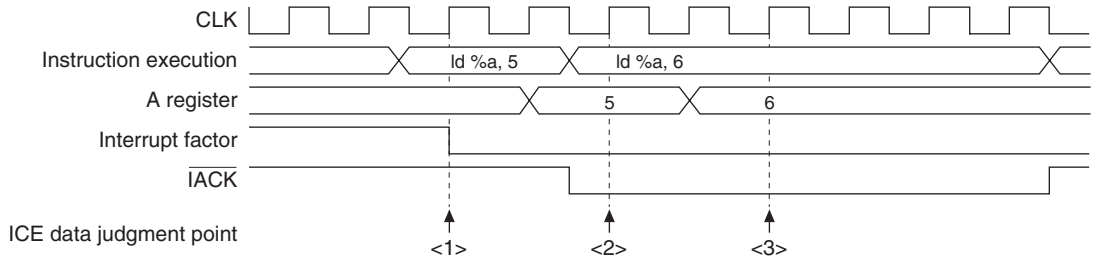

Figure 5.13.3 Example When a Register Break and an Interrupt Occur Simultaneously

In the timing chart above, if an interrupt factor occurs (falling edge) at the point of <1>, the S1C63000 CPU outputs the IACK signal to indicate that an interrupt acknowledgment cycle is executed. The interrupt processing cannot be stopped while IACK is at low level. Therefore, the S5U1C63000H6 cannot disable the interrupt even if the register break condition (A register = “5”) is met at the point of <2>, as IACK is at low level. The register break will occur after jumping to the interrupt vector address.

6 LCD Driver

The S5U1C63000H6 has an LCD driver for emulating built-in LCD driver models.

Note, however, that some functions supported with the S5U1C63000H6 may not be available in the model to be used. For details of the LCD driver functions, refer to the technical manual for each model.

6.1 Differences from Actual IC

Be aware that there are differences on the functions and characteristics from those of the actual IC as shown below. If they are not taken into consideration, the program may not be operated properly on the actual IC even if there is no problem on the S5U1C63000H6 with the LCD driver.

(1) Initialization

In the actual IC, contents of the LCD segment memory are indefinite at system reset and the output LCD drive waveform is also indefinite according to the memory contents. It means that the segment memory and the LCD drive waveforms are coincident even though both are indefinite. However, in the S5U1C63000H6, the segment memory and the output LCD drive waveform are not coincident. Therefore, be sure to create the initial routine so that the LCD segment memory will be cleared (or set) after a system reset.

(2) LCD segment RAM (for models in which the memory-bit assignment for the LCD segments is fixed)

In the actual IC, when reading a segment memory address that contains both the bits assigned for the LCD segments and the bits not assigned, the unassigned bits are always read as "0." However, in the S5U1C63000H6, the unassigned bits in the segment memory can be read and written as memory bits. Therefore, the program must ignore these unassigned bit values when a segment memory word is read out.

(3) Drive capability of SEG and COM terminals

The output drive capability of the SEG and COM terminals in the S5U1C63000H6 is different from that of the actual IC. The S5U1C63000H6 cannot be used for evaluating electrical characteristics. The system should be designed in consideration of the electrical characteristics described in the technical manual of each model.

(4) LCD drive voltage

The LCD drive voltage in the S5U1C63000H6 may differ from that of the actual IC.

6.2 Connection with the Target System

Use the supplied connection cables (100-pin/50-pin × 2 flat type, 34-pin flat type) to connect between the S5U1C63000H6 and the LCD connectors on the target board.

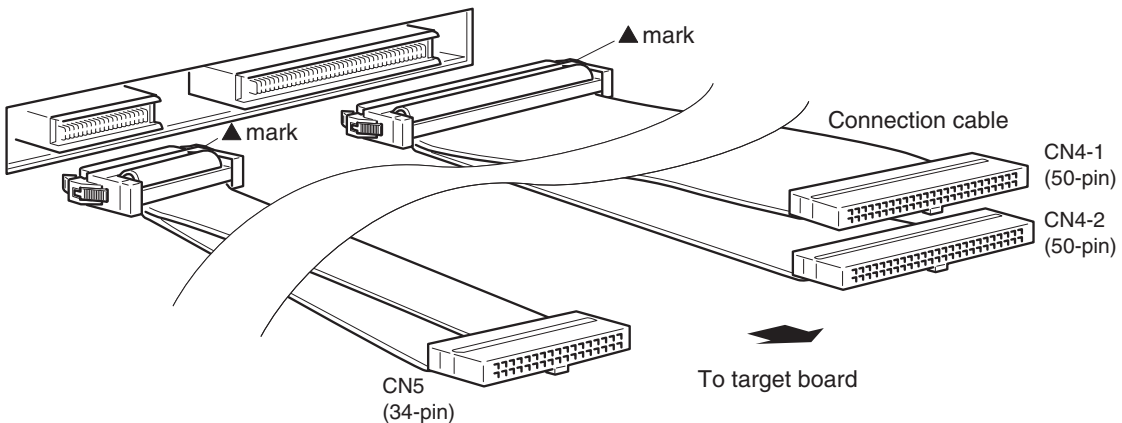

Figure 6.2.1 Connecting with the Target System

Connector pin assignments

Table 6.2.1 LC1 Connector (100-pin/50-pin × 2 flat type)

LC1 connector (CN4-1)		LC1 connector (CN4-2)	
No.	Signal name	No.	Signal name
1	COM0	1	SEG42
2	COM1	2	SEG43
3	COM2	3	SEG44
4	COM3	4	SEG45
5	COM4	5	SEG46
6	COM5	6	SEG47
7	COM6	7	SEG48
8	COM7	8	SEG49
9	SEG0	9	SEG50
10	SEG1	10	SEG51
11	SEG2	11	SEG52
12	SEG3	12	SEG53
13	SEG4	13	SEG54
14	SEG5	14	SEG55
15	SEG6	15	SEG56
16	SEG7	16	SEG57
17	SEG8	17	SEG58
18	SEG9	18	SEG59
19	SEG10	19	SEG60
20	SEG11	20	SEG61
21	SEG12	21	SEG62
22	SEG13	22	SEG63
23	SEG14	23	SEG64
24	SEG15	24	SEG65
25	SEG16	25	SEG66
26	SEG17	26	SEG67
27	SEG18	27	SEG68
28	SEG19	28	SEG69
29	SEG20	29	SEG70
30	SEG21	30	SEG71
31	SEG22	31	SEG72
32	SEG23	32	SEG73
33	SEG24	33	SEG74
34	SEG25	34	SEG75
35	SEG26	35	SEG76
36	SEG27	36	SEG77
37	SEG28	37	SEG78
38	SEG29	38	SEG79
39	SEG30	39	Cannot be connected
40	SEG31	40	Cannot be connected
41	SEG32	41	Cannot be connected
42	SEG33	42	Cannot be connected
43	SEG34	43	Cannot be connected
44	SEG35	44	Cannot be connected
45	SEG36	45	Cannot be connected
46	SEG37	46	Cannot be connected
47	SEG38	47	Cannot be connected
48	SEG39	48	Cannot be connected
49	SEG40	49	Cannot be connected
50	SEG41	50	Cannot be connected

Table 6.2.2 LC2 Connector (34-pin flat type)

LC2 connector (CN5)	
No.	Signal name
1	COM0
2	COM1
3	COM2
4	COM3
5	COM4
6	COM5
7	COM6
8	COM7
9	COM8
10	COM9
11	COM10
12	COM11
13	COM12
14	COM13
15	COM14
16	COM15
17	COM16
18	COM17
19	COM18
20	COM19
21	COM20
22	COM21
23	COM22
24	COM23
25	COM24
26	COM25
27	COM26
28	COM27
29	COM28
30	COM29
31	COM30
32	COM31
33	Cannot be connected
34	Cannot be connected

Note that some signals do not exist in the actual IC depending on the model.

The COM0–COM7 pins are available in the both connectors CN4-1 and CN5, and either one can be used.

7 Notes on Use

Pay attention to the following matters for proper use of the S5U1C63000H6.

7.1 Notes on Operations

(1) Connecting and disconnecting the units

Make sure that the S5U1C63000H6 is turned off when installing the peripheral circuit board (S5U1C63xxxP) and connecting/disconnecting the cables, as hot insertion/removal may damage the IC.

(2) Turning power on and off

When turning the S5U1C63000H6 off and on again, wait at least 10 seconds before turning on. If power is turned on without an interval, the power-on-reset sequence may not be executed normally and the result is that the S5U1C63000H6 fails to function normally, or the circuit breaker on the S5U1C63000H6 may trip.

(3) Peripheral circuit board (S5U1C63xxxP)

A peripheral circuit board is required to operate the S5U1C63000H6. The S5U1C63000H6 package does not include a peripheral circuit board, so it must be prepared separately. If the S5U1C63000H6 is turned on without a peripheral circuit board installed, the “SLP/HLT” LED on the S5U1C63000H6 front panel lights.

(4) Over current protection

If the S5U1C63000H6 is turned on when V_{DD} and V_{SS} are short-circuited on the target system, the over current protection function of the dedicated AC adapter works to cut off its output current and the power LED does not light. The circuit breaker cuts the power at the load current of 3 A or more on the target system.

7.2 Differences from Actual IC

(1) Initialization of RAM

The data RAM of the actual IC is not initialized at system reset, however, the S5U1C63000H6 initializes the RAM with “0A.” Therefore, be sure to initialize the RAM in the target program, and do not create a program depending on the initial value.

(2) Initialization of registers

In the actual IC, the CPU registers are not initialized at power on. At initial reset, they keep values prior to the reset except the program counter (PC), the interrupt flag (I) and the extension flag (E). However, the CPU registers in the S5U1C63000H6 are initialized to “0A” (4-bit), “0AA” (8-bit) and “0AAAA” (16-bit) at the power on and at a software reset by the debugger command. Therefore, be sure to initialize the registers, and do not create a program depending on the initial value. The reset switch on the peripheral circuit board and the hardware reset input from the I/O connector keep values prior to the reset the same as the actual IC.

(3) Access to undefined area

In the S5U1C63000H6, a break occurs if an undefined area is accessed. However, a RAM is included in the undefined area and an undefined area break occurs after the area has been accessed, so any data can be written to the undefined area. When the target program is restarted after an undefined area break has occurred, it works using a memory area that does not exist in the actual IC. Therefore, be sure to avoid reading/writing from/to undefined area by the target program.

(4) Data dump

The S5U1C63000H6 uses a peripheral circuit board clock for accessing a RAM, ROM, LCD or I/O area with a data dump command. Therefore, the value of the I/O area read in the target program may differ from the value read by a dump command, when an I/O area that develops a delay until the correct value is obtained due to the parasitic capacitance and the pull-up/down resistor of the I/O terminal.

8 Maintenance and Warranty

8.1 Self-Diagnostic Test

The self-diagnostic test is executed by starting the debugger after setting the DIAG switch on the front panel to “ON” position and then turning the S5U1C63000H6 on.

The debugger displays the messages shown below during the start-up sequence.

```
Debugger for S1C63 Ver. x.xx
Copyright (C) SEIKO EPSON CORP. 1998-xxxx

Connecting USB ... done
DIAG test, please wait 1 min ... done    ← <I>
Parameter file name      : Par63xxx.par
          Version        : xx
          Chip name      : xxxxxx
CPU version              : x.x
PRC board version       : x.x
LCD board version       : x.x
EXT board version       : x.x
ICE hardware version    : x.x
ICE software version    : x.x
DIAG test                : OK.
Map ..... done
Initialize ..... done
>
```

When an error is detected in the diagnosis, the error message is displayed at the point <I> instead of “done.”

If an error message is displayed, stop using the S5U1C63000H6, as it may have a hardware failure.

This self-diagnostic test takes about one minute for its precise inspection until it is completed and the S5U1C63000H6 is ready to accept commands.

8.2 Warranty

Please refer to the warranty card included in the package for the warranty details.

9 Troubleshooting

Following shows some hardware errors and their possible causes.

(1) A message of “connecting USB ... failure” is displayed at start-up of the debugger.

- Is power of the S5U1C63000H6 on?
- Is the circuit breaker (CB) off?
- Is the host cable connected correctly?
- Is the target cable connected correctly?
- Is the peripheral circuit board insert firmly?

(2) The circuit breaker (CB) trips and the POWER LED goes out when the S5U1C63000H6 is turned on.

- Is the target cable connected correctly?
- Is V_{DD} and V_{SS} short-circuited on the target board?

Refer to the “S5U1C63000A Manual” for operations of the debugger.



International Sales Operations

AMERICA

EPSON ELECTRONICS AMERICA, INC.

214 Devcon Drive,
San Jose, CA 95112, USA
Phone: +1-800-228-3964 FAX: +1-408-922-0238

EUROPE

EPSON EUROPE ELECTRONICS GmbH

Riesstrasse 15, 80992 Munich,
GERMANY
Phone: +49-89-14005-0 FAX: +49-89-14005-110

ASIA

EPSON (CHINA) CO., LTD.

7F, Jinbao Bldg., No.89 Jinbao St.,
Dongcheng District,
Beijing 100005, CHINA
Phone: +86-10-8522-1199 FAX: +86-10-8522-1125

SHANGHAI BRANCH

7F, Block B, Hi-Tech Bldg., 900 Yishan Road,
Shanghai 200233, CHINA
Phone: +86-21-5423-5577 FAX: +86-21-5423-4677

SHENZHEN BRANCH

12F, Dawning Mansion, Keji South 12th Road,
Hi-Tech Park, Shenzhen 518057, CHINA
Phone: +86-755-2699-3828 FAX: +86-755-2699-3838

EPSON HONG KONG LTD.

Unit 715-723, 7/F Trade Square, 681 Cheung Sha Wan Road,
Kowloon, Hong Kong.
Phone: +852-2585-4600 FAX: +852-2827-4346

EPSON TAIWAN TECHNOLOGY & TRADING LTD.

14F, No. 7, Song Ren Road,
Taipei 110, TAIWAN
Phone: +886-2-8786-6688 FAX: +886-2-8786-6660

EPSON SINGAPORE PTE., LTD.

1 HarbourFront Place,
#03-02 HarbourFront Tower One, Singapore 098633
Phone: +65-6586-5500 FAX: +65-6271-3182

SEIKO EPSON CORP.

KOREA OFFICE

5F, KLI 63 Bldg., 60 Yoido-dong,
Youngdeungpo-Ku, Seoul 150-763, KOREA
Phone: +82-2-784-6027 FAX: +82-2-767-3677

SEIKO EPSON CORP.

MICRODEVICES OPERATIONS DIVISION

IC Sales & Marketing Department

421-8, Hino, Hino-shi, Tokyo 191-8501, JAPAN
Phone: +81-42-587-5814 FAX: +81-42-587-5117

S5U1C63000H6 Manual
(S1C63 Family In-Circuit Emulator)

SEIKO EPSON CORPORATION