

• General Description

The AGM1095MA combines advanced trench MOSFET technology with a low resistance package to provide extremely low $R_{DS(ON)}$.

This device is ideal for load switch and battery protection applications.

• Features

- Advance high cell density Trench technology
- Low $R_{DS(ON)}$ to minimize conductive loss
- Low Gate Charge for fast switching
- Low Thermal resistance
- 100% Avalanche tested
- 100% DVDS tested

• Application

- MB/VGA Vcore
- SMPS 2nd Synchronous Rectifier
- POL application
- BLDC Motor driver

Product Summary

BVDSS	RDSON	ID
100V	120mΩ	10A
-100V	150mΩ	-13A

PDFN5*6 Pin Configuration

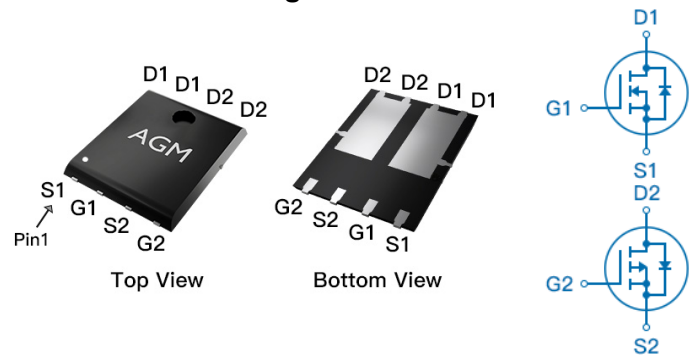

Package Marking and Ordering Information

Device Marking	Device	Device Package	Reel Size	Tape width	Quantity
AGM1095MA	AGM1095MA	PDFN5*6	330mm	12mm	3000

Table 1. Absolute Maximum Ratings (TA=25°C)

Symbol	Parameter	Rating		Units
		N-Ch	P-Ch	
V_{DS}	Drain-Source Voltage ($V_{GS}=0V$)	100	-100	V
V_{GS}	Gate-Source Voltage ($V_{DS}=0V$)	±20	±20	V
I_D	Drain Current-Continuous($T_A=25^\circ C$)	2.7	-2.5	A
	Drain Current-Continuous($T_c=25^\circ C$) (Note 1)	10	-13	A
	Drain Current-Continuous($T_c=100^\circ C$)	8.0	-9.0	A
IDM (pulse)	Drain Current-Pulsed (Note 2)	30	-39	A
P_D	Total Power Dissipation($T_A=25^\circ C$)	2.5	2.5	W
	Total Power Dissipation($T_c=25^\circ C$)	33.7	32	W
	Total Power Dissipation($T_c=100^\circ C$)	13.5	12.8	W
EAS	Avalanche energy (Note 3)	90	110	mJ
TJ,TSTG	Operating Junction and Storage Temperature Range	-55 To 150	-55 To 150	°C

Table 2. Thermal Characteristic

Symbol	Parameter	Typ	Max	Unit
$R_{\theta JA}$	Thermal Resistance Junction-ambient (Steady State) ¹	20	20	°C/W
$R_{\theta JC}$	Thermal Resistance Junction-Case ¹	3.7	3.9	°C/W

Table 3. N- Channel Electrical Characteristics (T_J=25°C unless otherwise noted)

Symbol	Parameter	Conditions	Min	Typ	Max	Unit
On/Off States						
BVDSS	Drain-Source Breakdown Voltage	VGS=0V ID=250μA	100	--	--	V
IDSS	Zero Gate Voltage Drain Current	VDS=100V,VGS=0V	--	--	1	μA
IGSS	Gate-Body Leakage Current	VGS=±20V,VDS=0V	--	--	±100	nA
VGS(th)	Gate Threshold Voltage	VDS=VGS,ID=250μA	1.2	--	2.2	V
gFS	Forward Transconductance	VDS=5V,ID=3A	--	7	--	S
RDS(on)	Drain-Source On-State Resistance	VGS=10V, ID=6A	--	120	140	mΩ
		VGS=4.5V, ID=3A	--	140	160	mΩ
Dynamic Characteristics						
Ciss	Input Capacitance	VDS=40V,VGS=0V, F=1MHZ	--	999	--	pF
Coss	Output Capacitance		--	46	--	pF
Crss	Reverse Transfer Capacitance		--	32	--	pF
Rg	Gate resistance	VGS=0V, VDS=0V,f=1.0MHz	--	--	--	Ω
Switching Times						
td(on)	Turn-on Delay Time	VGS=10V,VDS=30V, RL=15Ω,RGEN=2.5Ω	--	50	--	nS
tr	Turn-on Rise Time		--	2.9	--	nS
td(off)	Turn-Off Delay Time		--	17.3	--	nS
tf	Turn-Off Fall Time		--	2.8	--	nS
Qg	Total Gate Charge	VGS=10V, VDS=30V, ID=3A	--	25.4	--	nC
Qgs	Gate-Source Charge		--	4.2	--	nC
Qgd	Gate-Drain Charge		--	4.3	--	nC
Source-Drain Diode Characteristics						
ISD	Source-Drain Current(Body Diode)		--	--	10	A
VSD	Forward on Voltage	VGS=0V,IS=6A	--	--	1.2	V
trr	Reverse Recovery Time	IF=6A , dI/dt=100A/μs , TJ=25°C	--	--	--	ns
Qrr	Reverse Recovery Charge		--	--	--	nc

Notes 1.The maximum current rating is package limited.

Notes 2.Repetitive Rating: Pulse width limited by maximum junction temperature

Notes 3.EAS condition: T_J=25°C

Table 3. P-Channel Electrical Characteristics (T_J=25°C unless otherwise noted)

Symbol	Parameter	Conditions	Min	Typ	Max	Unit
On/Off States						
BVDSS	Drain-Source Breakdown Voltage	VGS=0V ID=-250μA	-100	--	--	V
IDSS	Zero Gate Voltage Drain Current	VDS=-100V,VGS=0V	--	--	-1	μA
IGSS	Gate-Body Leakage Current	VGS=±20V,VDS=0V	--	--	±100	nA
VGS(th)	Gate Threshold Voltage	VDS=VGS,ID=-250μA	-1.2	-1.6	-2.2	V
gFS	Forward Transconductance	VDS=-5V,ID=-3A	--	7	--	S
RDS(on)	Drain-Source On-State Resistance	VGS=-10V, ID=-6A	--	150	200	mΩ
		VGS=-4.5V, ID=-3A	--	200	250	mΩ
Dynamic Characteristics						
Ciss	Input Capacitance	VDS=-50V,VGS=0V, F=1MHZ	--	1620	--	pF
Coss	Output Capacitance		--	86	--	pF
Crss	Reverse Transfer Capacitance		--	40	--	pF
Rg	Gate resistance	VGS=0V, VDS=0V,f=1.0MHz	--	1.2	--	Ω
Switching Times						
td(on)	Turn-on Delay Time	VGS=-10V,VDS=-50V, ID=-10A, RGEN=3.3Ω	--	12	--	nS
tr	Turn-on Rise Time		--	152	--	nS
td(off)	Turn-Off Delay Time		--	28	--	nS
tf	Turn-Off Fall Time		--	38	--	nS
Qg	Total Gate Charge	VGS=-10V, VDS=-50V, ID=-12A	--	33	--	nC
Qgs	Gate-Source Charge		--	4.3	--	nC
Qgd	Gate-Drain Charge		--	7.2	--	nC
Source-Drain Diode Characteristics						
ISD	Source-Drain Current(Body Diode)		--	--	-13	A
VSD	Forward on Voltage	VGS=0V,IS=-6A	--	--	-1.2	V
trr	Reverse Recovery Time	IF=-6A , dI/dt=100A/μs , TJ=25°C	--	--	--	ns
Qrr	Reverse Recovery Charge		--	--	--	nc

Notes 1.The maximum current rating is package limited.

Notes 2.Repetitive Rating: Pulse width limited by maximum junction temperature Notes

3.EAS condition: T_J=25°C

N- Channel 100V MOSFET

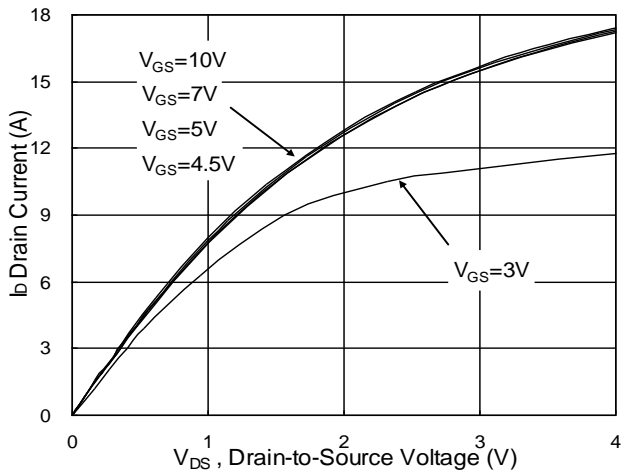

Fig.1 Typical Output Characteristics

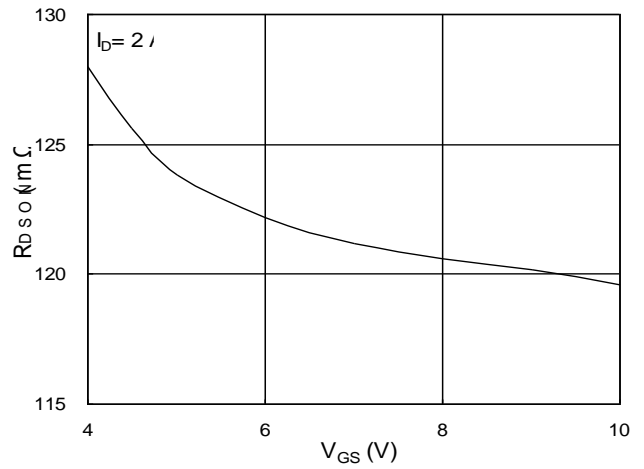

Fig.2 On-Resistance vs. Gate-Source

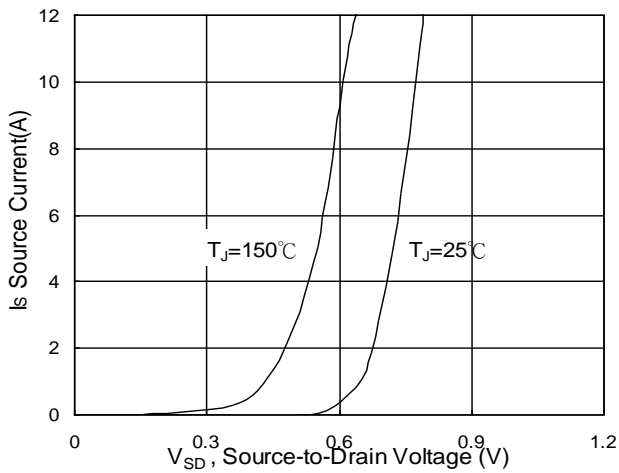

Fig.3 Forward Characteristics Of Reverse

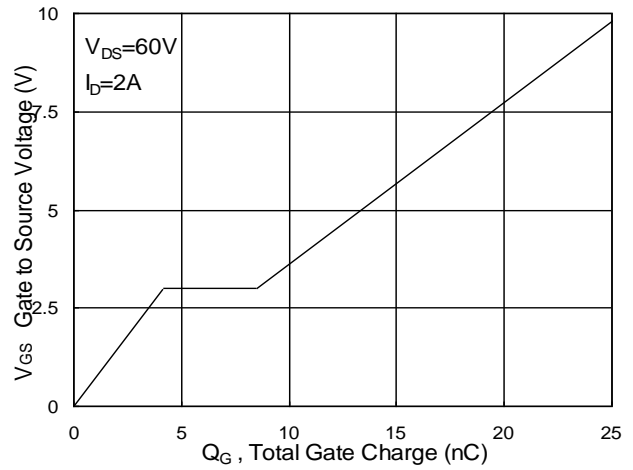
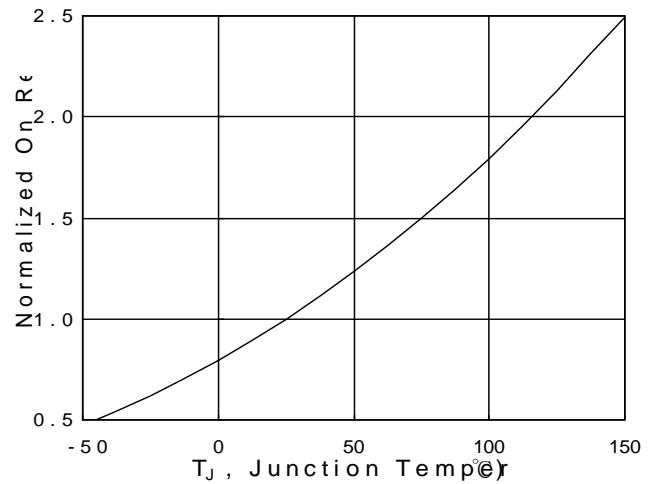
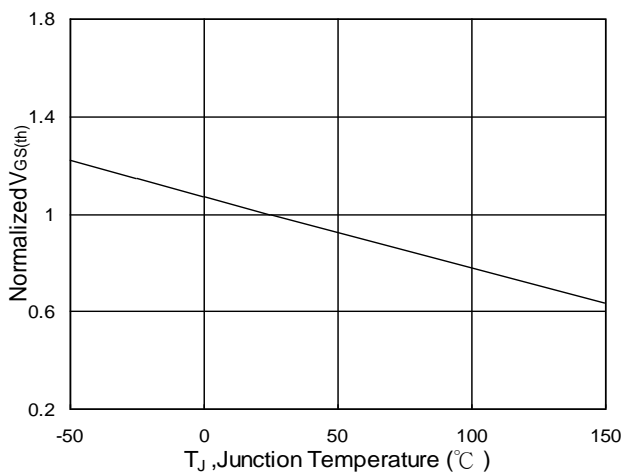

Fig.4 Gate-Charge Characteristics



N- Channel 100V MOSFET

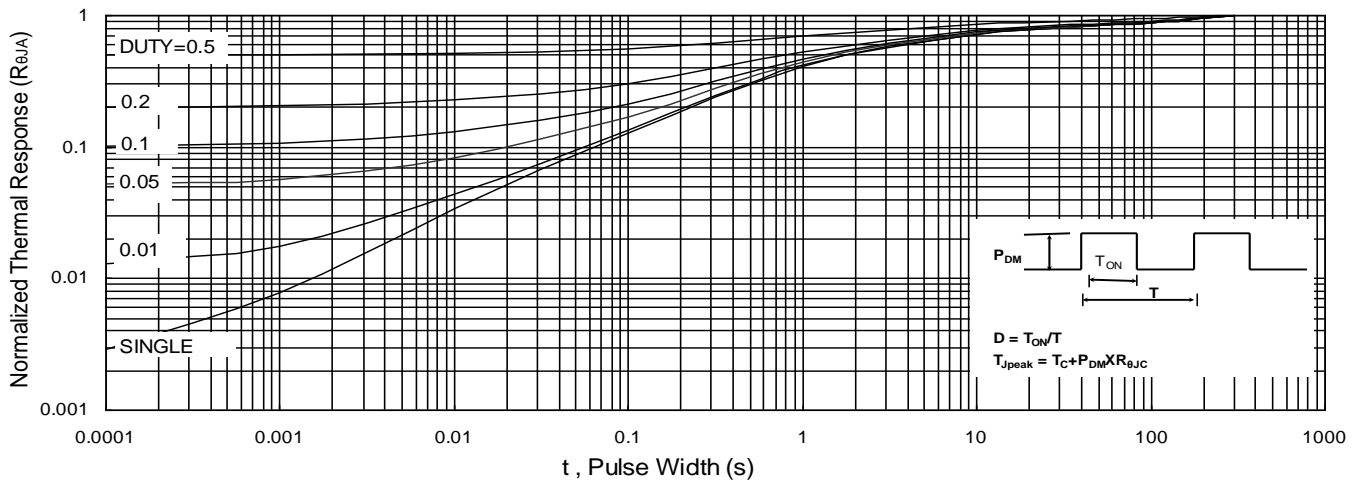
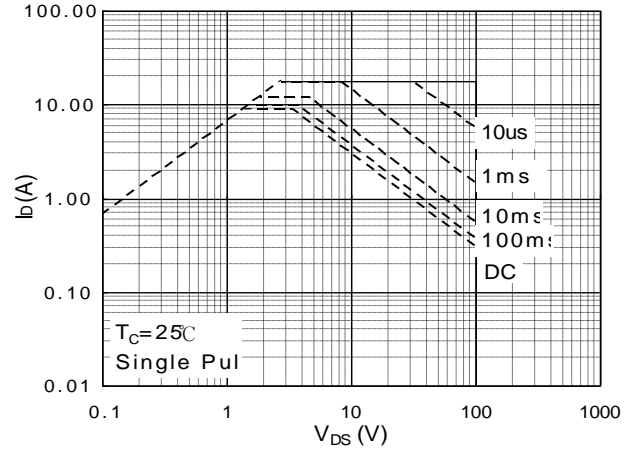
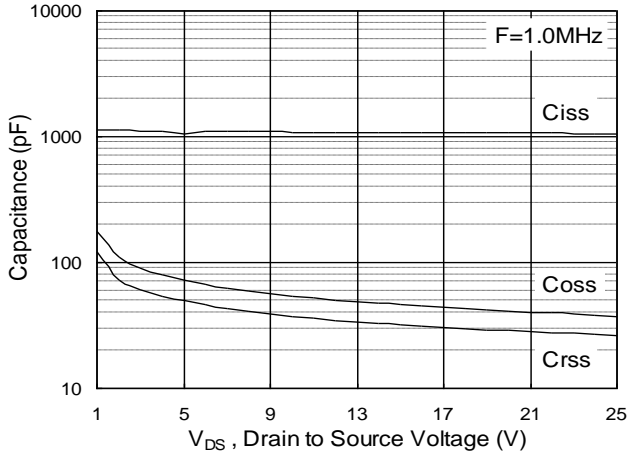
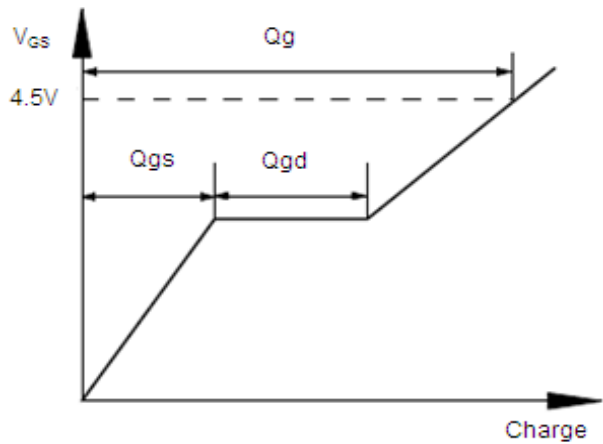
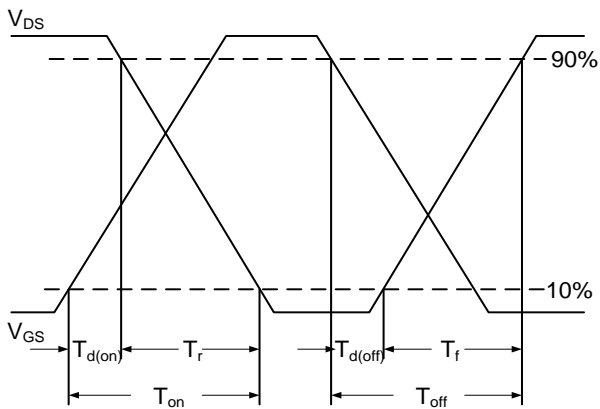
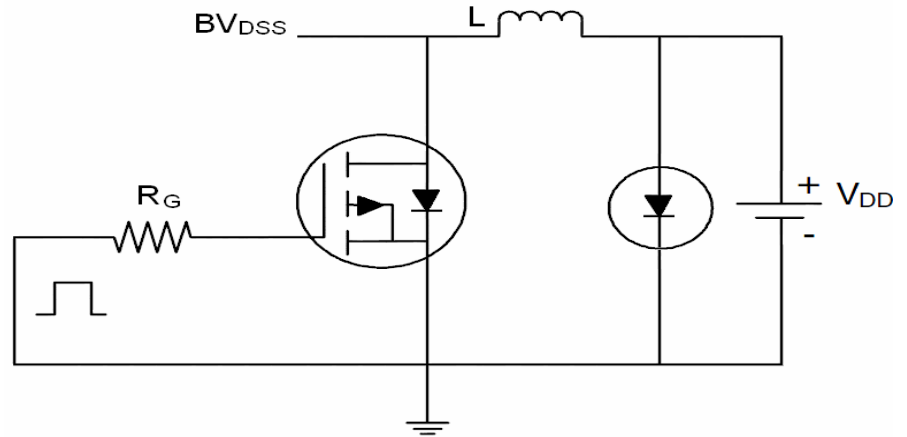
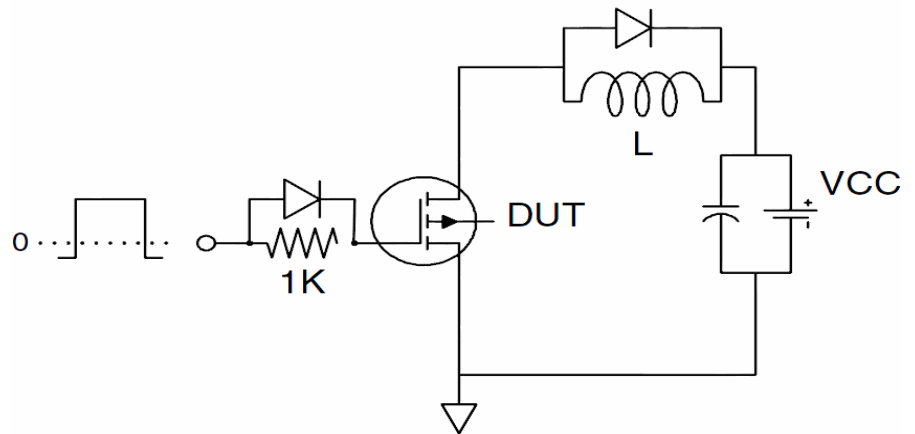
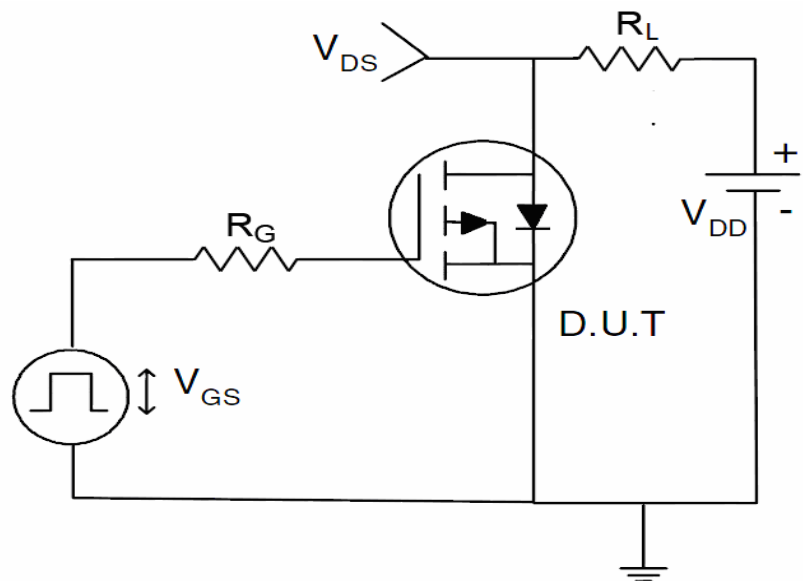
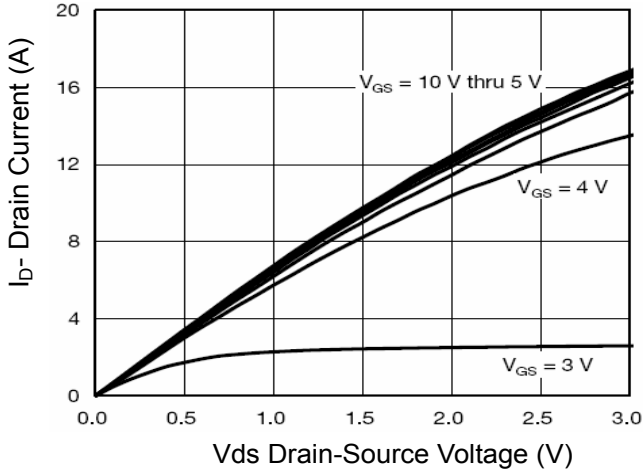
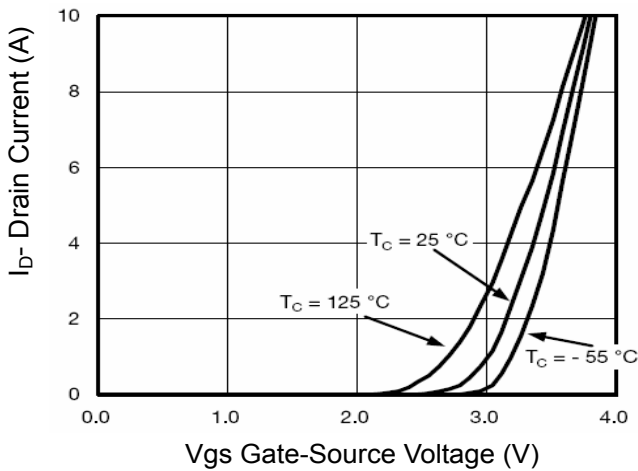
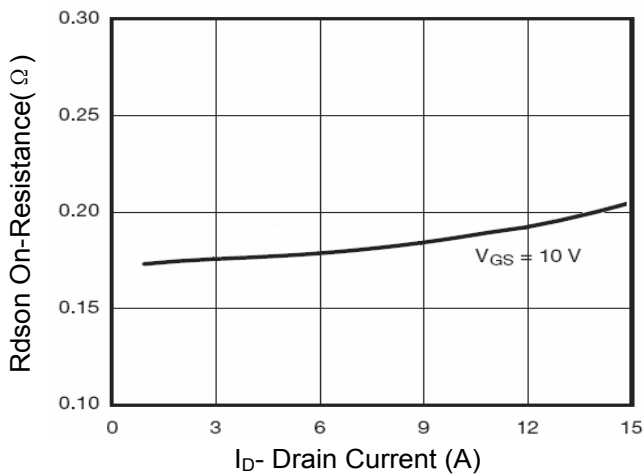
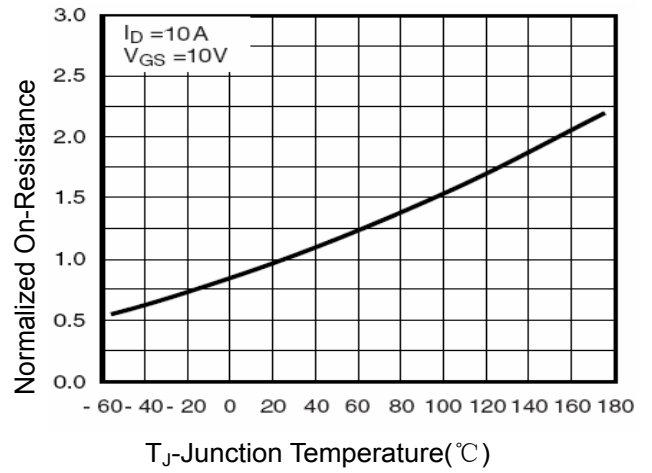
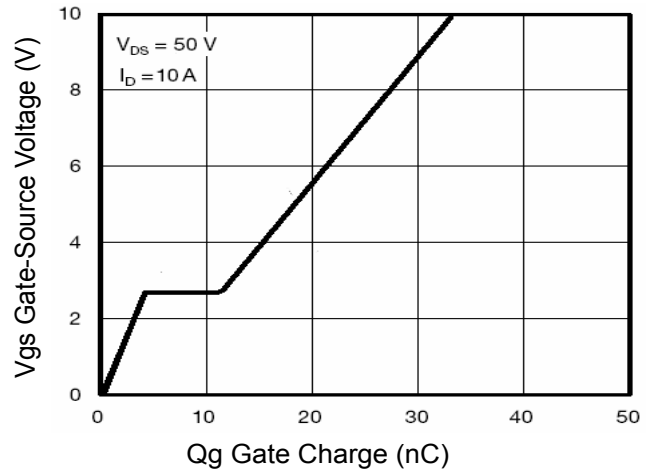
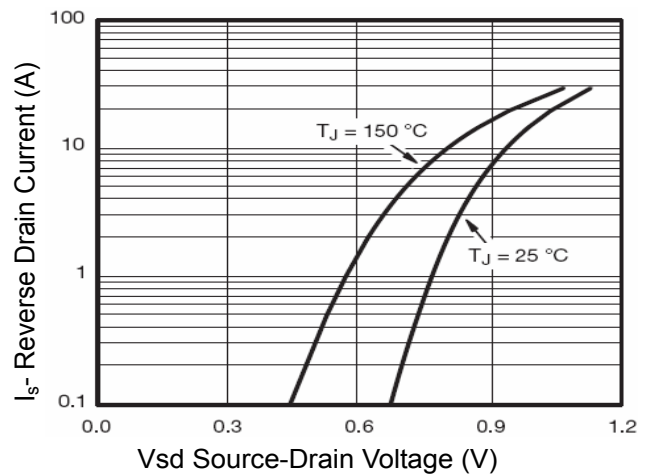
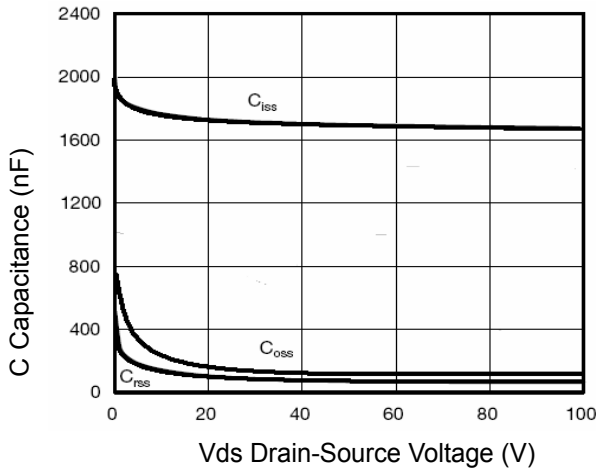
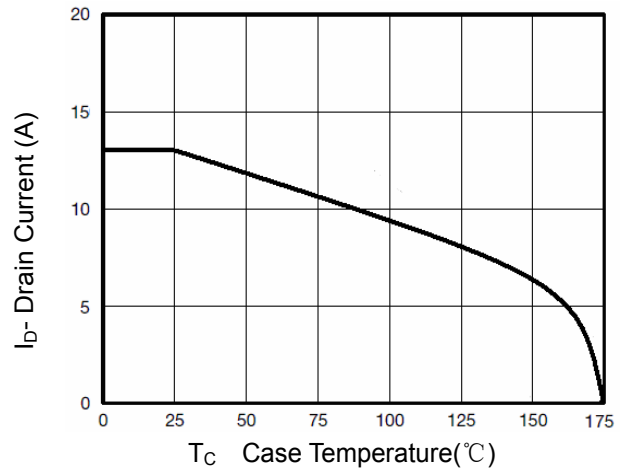
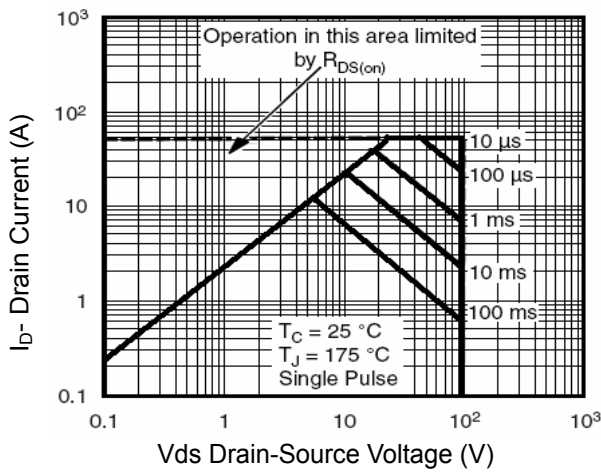
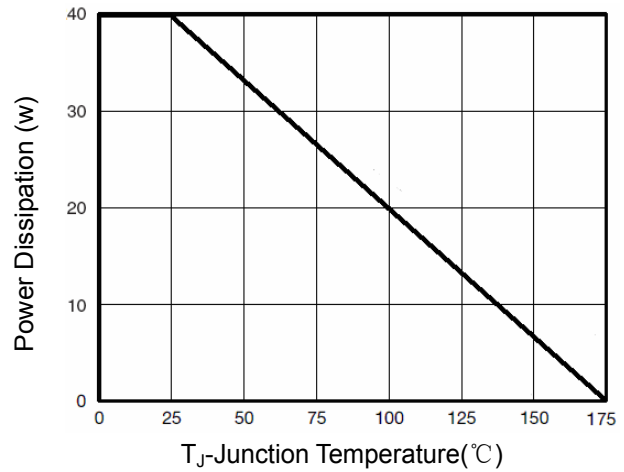
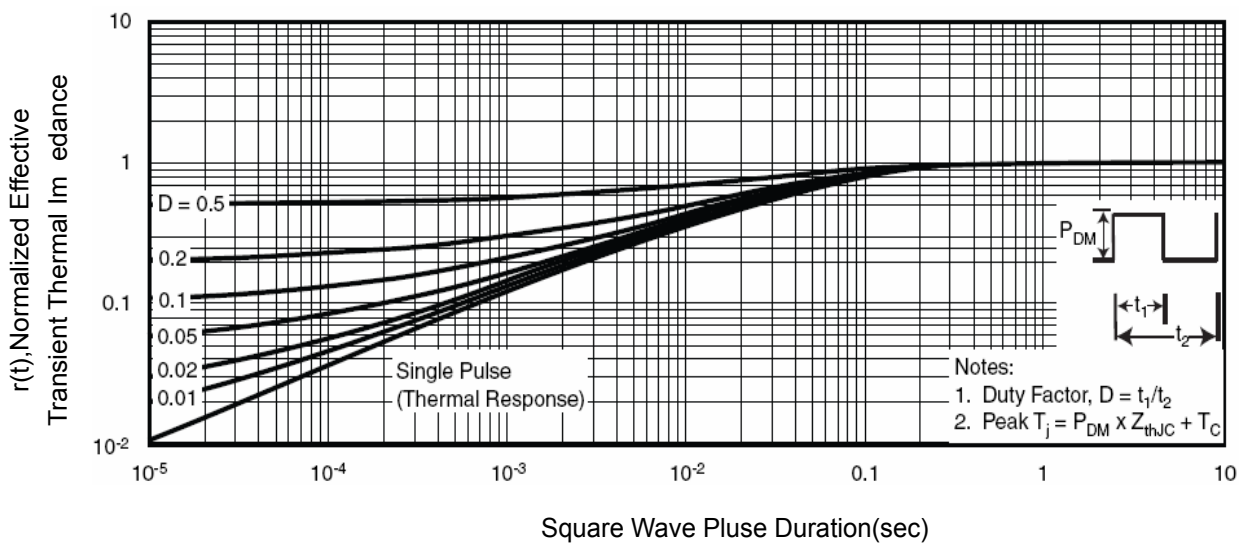

Fig.9 Normalized Maximum Transient Thermal Impedance



P- Channel 100V MOSFET
Test Circuit
1) E_{AS} Test Circuit

2) Gate Charge Test Circuit

3) Switch Time Test Circuit

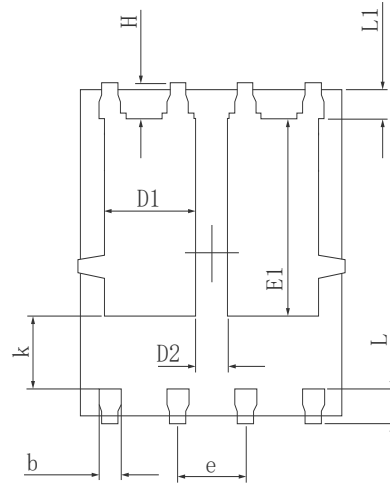
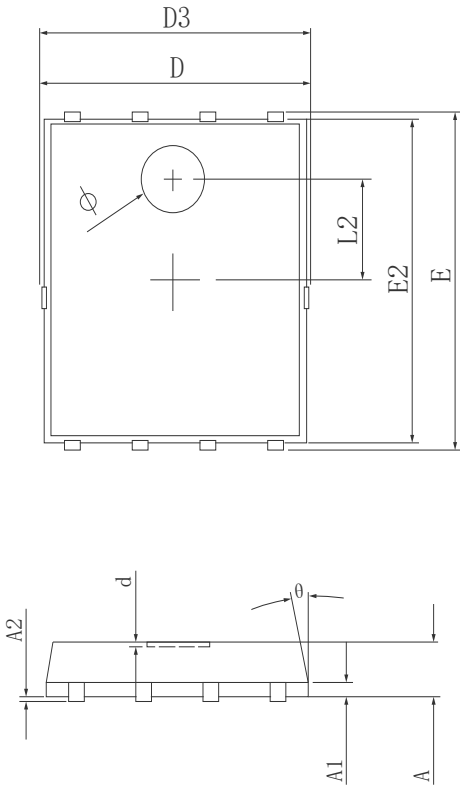
P- Channel 100V MOSFET
Typical Electrical and Thermal Characteristics (Curves)

Figure 1 Output Characteristics

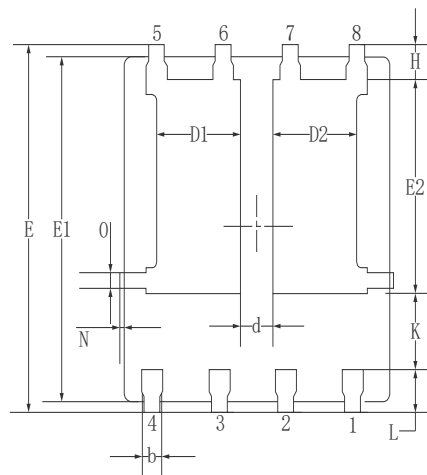
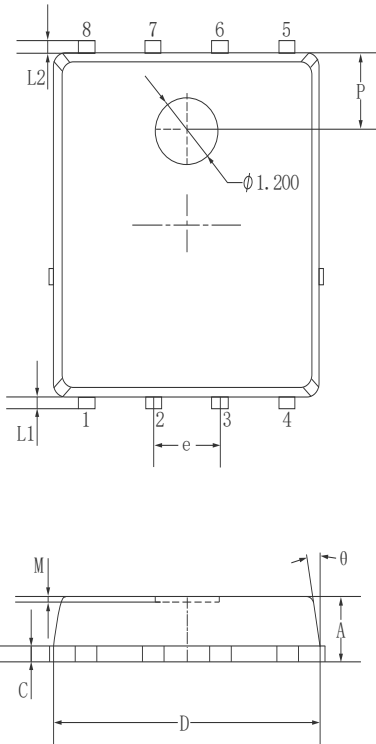
Figure 2 Transfer Characteristics

Figure 3 Rdson- Drain Current

Figure 4 Rdson-Junction Temperature

Figure 5 Gate Charge

Figure 6 Source- Drain Diode Forward

P- Channel 100V MOSFET

Figure 7 Capacitance vs Vds

Figure 9 Drain Current vs Case Temperature

Figure 8 Safe Operation Area

Figure 10 Power De-rating

Figure 11 Normalized Maximum Transient Thermal Impedance

•Dimensions (PDFN5*6)

SYMBOL	MILLIMETER		
	MIN	Typ.	MAX
A	0.900	1.000	1.100
A1	0.254 REF.		
A2	0°0.05		
D	4.824	4.900	4.976
D1	1.605	1.705	1.805
D2	0.500	0.600	0.700
D3	4.924	5.000	5.076
E	5.924	6.000	6.076
E1	3.375	3.475	3.575
E2	5.674	5.750	5.826
b	0.350	0.400	0.450
e	1.270 TYP.		
L	0.534	0.610	0.686
L1	0.424	0.500	0.576
L2	1.800 REF.		
k	1.190	1.290	1.390
H	0.549	0.625	0.701
θ	8°	10°	12°
ϕ	1.100	1.200	1.300
d			0.100



Symbol	Millimeters		
	MIN.	NOM.	MAX.
A	0.90	1.05	1.20
b	0.35	0.40	0.50
C	0.20	0.25	0.35
D	4.90	5.05	5.20
D1/D2	1.51	1.61	1.71
d	0.50	0.60	0.70
E	6.00	6.15	6.30
E1	5.60	5.75	5.90
E2	3.47	3.57	3.67
e	1.27 BSC.		
H	0.48	0.58	0.68
K	1.17	1.27	1.37
L	0.64	0.74	0.84
L1/L2	0.20 REF.		
θ	8°	10°	12°
M	0.08 REF.		
N	0	-	0.15
O	0.25 REF.		
P	1.28 REF.		

PDFN5*6

Marking Instructions:

Model1:

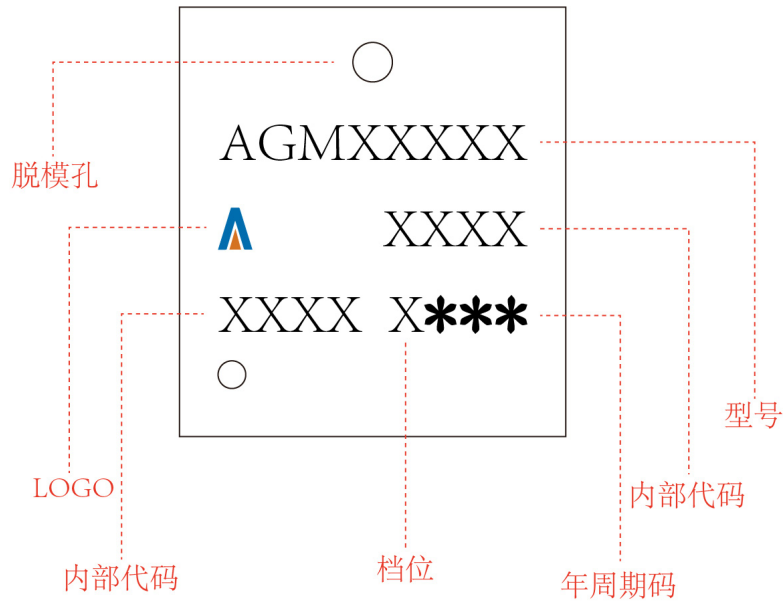

Model2:

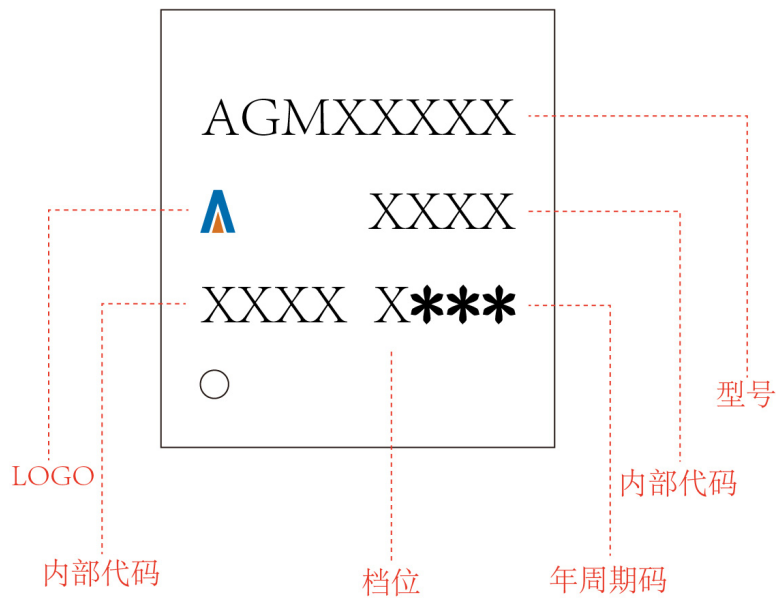

Disclaimer:

The information provided in this document is believed to be accurate and reliable. However, Shenzhen Core Control Source Electronics Technology Co., Ltd. does not assume any responsibility for the following consequences. Do not consider the use of such information or use beyond its scope.

The information mentioned in this document may be changed at any time without notice.

The products and information provided in this document do not infringe patents. Shenzhen Core Control Source Electronics Technology Co., Ltd. assumes no responsibility for any infringement of any other rights of third parties. The result of using such products and information.

This document is the fifth version issued on April 10th, 2024. This document replaces all previously provided information.

 It is a registered trademark of Shenzhen Core Control Source Electronics Technology Co., Ltd.

Copyright © 2017 Shenzhen Core Control Source Electronics Technology Co., Ltd. all rights reserved.