

# ESP32-32E

—2.4GHz Wi-Fi and BLE4.2 Coexistence Module

Version: 1.0

Date: July.20, 2022

## Product Specification

### Features

#### General

- Chip: ESP32-D0WD-V3
- Module Size: 18mm x 25.5mm x 3mm
- Dual-Core 240MHz MCU
- 4MByte embedded flash(default)
- 448KB ROM
- 520KB SRAM+16KB RTC SRAM

#### Wi-Fi Features

- IEEE 802.11 b/g/n-compliant
- Center frequency range of operating channel: 2412 ~ 2484 MHz
- 1T1R mode with data rate up to 150 Mbps
- TX/RX A-MPDU, TX/RX A-MSDU
- Immediate Block ACK

#### Bluetooth Features

- Bluetooth LE: Bluetooth 4.2
- Speed: 125 Kbps, 500 Kbps, 1 Mbps, 2 Mbps
- Advertising extensions
- Multiple advertisement sets
- Channel selection algorithm #2

#### Peripheral Interfaces

- GPIO \* 32;
- IIC + IIS;
- SDIO;
- TWAI (CAN 2.0);
- SPI;
- EN ;
- MCPWM;

- ADC;
- LED PWM;

#### Working Temperature: -40°C-85°C

### Applications

- Serial transparent transmission;
- Wi-Fi prober;
- Smart power plug/Smart LED light;
- Camera product;
- Sensor networks;
- Over-the-top (OTT) devices;
- Wireless location system beacon;
- Industrial field bus;

### Module Type

Name	Flash	Antenna
ESP32-32E-N4	32M bit	PCB
ESP32-32E-N8	64M bit	PCB
ESP32-32E-N16	128M bit	PCB

### Module Structure

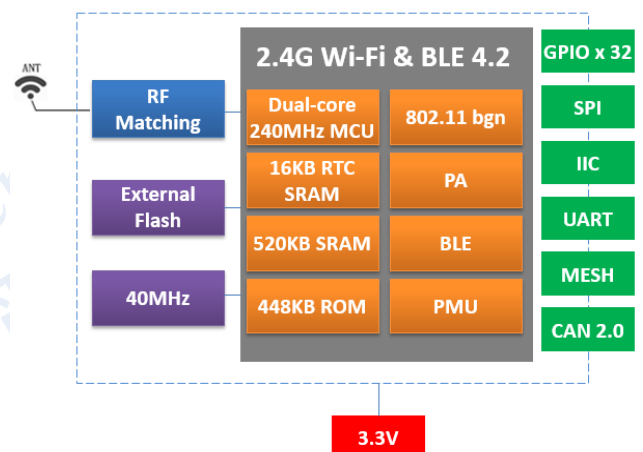

---

## Update Record

Date	Version	Update
2022-07-20	V1.0	First released

---

# Table of Contents

1. Introduction .....	4
2. Interface Definition .....	6
3. Size and Layout .....	9
4. Electronica Characteristics .....	10
5. Power Consumption .....	11
6. Wi-Fi RF Characteristics.....	11
7. Bluetooth LE Radio.....	12
8. Recommended Sold Temperature Curve .....	13
9. Minimum User System.....	13
10. Recommended Layout Design .....	14
11. Peripheral Design Suggestion .....	15
12. Product Handling.....	15
13. Packing Instruction.....	15
Appendix: Module Schematic .....	17

---

# 1. Introduction

ESP32-32E Wi-Fi and BLE coexistence Module is a highly integrated single-chip low power 802.11bgn Wireless LAN (WLAN) network controller. It combines a dual-core 240MHz CPU, WLAN MAC, a 1T1R capable WLAN baseband, RF, and Bluetooth in a single chip. It also provides a bunch of configurable GPIO, which are configured as digital peripherals for different applications and control usage.

ESP32-32E module use ESP32-D0WD-V3 as Wi-Fi and BLE coexistence SOC chip.

ESP32-32E module integrates internal memories for complete Wi-Fi protocol functions. The embedded memory configuration also provides convenient application developments.

ESP32-32E module supports the standard IEEE802.11 b/g/n/e/i protocol and the complete TCP/IP protocol stack. User can use it to add the Wi-Fi function for the installed devices, and also can be viewed as an independent network controller.

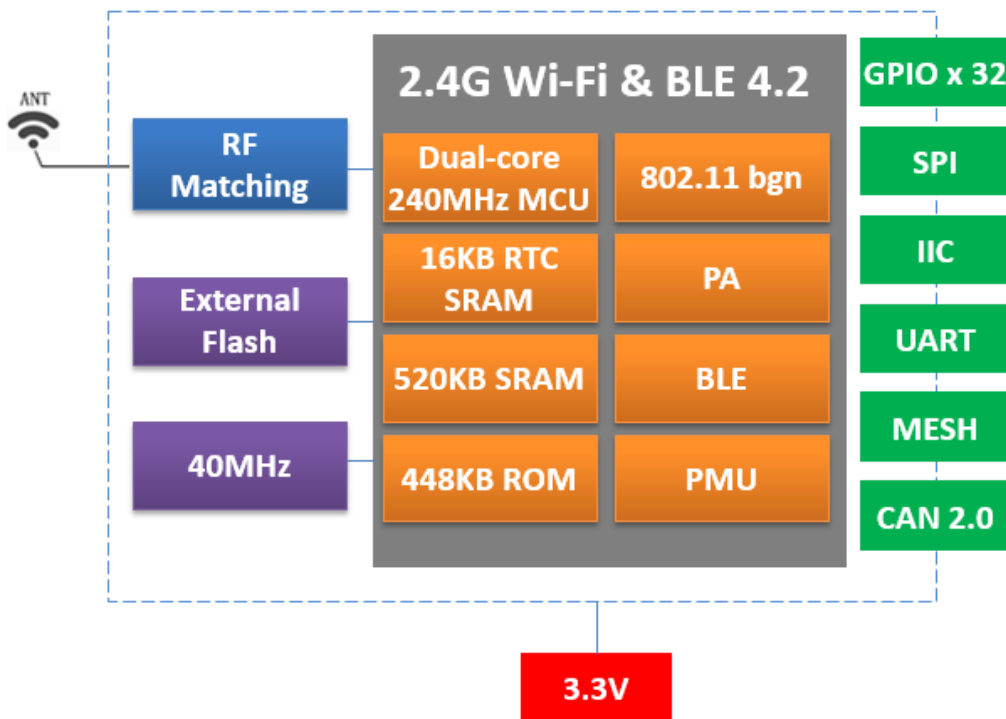

Fig.1.1 ESP32-32E Module Structure

Technical parameters for ESP32-32E are listed as follows.

Table.1.1 ESP32-32E Parameters

Type	Item	Parameter
Wi-Fi	Frequency	2.4G~2.5G (2412M~2484M)
	Transmit power	802.11b: +20 dBm
		802.11g: +16 dBm
		802.11n: +13 dBm
	Receiver sensitivity	802.11b: -98 dBm (11Mbps)
		802.11g: -75 dBm (54Mbps)
		802.11n: -73 dBm (MCS7, HT20)
		802.11n: -70 dBm (MCS7, HT40)
	EVM	-26dB @802.11b,11Mbps @20dBm
		-28dB @802.11g,54Mbps @15dBm
-30dB @802.11n,HT20,MCS7 @13dBm		
-30dB @802.11n,HT40,MCS7 @13dBm		
Antenna	PCB antenna	
BLE	RF power control range	-12~9dBm
Hardware	CPU	Xtensa dual-core 240MHz
	Interface	/UART/SDIO/SPI/I2C/GPIO
	Working voltage	3.0V ~ 3.6V
	Working temperature	-40°C ~ 85°C
	Environment temperature	-40°C ~ 105°C
	Shape	18mm x 25.5mm x 3mm
Software	Wi-Fi working mode	STA, Soft-AP and sniffer modes
	Security mode	WPS / WEP / WPA / WPA2 / WPA3
	Update firmware	UART Download
	Software develop	SDK
	Network protocol	IPv4, TCP/UDP/HTTP/FTP/MQTT

## 2. Interface Definition

ESP32-32E Wi-Fi & BLE module interface definition is shown as below.

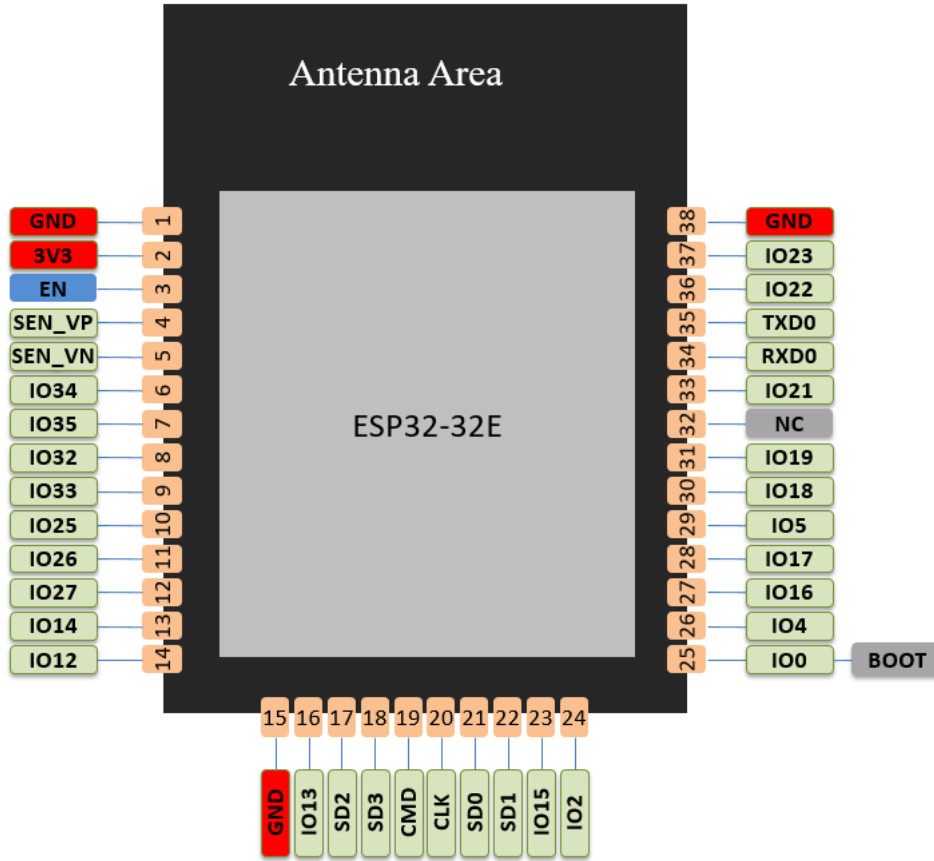

Fig.2.1 ESP32-32E Pins Definition

Working modes and pins function is shown in Table 2.1.

Table.2.1 Working Mode

Mode	IO0 Voltage Level
UART Download Mode	LOW
Flash Boot Mode	HIGH (Default)

Table.2.2 Pins Function Definition

Num.	Pin Name	Type	Function
1	GND	P	Ground
2	3V3	P	Power supply
3	EN	I	Chip enable; Internal Pull-up. HIGH: enable the chip

4	SEN_VP	I	GPIO36, ADC1_CH0, RTC_GPIO0
5	SEN_VN	I	GPIO39, ADC1_CH3, RTC_GPIO3
6	IO34	I	GPIO34, ADC1_CH6, RTC_GPIO4
7	IO35	I	GPIO35, ADC1_CH7, RTC_GPIO5
8	IO32	I/O	GPIO32, XTAL_32K_P (32.768 kHz crystal oscillator input), ADC1_CH4, TOUCH9, RTC_GPIO9
9	IO33	I/O	GPIO33, XTAL_32K_N (32.768 kHz crystal oscillator output), ADC1_CH5, TOUCH8, RTC_GPIO8
10	IO25	I/O	GPIO25, DAC_1, ADC2_CH8, RTC_GPIO6, EMAC_RXD0
11	IO26	I/O	GPIO26, DAC_2, ADC2_CH9, RTC_GPIO7, EMAC_RXD1
12	IO27	I/O	GPIO27, ADC2_CH7, TOUCH7, RTC_GPIO17, EMAC_RX_DV
13	IO14	I/O	GPIO14, ADC2_CH6, TOUCH6, RTC_GPIO16, MTMS, HSPICK, HS2_CLK, SD_CLK, EMAC_TXD2
14	IO12	I/O	GPIO12, ADC2_CH5, TOUCH5, RTC_GPIO15, MTDI, HSPIQ, HS2_DATA2, SD_DATA2, EMAC_TXD3
15	GND	P	Ground
16	IO13	I/O	GPIO13, ADC2_CH4, TOUCH4, RTC_GPIO14, MTCK, HSPID, HS2_DATA3, SD_DATA3, EMAC_RX_ER
17	SD2	I/O	GPIO9, SD_DATA2, SPIHD, HS1_DATA2, U1RXD
18	SD3	I/O	GPIO10, SD_DATA3, SPIWP, HS1_DATA3, U1TXD
19	CMD	I/O	GPIO11, SD_CMD, SPICS0, HS1_CMD, U1RTS
20	CLK	I/O	GPIO6, SD_CLK, SPICK, HS1_CLK, U1CTS
21	SD0	I/O	GPIO7, SD_DATA0, SPIQ, HS1_DATA0, U2RTS
22	SD1	I/O	GPIO8, SD_DATA1, SPID, HS1_DATA1, U2CTS
23	IO15	I/O	GPIO15, ADC2_CH3, TOUCH3, MTDO, HSPICS0, RTC_GPIO13, HS2_CMD, SD_CMD, EMAC_RXD3
24	IO2	I/O	GPIO2, ADC2_CH2, TOUCH2, RTC_GPIO12, HSPIWP, HS2_DATA0, SD_DATA0
25	IO0	I/O	GPIO0, ADC2_CH1, TOUCH1, RTC_GPIO11, CLK_OUT1, EMAC_TX_CLK
26	IO4	I/O	GPIO4, ADC2_CH0, TOUCH0, RTC_GPIO10, HSPIHD, HS2_DATA1, SD_DATA1, EMAC_TX_ER
27	IO16	I/O	GPIO16, HS1_DATA4, U2RXD, EMAC_CLK_OUT
28	IO17	I/O	GPIO17, HS1_DATA5, U2TXD, EMAC_CLK_OUT_180

29	IO5	I/O	GPIO5, VSPICS0, HS1_DATA6, EMAC_RX_CLK
30	IO18	I/O	GPIO18, VSPICLK, HS1_DATA7
31	IO19	I/O	GPIO19, VSPIQ, U0CTS, EMAC_TXD0
32	NC	-	-
33	IO21	I/O	GPIO21, VSPIHD, EMAC_TX_EN
34	RXD0	I/O	GPIO3, U0RXD, CLK_OUT2
35	TXD0	I/O	GPIO1, U0TXD, CLK_OUT3, EMAC_RXD2
36	IO22	I/O	GPIO22, VSPIWP, U0RTS, EMAC_TXD1
37	IO23	I/O	GPIO23, VSPID, HS1_STROBE
38	GND	P	Ground

### 3. Size and Layout

Size for ESP32-32E can be shown as follows.



Fig.3.1 Shape for ESP32-32E

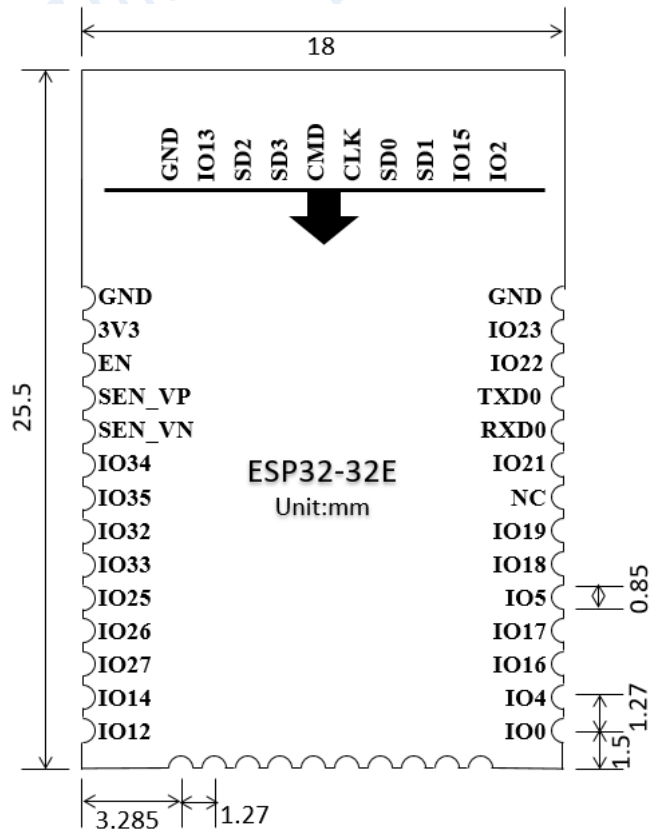

(a) Vertical View



Electrostatic Release Quantity (Machine model)	TAMB=25°C	-	-	0.5	KV
--	-----------	---	---	-----	----

## 5. Power Consumption

Table.5.1 Power Consumption

Parameters	Min	Classical	Max	Unit
RX 11b /g/n, HT20	-	-	95	mA
RX 11n, HT40	-	-	97	mA
TX 11b, 1Mbps @19dBm	-	-	240	mA
TX 11g, 54Mbps @16dBm	-	-	190	mA
TX 11n, HT20, MCS7, @13dBm	-	-	180	mA
TX 11n, HT40, MCS7, @13dBm	-	-	180	mA
Modem-sleep, CPU is powered on @240MHz	-	68	-	mA
Light-sleep	-	0.8	-	mA
Deep-sleep, RTC timer + RTC memory	-	10	-	uA
Power off, CHIP_PU is set to low level	-	1	0	uA

The peak current consumption of ESP32-32E exceed 500mA when the module start work (RF calibration work consumes maximum current). Therefore, the recommended power supply is no less than 500mA.

Note:

1. Active Mode: CPU and RF are all turned on.
2. Modem-sleep Mode: CPU is turned on. RF and baseband are turned off, but the communication is still connected.
3. Light-sleep Mode: CPU is turned off. RTC/external interrupt/MAC can wake up the chip. The communication is still connected.
4. Deep-sleep Mode: Only RTC is turned on.

## 6. Wi-Fi RF Characteristics

The data in the following table is gotten when voltage is 3.3V in the indoor temperature environment.

Table.6.1 Wi-Fi TX Characteristics

Parameters	Min	Classical	Max	Unit
Input frequency	2412	-	2484	MHz
802.11b	-	20.0	-	dBm
802.11n,MCS7	-	13	-	dBm

Table.6.2 Wi-Fi RX Sensitivity

Parameters	Min	Classical	Max	Unit
802.11b,1Mbps	-	-98	-	dBm
802.11b,11Mbps	-	-89	-	dBm
802.11g,6Mbps	-	-92	-	dBm
802.11g,54Mbps	-	-74	-	dBm
802.11n,HT20,MCS0	-	-91	-	dBm
802.11n,HT20,MCS7	-	-71	-	dBm
802.11n,HT40,MCS0	-	-89	-	dBm
802.11n,HT40,MCS7	-	-69	-	dBm

Table.6.3 Wi-Fi RX Characteristics

Parameters	Min	Classical	Max	Unit
ADJ Channel Rejection @ 11g, 6Mbps	-	31	-	dB
ADJ Channel Rejection @ 11g, 54Mbps	-	14	-	dB
ADJ Channel Rejection @ 11n,HT20,MCS0	-	31	-	dB
ADJ Channel Rejection @ 11n,HT20,MCS7	-	13	-	dB

## 7. Bluetooth LE Radio

Table.7.1 TX Transmitter General Characteristics

Parameters	Min	Classical	Max	Unit
RF power control range	-12	3	9	dBm
ADJ channel Transmit Power @F-F0±2MHz	-	-52	-	dBm
ADJ channel Transmit Power @F-F0±3MHz	-	-58	-	dBm
ADJ channel Transmit Power @F-F0±>3MHz	-	-60	-	kHz
$\Delta f_{1avg}$	-	-	265	kHz

$\Delta f_{2max}$	247	-	-	kHz
ICFT	-	-10	-	kHz

Table.7.2 RX Transmitter General Characteristics

Parameters		Min	Classical	Max	Unit
B L E	Sensitivity @30.8% PER	-	-96.5	-	dBm
	Maximum received signal @30.8% PER	0	-	-	dBm
	Co-channel C/I	-	10	-	dB

### 8. Recommended Solder Temperature Curve

- (1) Reflow Times  $\leq$  2 times (Max.)
- (2) Max Rising Slope: 3°C/sec
- (3) Max Falling Slope: -3°C/sec
- (4) Over 217°C Time: 60~120sec
- (5) Peak Temp: 240°C~250°C

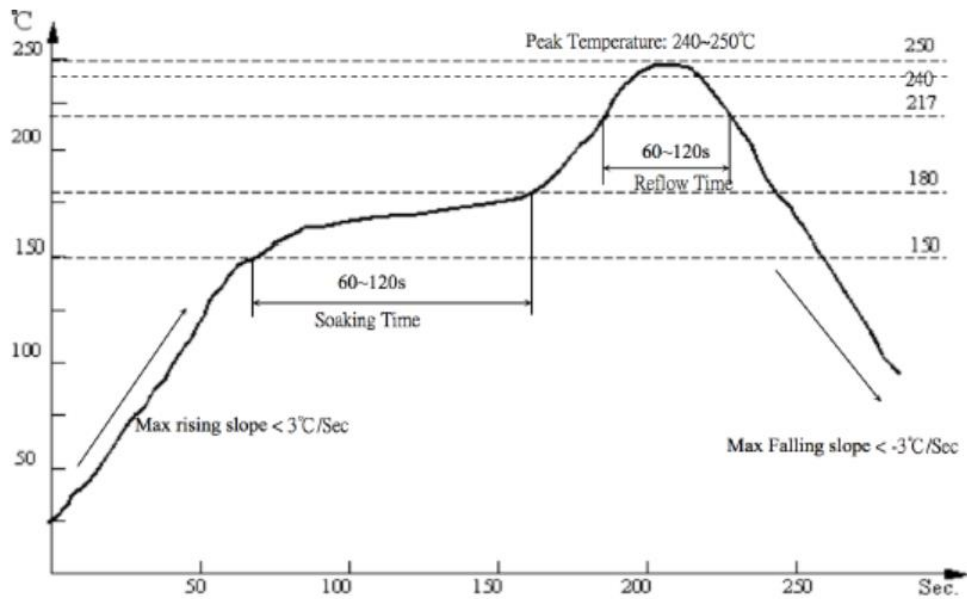

Fig.8.1 Recommended Reflow Profile

### 9. Minimum User System

This module can work just at 3.3V voltage condition:

Note:

- (1) The working voltage for module is DC 3.3V;
- (2) The max current from IO of this module is 40mA;

(3) Wi-Fi module is at download mode: IO0 is LOW level, then module reset to power;

(4) Wi-Fi module is connected to RXD of the other MCU, and TXD is connected to RXD of the other MCU.

## 10. Recommended Layout Design

ESP32-32E module can be sold on PCB board directly. For the high RF performance for the device, please notice the placement of the module. There are three ways to use the module for Wi-Fi Module with PCB antenna.

Solution 1: optical solution. The Wi-Fi module is placed on the side of the board, and the antennas are all exposed, and there is no metal material around the antenna, including wires, metal casings, weight plates, and the like.

Solution 2: sub-optical solution. The Wi-Fi module is placed on the side of the board, and the antenna below is hollowed out. There is a gap of not less than 5 mm reserved with the PCB, and there is no metal material around the antenna, including wires, metal casings, weight plates, and the like.

Solution 3: The Wi-Fi module is placed on the side of the board, and the PCB area under the antenna is empty, and copper cannot be laid.

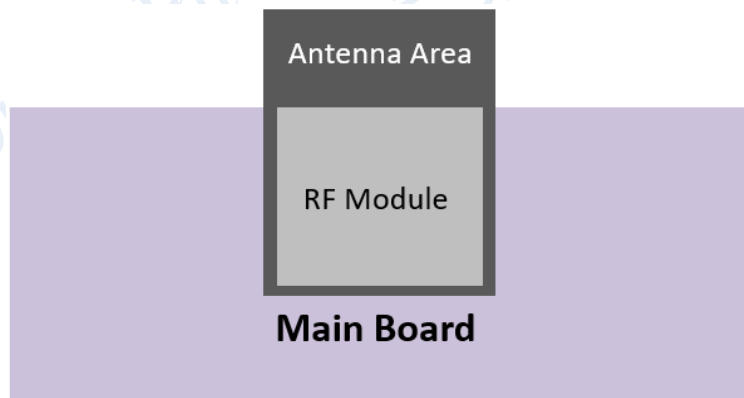

Fig.10.1 Solution 1

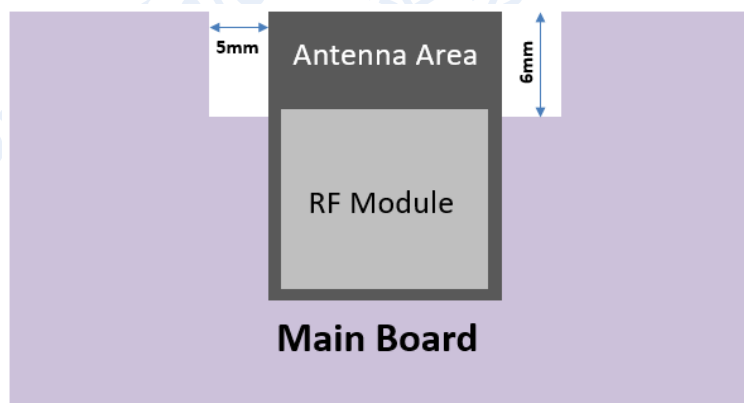

Fig.10.2 Solution 2

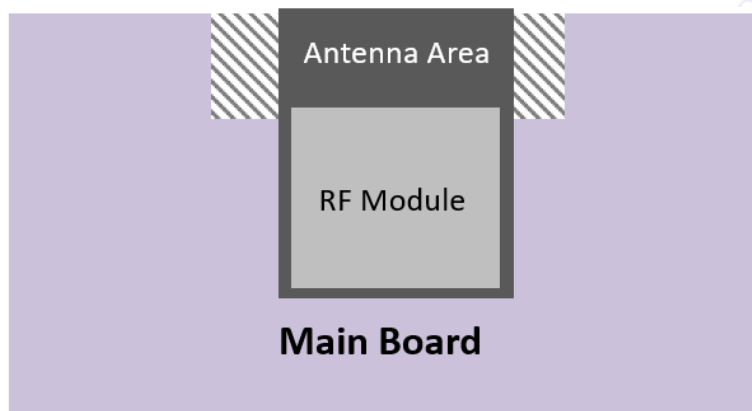

Fig.10.3 Solution 3

## 11. Peripheral Design Suggestion

Wi-Fi module is already integrated into high-speed GPIO and Peripheral interface, which may be generated the switch noise. If there is a high request for the power consumption and EMI characteristics, it is suggested to connect a serial 10~100 ohm resistance, which can suppress overshoot when switching power supply, and can smooth signal. At the same time, it also can prevent electrostatic discharge (ESD).

## 12. Product Handling

### 12.1 Storage Conditions

The products sealed in moisture barrier bags (MBB) should be stored in a non-condensing atmospheric environment of  $< 40\text{ }^{\circ}\text{C}$  and 90%RH. The module is rated at the moisture sensitivity level (MSL) of 3. After unpacking, the module must be soldered within 168 hours with the factory conditions  $25\pm 5\text{ }^{\circ}\text{C}$  and 60%RH. If the above conditions are not met, the module needs to be baked.

### 12.2 Electrostatic Discharge (ESD)

- Human body model (HBM):  $\pm 2000\text{ V}$
- Charged-device model (CDM):  $\pm 500\text{ V}$

## 13. Packing Instruction

The product is packed in a tray, as shown in the following figure.

The size of the single box is: 340 x 360 x 60mm, and 650 pieces module is in the box. And the outer box size is 355 x 375 x 325mm, including 5 single box which include 3250 pieces module.



Fig.13.1 Module Package

# Appendix: Module Schematic

