

Features

- 37Watts peak pulse power (tp = 8/20us)
- Snap-Back technology
- Low clamping voltage
- Low leakage current
- Ultra low capacitance (0.25pF typical)
- ESD Protection for high-speed data lines
- IEC 61000-4-2 ±10kV contact ±12kV air
- IEC 61000-4-4 (EFT) 40A (5/50ns)
- IEC 61000-4-5 (Lightning) 5A (8/20µs)
- RoHS compliant
- “-C” suffix is for Automotive applications, AEC-Q101 qualified

Package

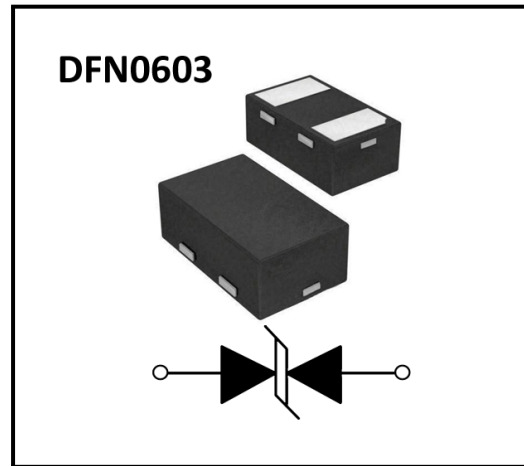

Applications

- USB 3.0, USB 2.0, MHL
- HDMI 2.0, Display Port 1.3, eSATA
- Unified Display Interface (UDI)
- Digital Visual Interface (DVI)
- 1G/2.5G/5G/10G Ethernet

Marking

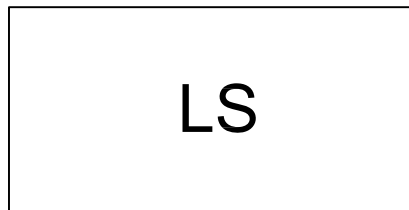

Ordering information

Device	Package	Carrier	Quantity	HSF Status
BSDFN1C031RA	DFN0603	Tape & Reel (7")	10000pcs / Ree	Rohs Compliant
BSDFN1C031RA-C	DFN0603	Tape & Reel (7")	10000pcs / Ree	Rohs Compliant



Electrical Parameters (T_A = 25°C unless otherwise noted)

Symbol	Parameter
I _{PP}	Maximum Reverse Peak Pulse Current
V _C	Clamping Voltage @ I _{PP}
V _{RWM}	Peak Reverse Working Voltage
I _R	Maximum Reverse Leakage Current @ V _{RWM}
V _T	Trigger voltage
I _T	Test Current
V _H	Holding voltage
I _H	Holding Current

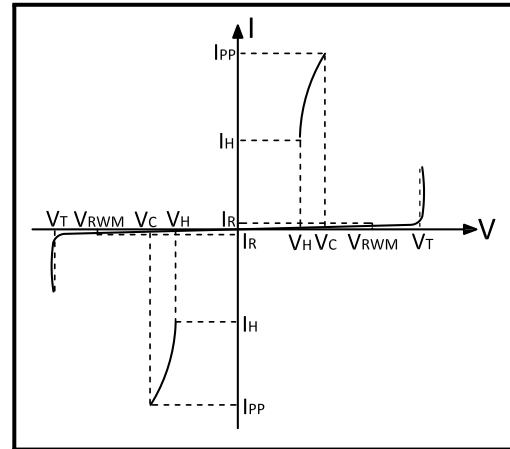

Note: 8/20us pulse Waveform.

Absolute Maximum Rating

Rating	Symler	Value	Units
Peak Pulse Power (t _p = 8/20μs)	P _{PP}	37	Watts
Peak Pulse Current (t _p = 8/20μs)	I _{PP}	5	A
ESD per IEC 61000-4-2 (Air)	V _{ESD}	±12	KV
ESD per IEC 61000-4-2 (Contact)		±10	
Junction Temperature	T _J	-55 to + 150	°C
Storage temperature range	T _{stg}	-55 to + 150	°C

Electrical Characteristics(T_A=25°C, Unless otherwise specified.)

Parameter	Symler	Conditions	Min.	Typ.	Max.	Units
Reverse Stand-Off Voltage	V _{RWM}	–	–	–	3.3	V
Reverse Breakdown Voltage	V _{BR}	I _T =1mA	5.5	6.8	12	V
Trigger voltage	V _T	I _{PP} = 5A, t _p = 8/20us	–	9.0	–	V
Reverse Leakage Current	I _R	V _{RWM} =3.3V	–	0.01	0.1	uA
Peak Pulse Current	I _{PP}	t _p = 8/20us	–	–	5	A
Clamping Voltage	V _C	I _{PP} =5A, t _p = 8/20us	–	6.5	8.0	V
Clamping Voltage(TLP 8A)		IEC 61000-4-2 Level 2 (±4 kV Contact, ±4 kV Air)	–	4.5	–	
Clamping Voltage(TLP 16A)		IEC 61000-4-2 Level 4 (±8 kV Contact, ±8 kV Air)	–	6.0	–	
Dynamic resistance	R _{dyn}	0A ≤ I _R ≤ 30 A; t _p = TLP	–	0.25	–	Ω
Junction Capacitance	C _J	V _R = 0V, f = 1MHZ	–	0.25	0.35	pF





BSDFN1C031RA / BSDFN1C031RA-C

ESD Protection Diode

Typical Characteristics

Figure 1: Peak Pulse Power vs. Pulse Time

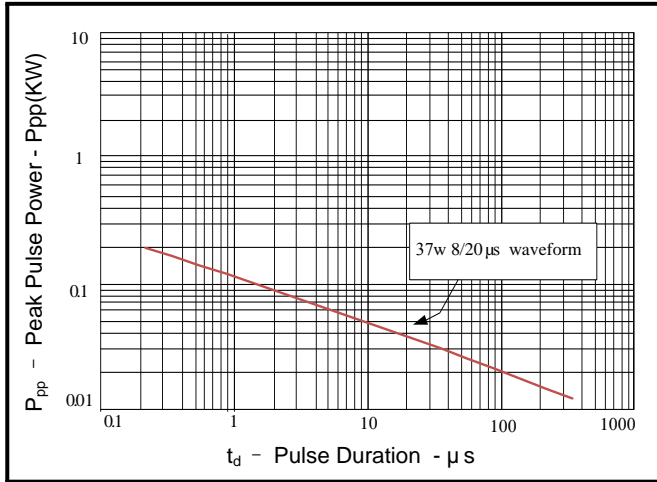

Figure 2: Power Derating Curve

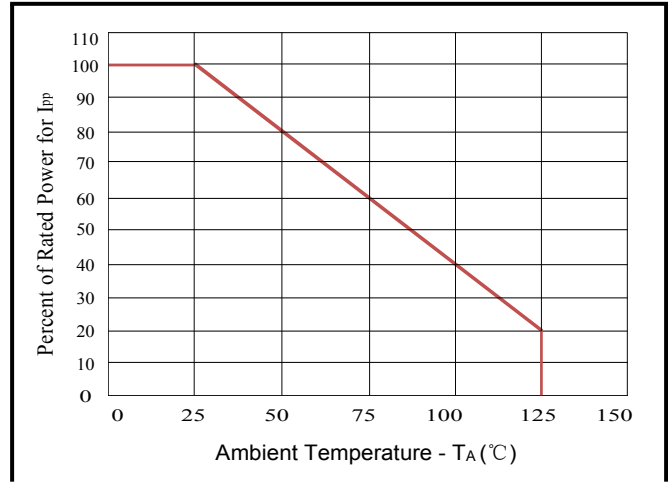

Figure 3: Pulse Waveform

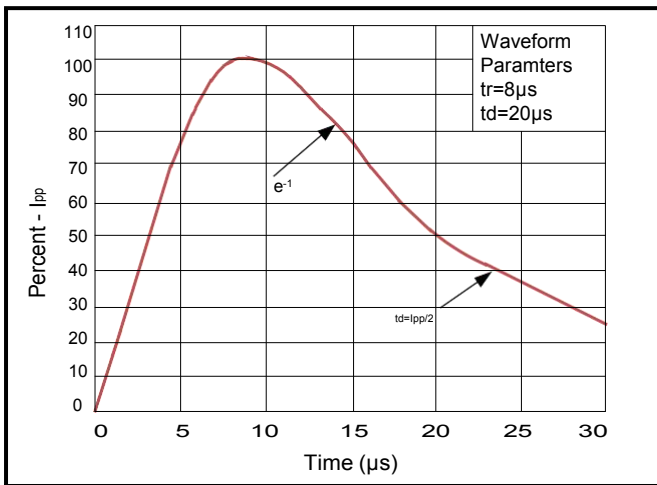
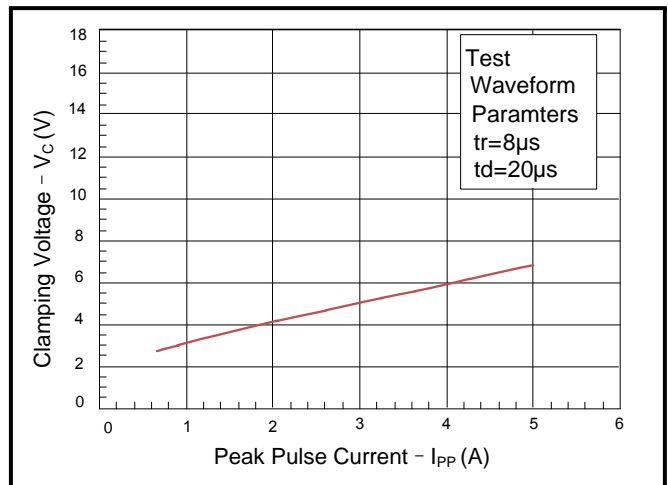
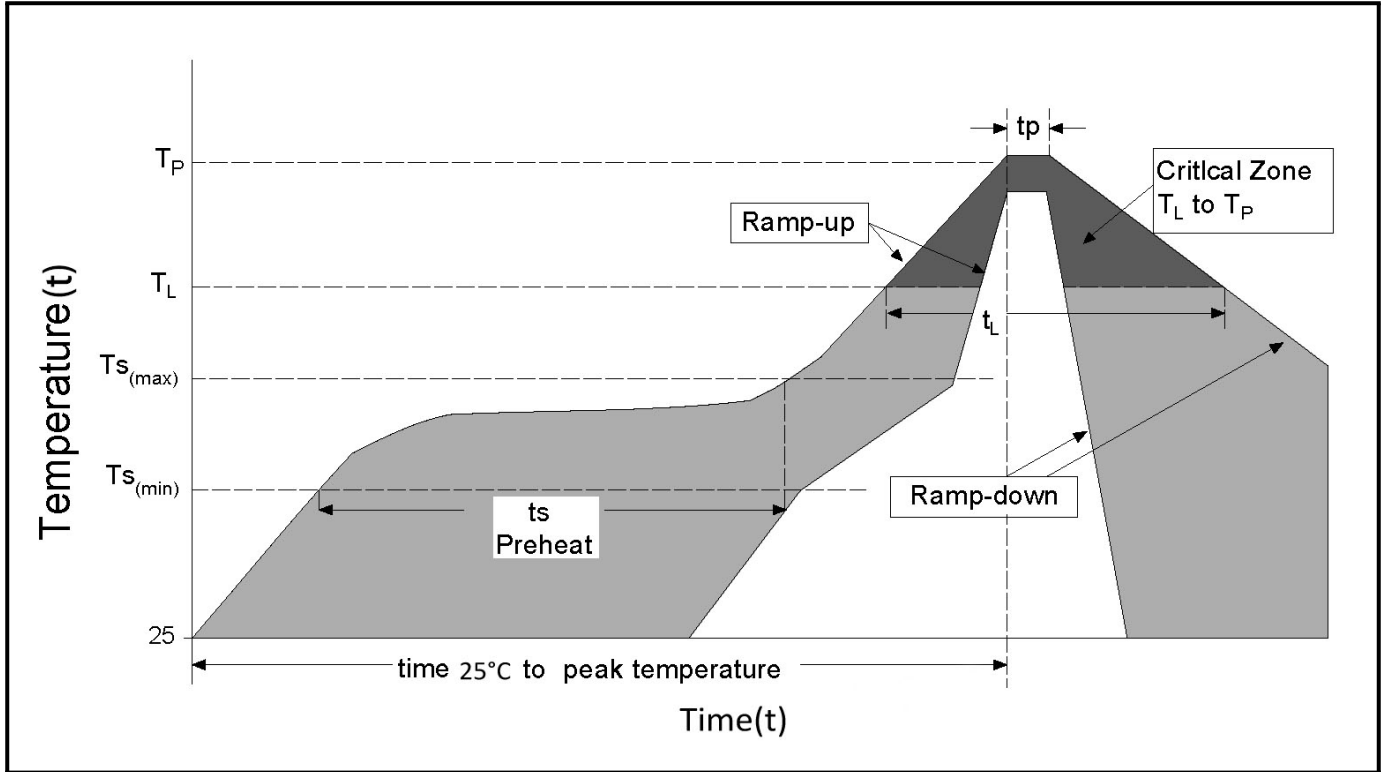

Figure 4: Clamping Voltage vs. I_PP



Soldering Parameters



Reflow Condition		Lead-free assembly
Pre Heat	- Temperature Min ($T_{S(min)}$)	150°C
	- Temperature Max ($T_{S(max)}$)	200°C
	- Time (min to max) (t_s)	60 - 180 secs
Average ramp up rate (Liquidus Temp (T_L) to peak)		3°C/second max
$T_{S(max)}$ to T_L - Ramp-up Rate		3°C/second max
Reflow	- Temperature (T_L) (Liquidus)	217°C
	- Time (t_L)	60 - 150 secs
Peak Temperature (T_P)		260 ^{+0/-5} °C
Time within 5°C of actual peak Temperature (t_p)		20 - 40 secs
Ramp-down Rate		6°C/second max
Time 25°C to peak Temperature (t)		8 minutes Max.
Do not exceed		260°C



Outline Drawing – DFN0603

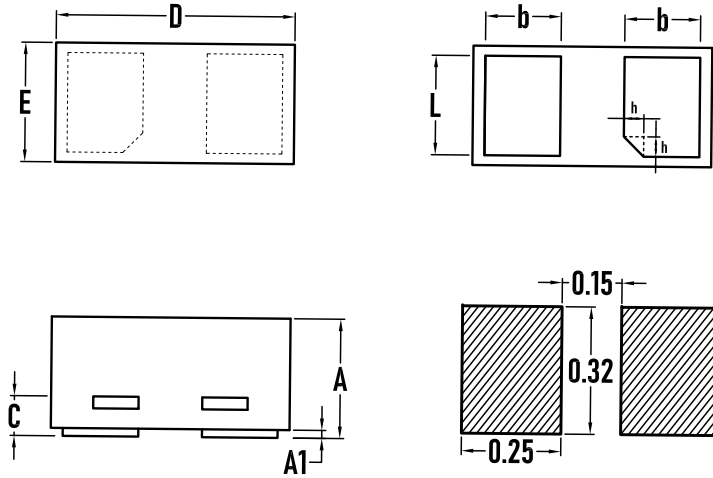

SYMBOL	MILLIMETER		
	MIN.	Typ.	MAX.
A	0.28	0.30	0.32
A1	0.00	0.02	0.05
C	0.05	0.10	0.15
D	0.55	0.60	0.65
E	0.25	0.30	0.35
b	0.14	0.19	0.24
L	0.20	0.25	0.30
h	–	0.05	0.10

Packaging Tape - DFN0603

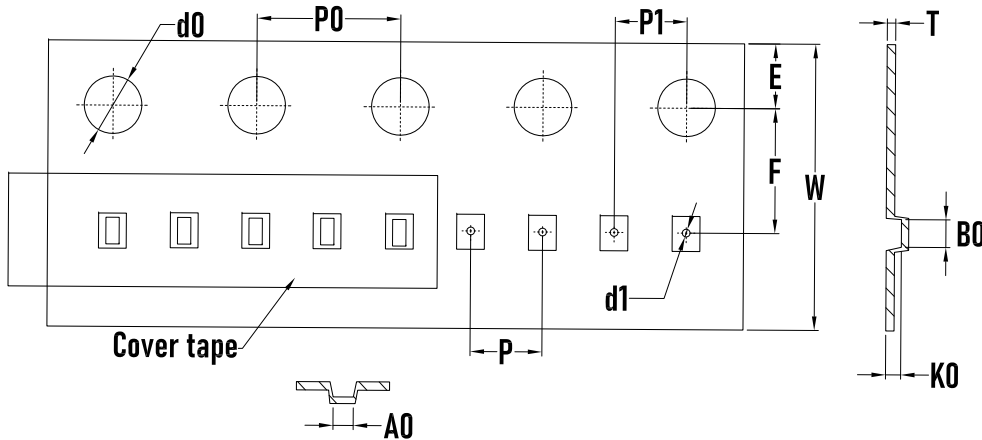

SYMBOL	MILLIMETER
A0	0.39±0.03
B0	0.70±0.03
d0	1.55±0.05
d1	0.20±0.05
E	1.75±0.10
F	3.50±0.04
K0	0.37 ^{+0.03} _{-0.02}
P	2.00±0.10
P0	4.00±0.10
P1	2.00±0.05
W	8.00±0.10
T	0.18±0.03

Packaging Reel

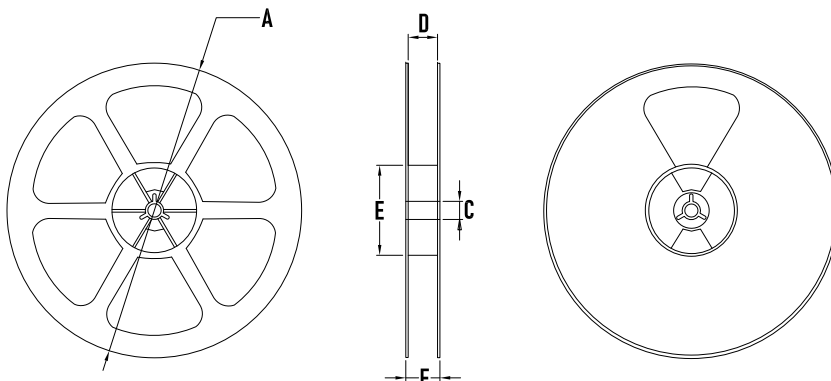

SYMBOL	MILLIMETER
A	178±2
C	13.0 ^{+0.5} _{-0.2}
D	9.5
E	55±5
F	14.4 max.
Quantity	10000PCS

