

### Features

- ▶ The plastic package carries Underwriters Laboratory Flammability Classification 94V-0
- ▶ For surface mounted applications
- ▶ Metal silicon junction, majority carrier conduction
- ▶ Low power loss, high efficiency
- ▶ Built-in strain relief, ideal for automated placement
- ▶ High forward surge current capability
- ▶ High temperature soldering guaranteed: 260°C/10 seconds at terminals
- ▶ Compliant to RoHS 2.0

### Mechanical data

- ▶ **Case:** JEDEC DO-214AC molded plastic body
- ▶ **Terminals:** Solder plated, solderable per MIL-STD-750, Method 2026
- ▶ **Polarity:** Color band denotes cathode end
- ▶ **Mounting Position:** Any

### Package outline

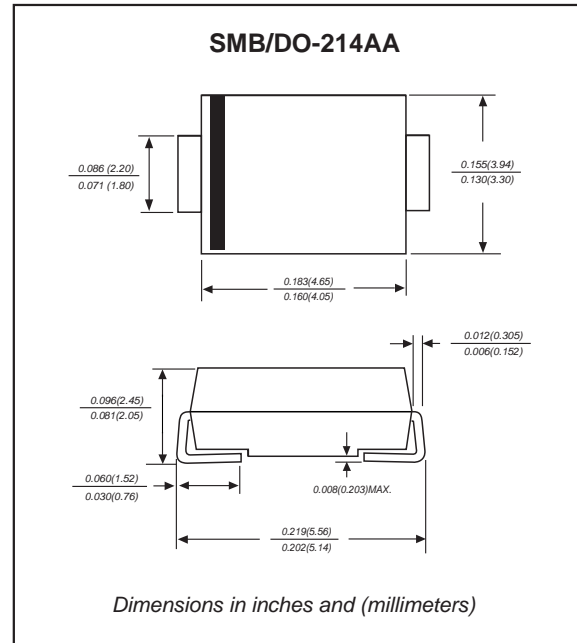

### Maximum ratings and Electrical Characteristics (AT $T_A=25^\circ\text{C}$ unless otherwise noted)



	SYMBOLS	SS52B	SS53B	SS54B	SS55B	SS56B	SS58B	SS510B	SS515B	SS520B	UNITS
Maximum repetitive peak reverse voltage	$V_{RRM}$	20	30	40	50	60	80	100	150	200	V
Maximum RMS voltage	$V_{RMS}$	14	21	28	35	42	56	70	105	140	V
Maximum DC blocking voltage	$V_{DC}$	20	30	40	50	60	80	100	150	200	V
Maximum average forward rectified current at $T_L$ (see fig.1)	$I_{AV}$	5.0									A
Peak forward surge current 8.3ms single half sine-wave superimposed on rated load	$I_{FSM}$	150.0									A
Maximum instantaneous forward voltage at 5.0A	$V_F$	0.55		0.70		0.85		0.95			V
Maximum DC reverse current $T_A=25^\circ\text{C}$ at rated DC blocking voltage $T_A=100^\circ\text{C}$	$I_R$	0.5			10.0		5.0		2.0		mA
Typical junction capacitance (NOTE 1)	$C_J$	500									pF
Typical thermal resistance (NOTE 2)	$R_{\theta JA}$	50									$^\circ\text{C/W}$
Operating junction temperature range	$T_J$	-55 to +150									$^\circ\text{C}$
Storage temperature range	$T_{STG}$	-55 to +150									$^\circ\text{C}$

**Note:**1. Measured at 1MHz and applied reverse voltage of 4.0V D.C.  
2.P.C.B. mounted with 2.0x2.0" (5.0x5.0cm) copper pad areas

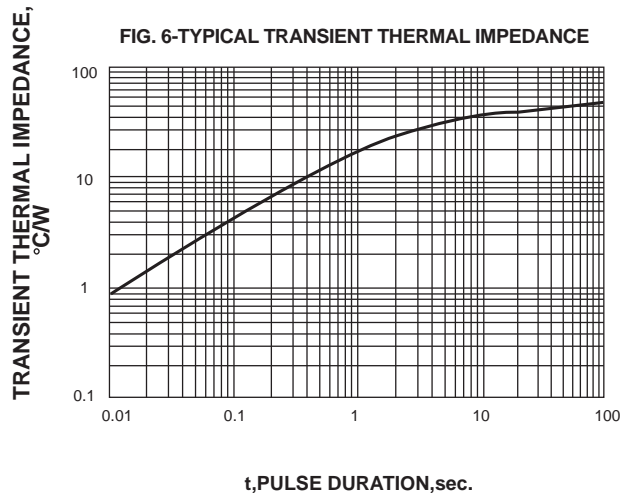
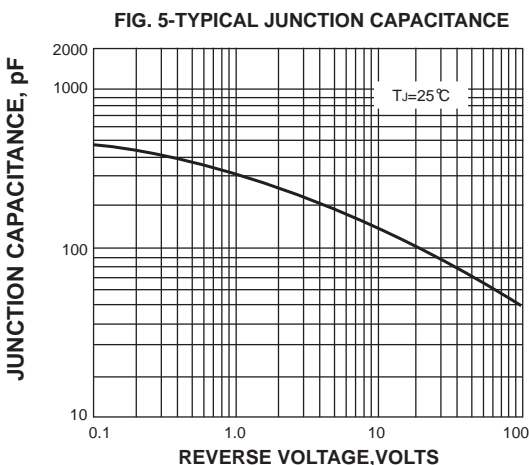
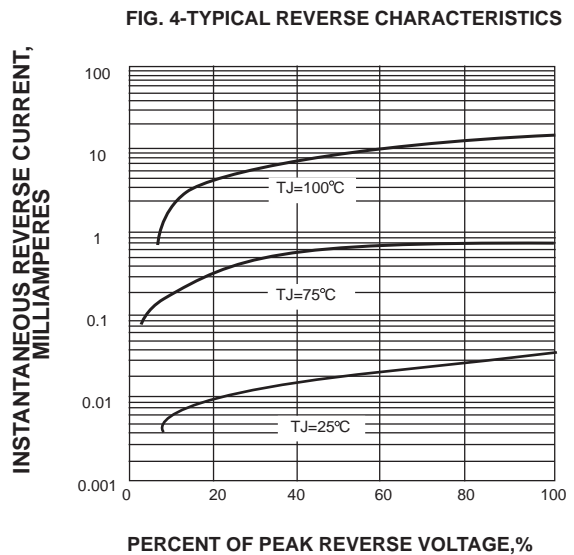
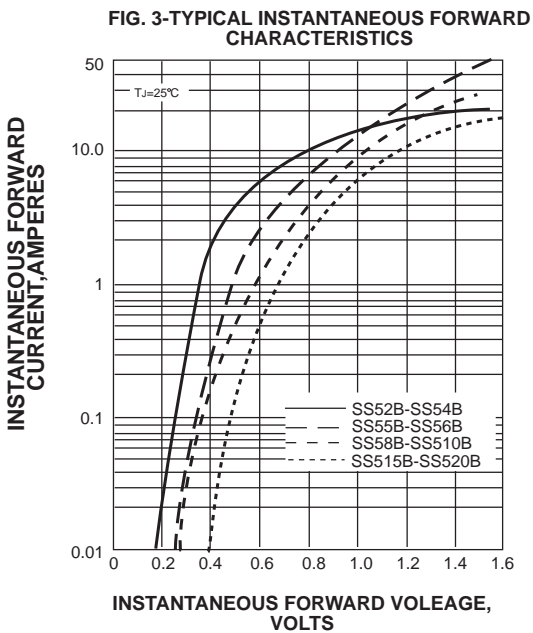
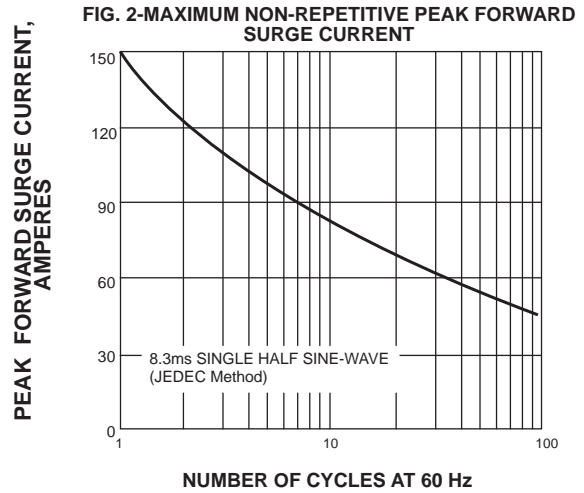
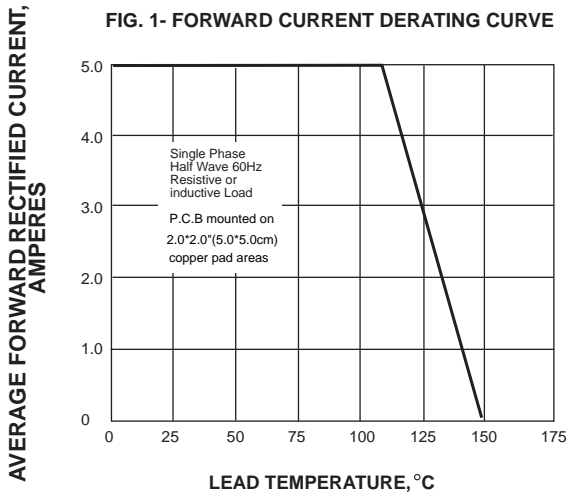
### Rating and characteristic curves



## Pinning information

Pin	Simplified outline	Symbol
Pin1 cathode Pin2 anode		

## Marking

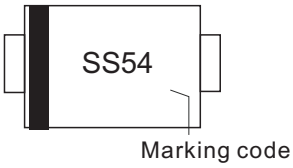
Type number	Marking code	Example
SS52B	SS52	
SS53B	SS53	
SS54B	SS54	
SS55B	SS55	
SS56B	SS56	
SS58B	SS58	
SS510B	SS510	
SS515B	SS515	
SS520B	SS520	

## Suggested solder pad layout

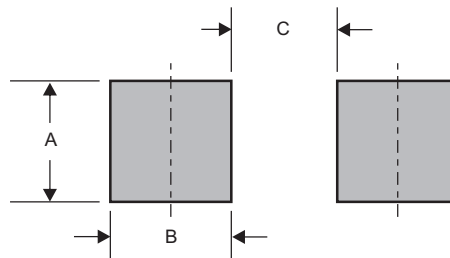

Dimensions in inches and (millimeters)

PACKAGE	A	B	C
SMB	0.078 (2.00)	0.059 (1.50)	0.110 (2.80)

**Suggested thermal profiles for soldering processes**

- 1.Storage environment: Temperature=5°C~40°C Humidity=55%±25%
- 2.Reflow soldering of surface-mount devices

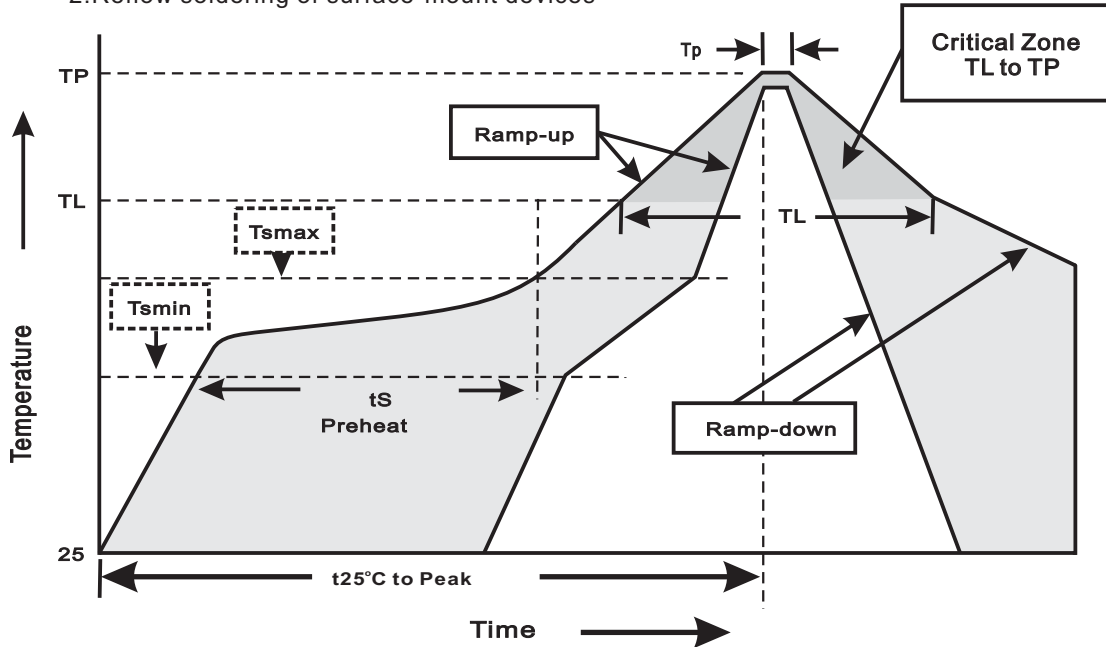

3.Reflow soldering

Profile Feature	Soldering Condition
Average ramp-up rate(T <sub>L</sub> to T <sub>P</sub> )	<3°C/sec
Preheat -Temperature Min(T <sub>smín</sub> ) -Temperature Max(T <sub>smáx</sub> ) -Time(min to max)(t <sub>s</sub> )	150°C 200°C 60~120sec
T <sub>smáx</sub> to T <sub>L</sub> -Ramp-upRate	<3°C/sec
Time maintained above: -Temperature(T <sub>L</sub> ) -Time(t <sub>L</sub> )	217°C 60~260sec
Peak Temperature(T <sub>P</sub> )	255°C-0/+5°C
Time within 5°C of actual Peak Temperature(t <sub>P</sub> )	10~30sec
Ramp-down Rate	<6°C/sec
Time 25°C to Peak Temperature	<6minutes