

# 常州华龙电子有限公司

## SPECIFICATION FOR APPROVAL

### 规格承认书

Customer 客户:	
Customer Part No. 客户型号:	
PART NO. 产品型号:	HDM-4015B423-001
FUNCTION. 产品功能	MICROPHONE
SPEC. NO. 规格书号:	DSM064-2011

Drawn by 制作	Checked by 审核	Approved by 批准	Customer approved 客户承认
Lily 2011-10-05	曹丽萍 2011-10-05	王台平 2011-10-05	

Our products meet the latest RoHS compliance  
 我司生产产品均符合欧盟 RoHS 最新要求



ISO 9001 Certified

总公司地址：台北市北投区中央南路 2 段 33 号 3 楼  
 大陆分公司地址：中国江苏省常州市新北区电子园新四路 36 号  
 一厂：江苏省常州市新北区电子园新四路 36 号  
 二厂：江苏省常州市溧阳市社渚经济开发区社农路 1 号  
 电话：+86-519-85106698 85111259 85110078  
 传真：+86-519-85101081 85107616  
 网址：www.dshualong.com

**Approval 承認內容:**

1. History change record 变更记录
2. Characteristics 技术参数
3. Typical Frequency Response Curve 频率曲线
4. Dimension 外观尺寸
5. Reliability Test 可靠性测试
6. Packing 包裝

2. History change record

Change Items	Date	Note	Drawn by	Checked by
	2011-10-05	First Issue	Lily	王台平 2011-10-05

## 2. Characteristics

Standard Conditions:

Generally Temperature 15~35°C

01	Electret Type	Back type
02	Sensitivity	-42 ± 3dB (0dB=1V/Pa,1KHz)
03	Output Impedance (Max)	2.2K Ω
04	Directivity	Omnidirectional
05	Frequency Range	70-20,000Hz
06	Max.Operation Voltage	10V
07	Standard Operation Voitage	2.0V
08	Current Consumption	Max.0.5mA
09	Sensitivity Reduction	Within -3dB 0dB=1V/Pa,1KHz Vs=2.0 to 1.5V
10	S/N Ratio	≥ 58dB
11	Operating Temperature	-25~+70°C
12	Storage Temperature	-40~+70°C

Generally Humidity 45~85%

Generally Atmospheric Pressure 860~1060hpa

Basic Test Conditions:

Temperature 20±2°C

Humidity 60~70%

Generally Atmospheric Pressure 860~1060hpa

Electrical Characteristics Test Condition:

Vs=2.0V RL=2.2KΩ Te=20°C R. H.=60%

### Standard Test Circuit

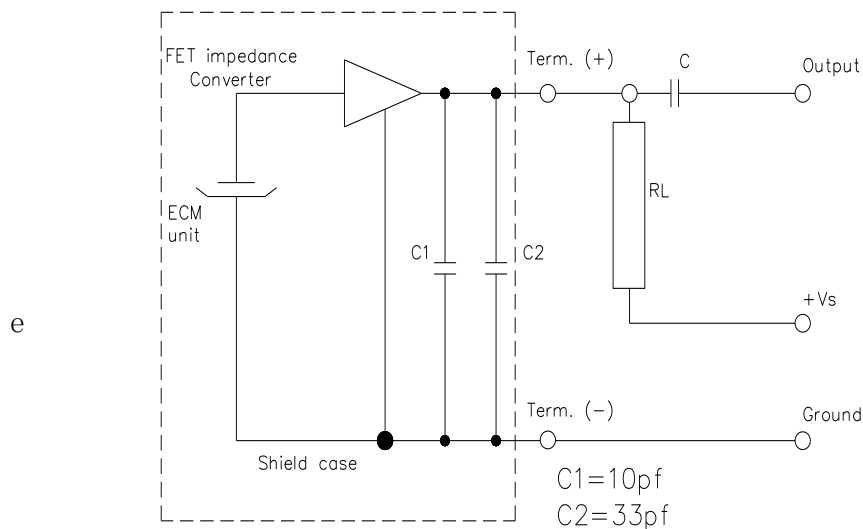

### Standard Test Condition Of Microphone

#### MEASUREMENT OF SENSITIVITY

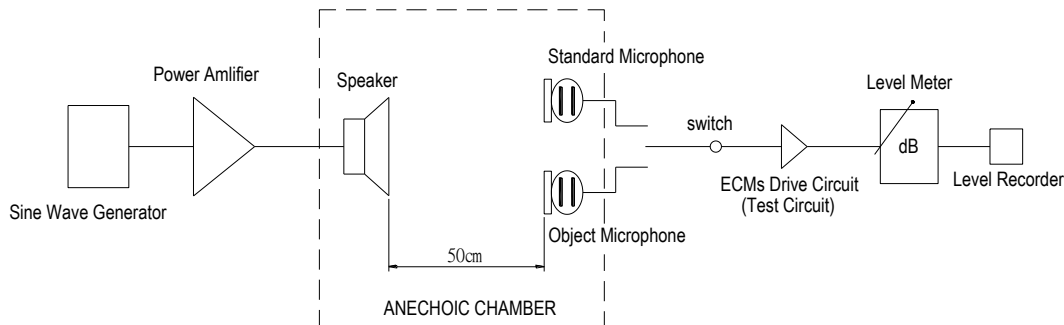

### 3. Frequency Response Tolerance Window

**X : 1000 Hz**      **Y : -43.9 dBV/Pa**  
                          **Y : -41.7 dBm/Pa**  
                          **D : 0.0 dB**

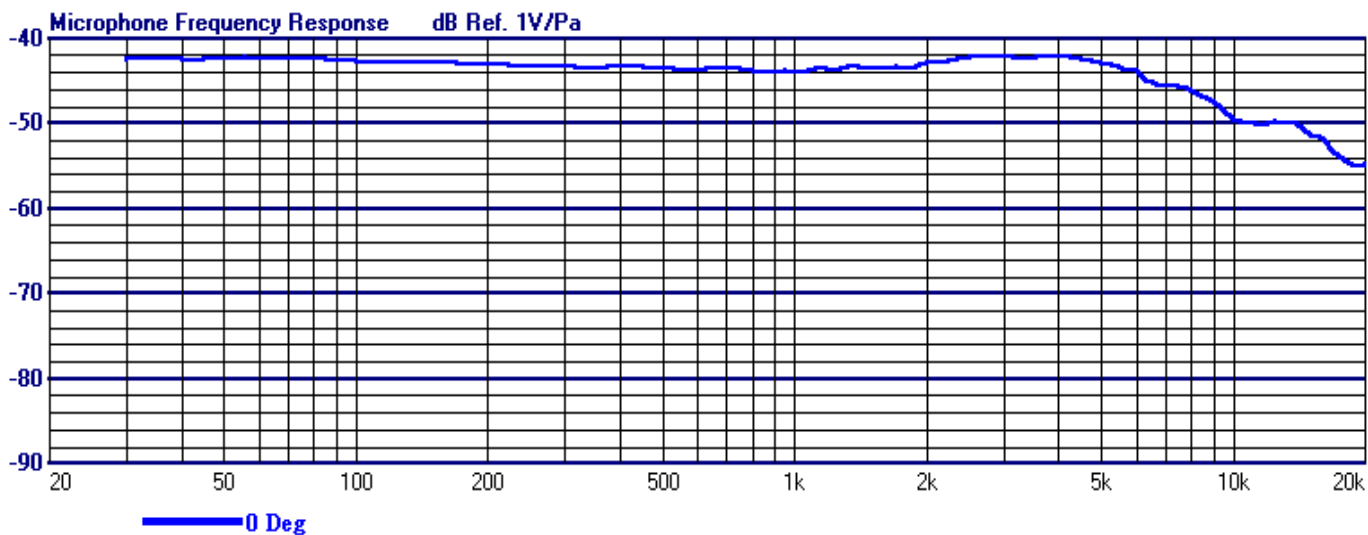

4. Dimension

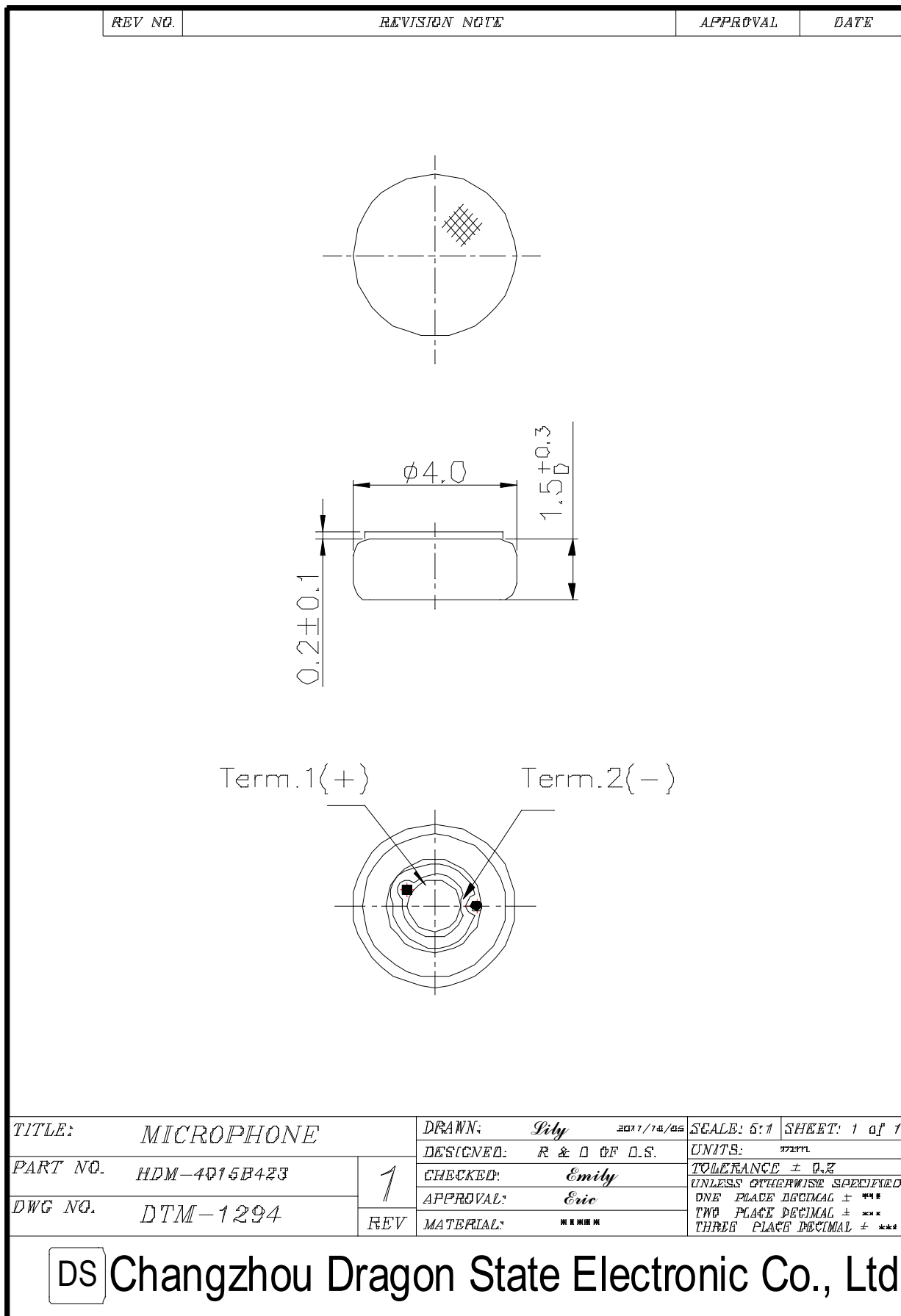

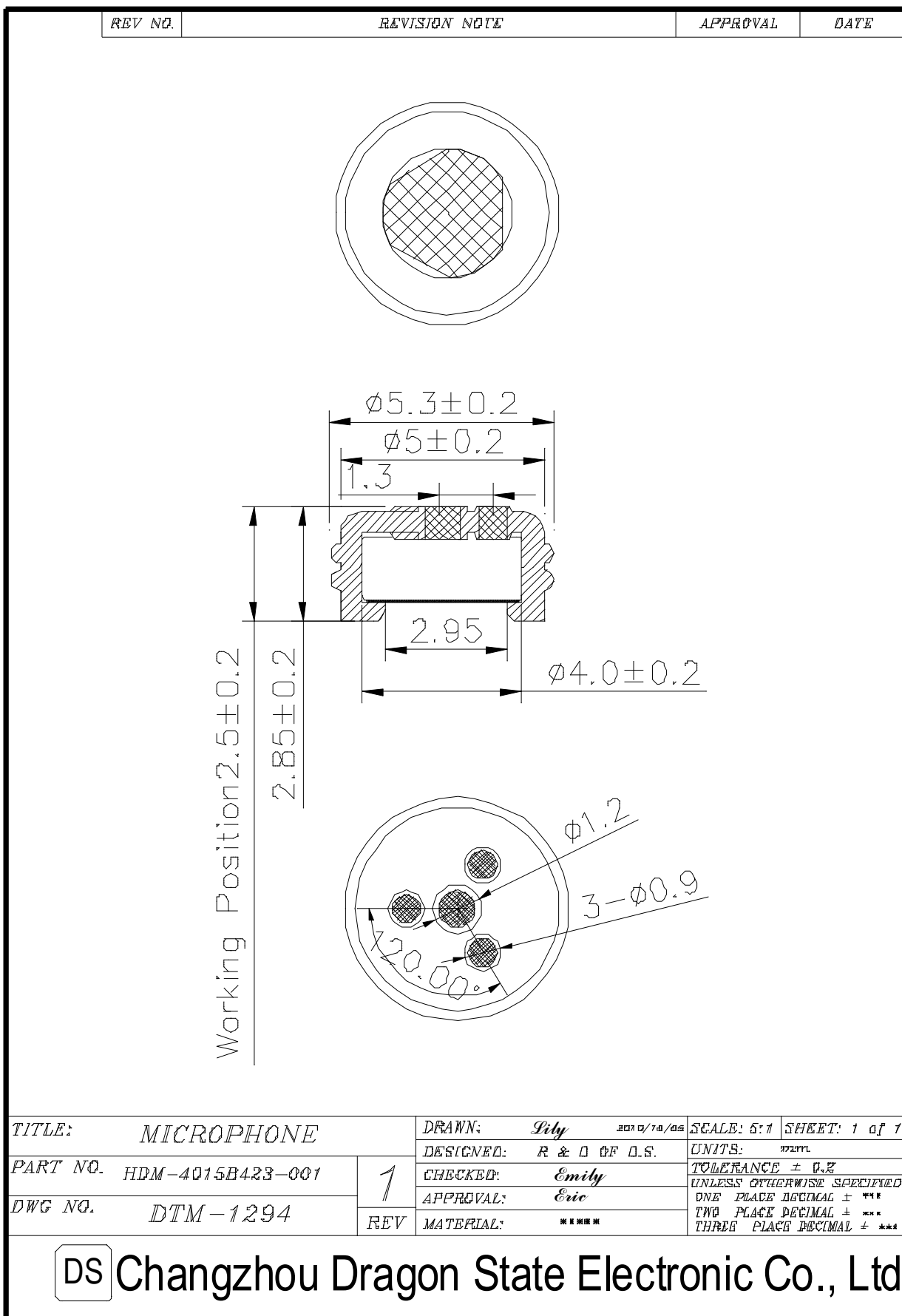



## 5. Reliability test

Item		Test Conditions	Evaluation Standard
01	High Temp. Test	After exposure at 70 °C for 100 hours, and expose to room temperature for 6 hours, sensitivity to be within $\pm 3$ dB from initial sensitivity.	After any tests , the sensitivity to be within $\pm 3$ dB of initial sensitivity after 3 hours of conditioning at 20 °C and shall keep their initial operation and appearance.
02	Low Temp. Test	After exposure at -25 °C for 100 hours, and expose to room temperature for 6 hours, sensitivity to be within $\pm 3$ dB from initial sensitivity.	
03	Temp.Cycle Test	After exposure at 70 °C for 1 hour, at room temp. for 1 hour, at -25 °C for 1 hour, at room temp. for 1 hour, at 10 cycles, and expose to room temp. for 6 hours, sensitivity to be within $\pm 3$ dB from initial sensitivity.	
04	Humidity Test	After exposure at 40 °C and 90 $\pm$ 5% relative humidity for 240 hours, and expose to room temperature for 6 hours, sensitivity to be within $\pm 3$ dB from initial sensitivity.	
05	Vibration Test	The microphone unit must be subjected to each 30 minutes vibrations at three axes 3 mm dynamic rang. 1000cycles/minute.	
06	Drop test	The microphone unit without packaged must be subjected to each 3 drops at three axes from the height of 1 meter to 20mm thick hardwood.	
07	Pull Strength Test	The microphone assembly shall suffer no change from a pull strength of 0.5 kg for 3 seconds applied between the connector and the microphone.	Application of the “pin” type

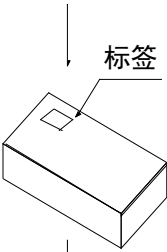
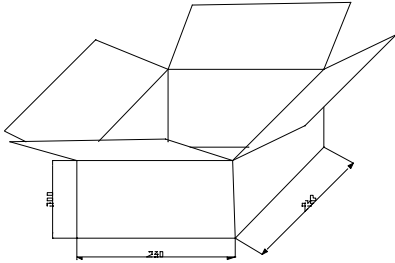
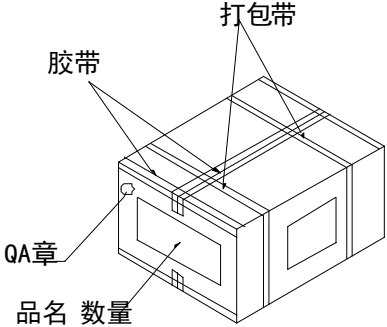
6. Packing

REV NO.	REVISION NOTE	APPROVAL	DATE
	 <p>Bag(100*100mm) 100pcs Material: Plastic</p>		
	 <p>标签 Middle(215*105*55mm) 1000pcs(10*100pcs) Material: Paper</p>		
	 <p>Outer Box(230*230*300mm) 10000pcs(10*1000pcs) Material: Paper</p>		
	 <p>打包带 胶带 QA章 品名 数量</p>		
TITLE: 包装方式		DRAWN: Lily 2006/05/23	SCALE: 1:10 SHEET: 1 of 1
PART NO.		DESIGNED: R & D of D.S.	UNITS: mm
DWG NO.		CHECKED: Emily	TOLERANCE ±5
		APPROVAL: Eric	UNLESS OTHERWISE SPECIFIED: ONE PLACE DECIMAL ± *** TWO PLACE DECIMAL ± **
REV		MATERIAL: 纸类	THREE PLACE DECIMAL ± ***
 <p>Changzhou Dragon State Electronic Co., Ltd</p>			