

## 18x11 MATRIX LED DRIVER WITH AUTO BREATH

### FEATURES

- 18 current sinks, 11 current switches, up to drive 198 LEDs or 66 RGBs.
- Programmable matrix size
- 3 pattern controllers for auto breathing or group PWM control
- Global 256-level DC current configuration
- Individual 256-level PWM for dimming
- Individual 256-level scaling current for color-mixing
- High-precision current sinks
  - Device-to-device error:  $\pm 5\%$
  - Channel-to-channel error:  $\pm 5\%$
- EMI and audible noise reduction
  - Phase control
  - Spread spectrum function
  - Programmable slew rate control
- Programmable H/L logic
  - 1.4V/0.4V
  - 2.4V/0.6V
- Individual 198 LEDs open/short detection
- Multiple-device clock synchronization by SYNC pin
- UVLO and over-temperature protection
- De-Ghost
- 1MHz I<sup>2</sup>C interface, 16 selectable addresses
- Power supply: 2.7V~5.5V
- QFN 5mmx5mmx0.55mm-40L package

### APPLICATIONS

Smart speaker, Bluetooth speaker  
Gaming device (Keyboard, Mouse etc.)  
Mobile phone, PAD

### GENERAL DESCRIPTION

AW20198 is an 18x11 matrix LED driver programmed via an I<sup>2</sup>C compatible interface. Each channel has individual 8-bit DC current setting for color-mixing and 8-bit PWM current setting for brightness control. The global current of each channel is configured via register GCCR and external resistor R<sub>EXT</sub>.

Three integrated pattern controllers provide auto breathing or group dimming control. Each pattern controller can work in auto breathing or manual control mode. All breathing parameters are configurable, including rising/falling slope, on/off time, repeat times, and minimum/maximum brightness, etc. Each LED's PWM parameter can be sourced from any one of the 3 pattern controllers optionally.

Phase-delay, phase-inverting, selectable three phase, spread spectrum and slew rate control technology are utilized to reduce EMI and audible noise caused by MLCC when LEDs turn on or off simultaneously.

AW20198 can be turned off with minimum current consumption by either pulling the EN pin low or using the software reset.

AW20198 is available in QFN 5mmx5mmx0.55mm-40L package. It operates from 2.7V to 5.5V over the temperature range of -40°C to +85°C.

## TYPICAL APPLICATION CIRCUIT

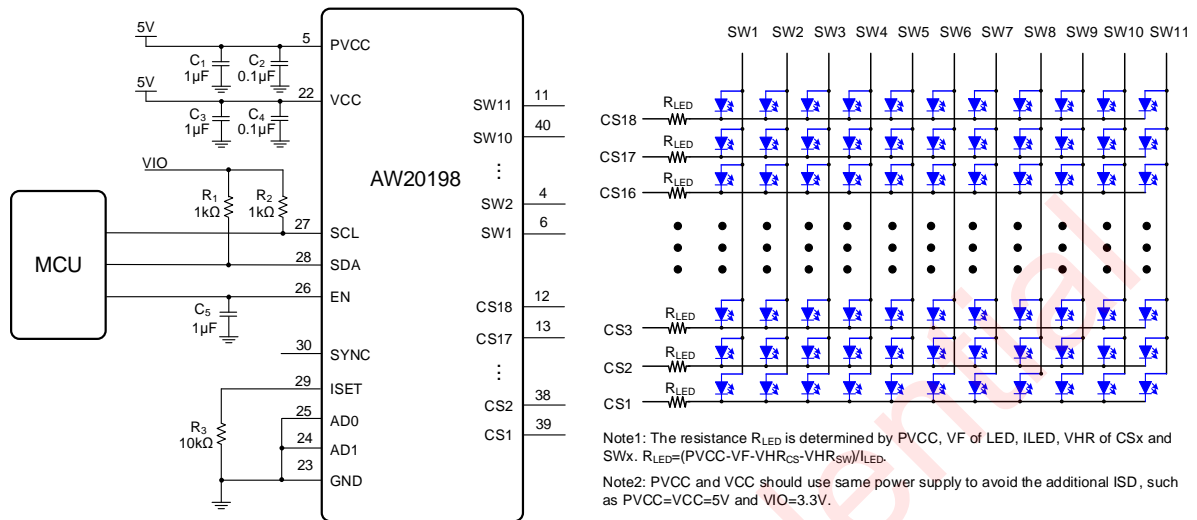

Figure 1 AW20198 Application Circuit

## PIN CONFIGURATION AND TOP MARK

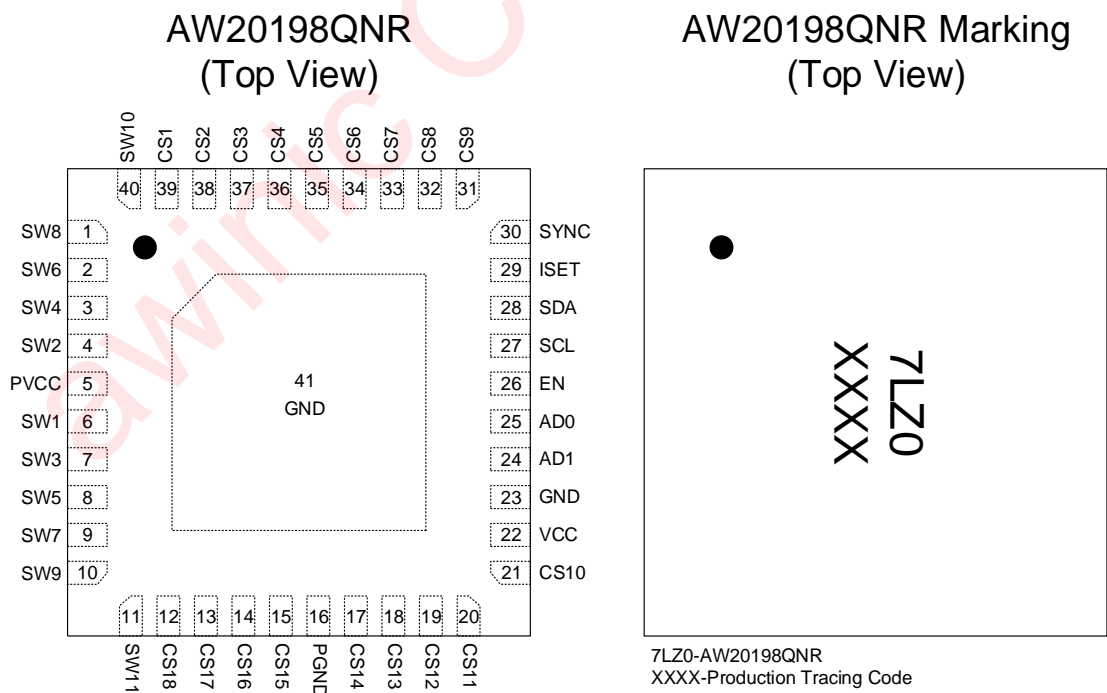

Figure 2 Pin Configuration and Top Marking

**PIN DEFINITION**

No.	NAME	DESCRIPTION
1~4	SW8, SW6, SW4, SW2	Current switches
5	PVCC	Current source power supply, 2.7V~5.5V
6~11	SW1, SW3, SW5, SW7, SW9, SW11	Current switches
12~15	CS18~CS15	Current sink
16	PGND	Power ground
17~21	CS14~CS10	Current sink
22	VCC	Power supply, 2.7V~5.5V
23	GND	Ground
24	AD1	I <sup>2</sup> C address select pin1
25	AD0	I <sup>2</sup> C address select pin0
26	EN	Standby the device when EN is low, internally pulled down to GND with a resistor of 1M $\Omega$
27	SCL	Serial clock input for I <sup>2</sup> C interface
28	SDA	Serial data I/O for I <sup>2</sup> C interface
29	ISET	When R <sub>EXT</sub> =10k $\Omega$ , global current of LED is 40mA
30	SYNC	Synchronize pin, used to synchronize clock in multiple devices application, internally pulled down to GND with a resistor of 1M $\Omega$
31~39	CS9~CS1	Current sink
40	SW10	Current switch
41	GND	Thermal pad

### FUNCTIONAL BLOCK DIAGRAM

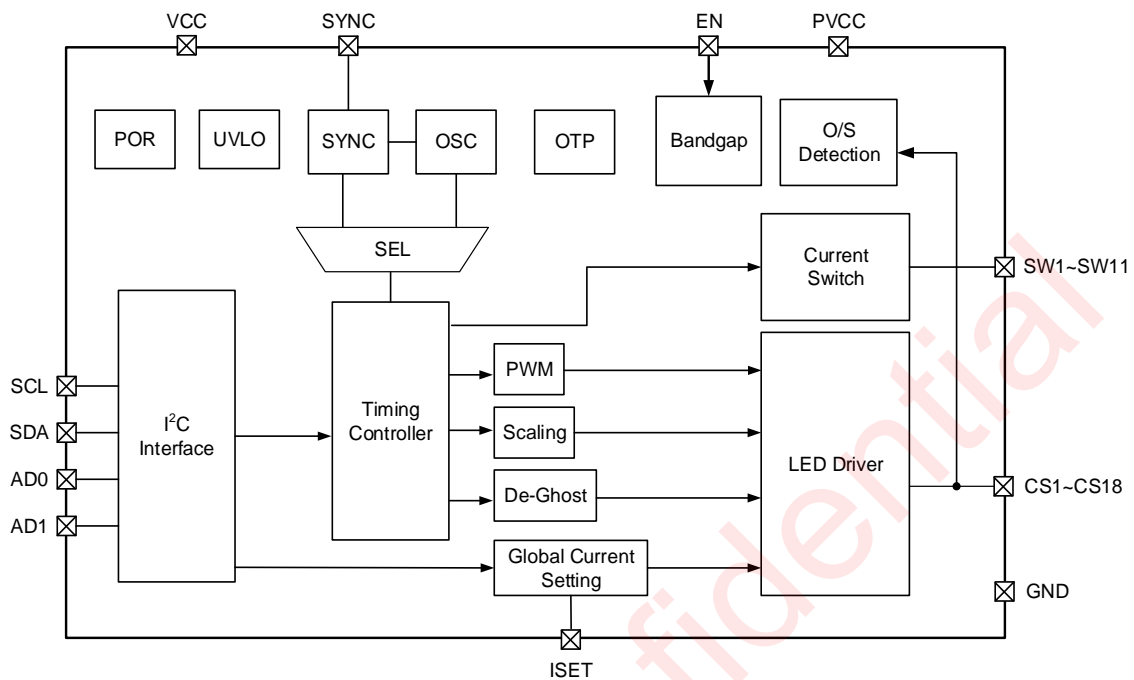

Figure 3 Functional Block Diagram

### TYPICAL APPLICATION CIRCUIT

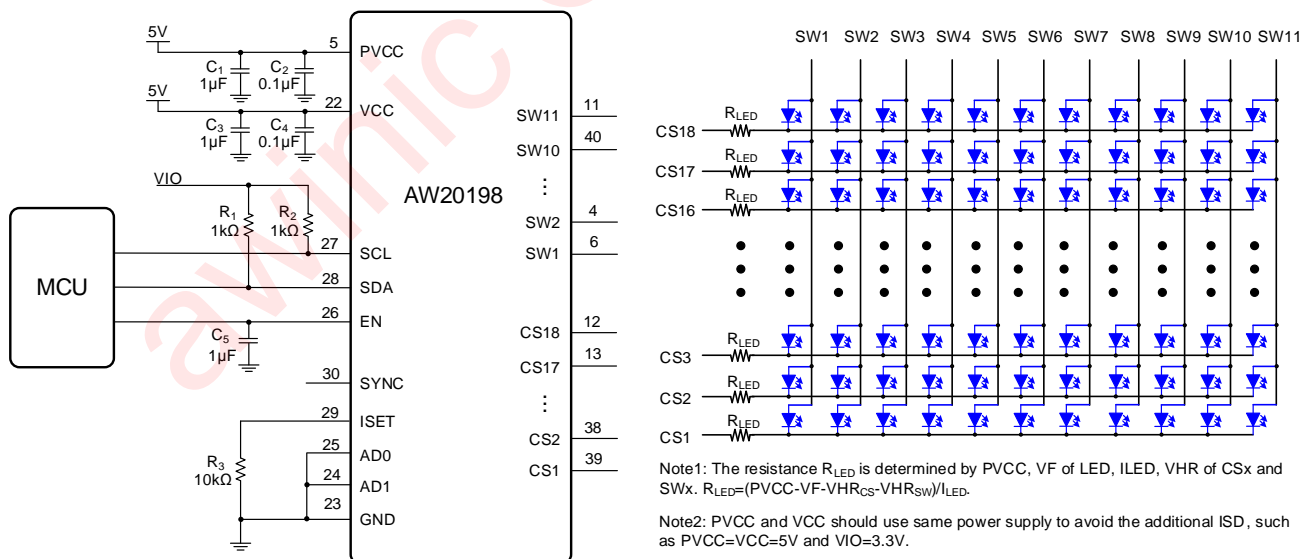

Figure 4 Typical Application Circuit

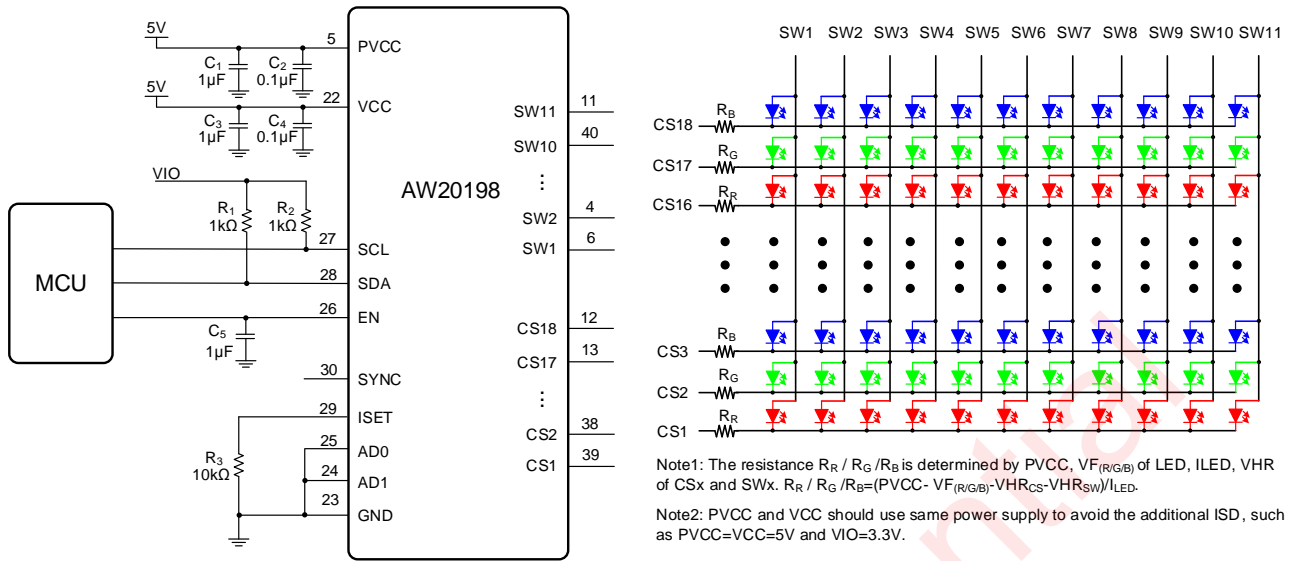

Figure 5 Typical Application Circuit (RGB)

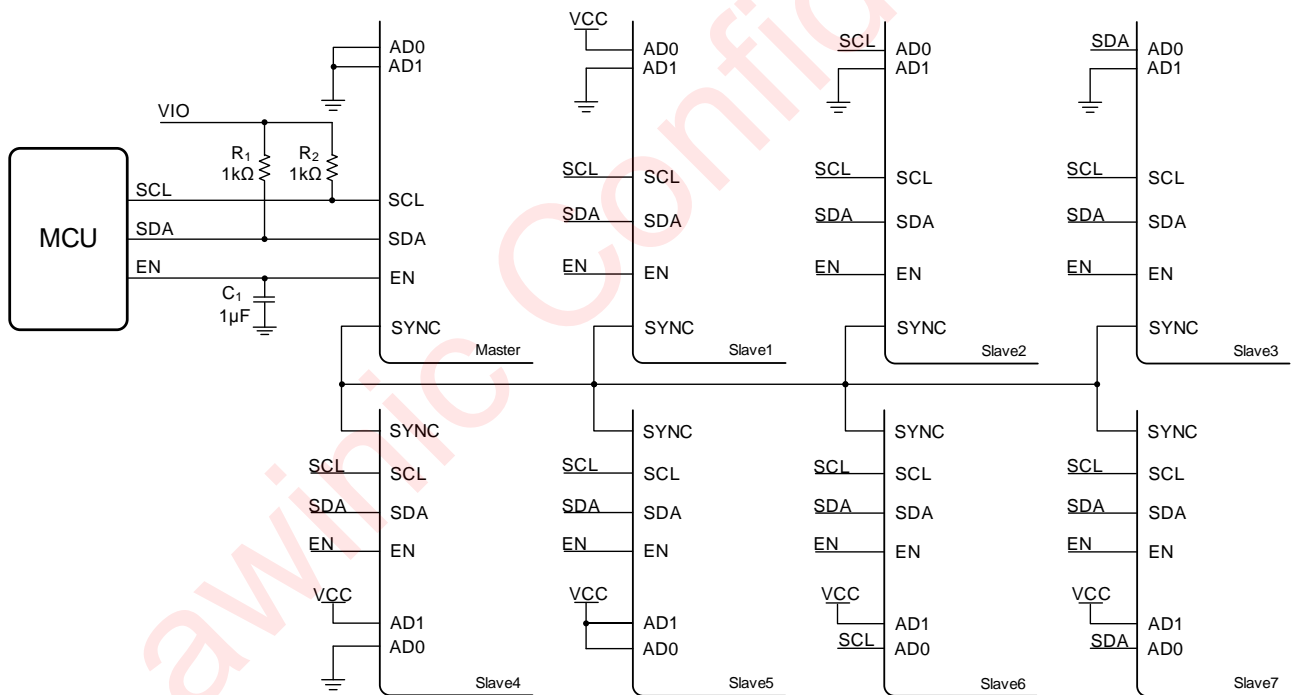

Figure 6 Typical Application Circuit (Eight Parts Synchronization)

## ORDERING INFORMATION

Part Number	Temperature	Package	Marking	Moisture Sensitivity Level	Environmental Information	Delivery Form
AW20198QNR	-40°C~85°C	QFN 5mmX5mm-40L	7LZ0	MSL3	ROHS+HF	6000 units/ Tape and Reel

## ABSOLUTE MAXIMUM RATINGS (NOTE1)

PARAMETERS		RANGE
Supply voltage range VCC		-0.3V to 6V
Supply voltage range PVCC		-0.3V to 6V
Input voltage range	SCL, SDA, EN, AD0, AD1	-0.3V to VCC
Output voltage range	SW1~SW11	-0.3V to PVCC
	CS1~CS18	-0.3V to VCC
Voltage on ISET	ISET	-0.3V to 2V
Junction-to-ambient thermal resistance $\theta_{JA}$		33°C/W
Operating free-air temperature range		-40°C to 85°C
Maximum operating junction temperature $T_{JMAX}$		160°C
Storage temperature $T_{STG}$		-65°C to 150°C
Lead temperature (soldering 10 seconds)		260°C
ESD (NOTE2)		
HBM		±2000V
CDM		±1500V
Latch-Up		
Test condition: JESD78E		±IT: 200mA

NOTE1: Conditions out of those ranges listed in "absolute maximum ratings" may cause permanent damages to the device. In spite of the limits above, functional operation conditions of the device should within the ranges listed in "recommended operating conditions". Exposure to absolute-maximum-rated conditions for prolonged periods may affect device reliability.

NOTE2: The human body model is a 100pF capacitor discharged through a 1.5kΩ resistor into each pin. Test method: ESDA/JEDEC JS-001-2017 (HBM). ESDA/JEDEC JS-002-2018 (CDM)

**ELECTRICAL CHARACTERISTICS**T<sub>A</sub>=25°C, PVCC=VCC=3.6V (unless otherwise noted), R<sub>EXT</sub>=10kΩ

PARAMETER		TEST CONDITION	MIN	TYP	MAX	UNIT
Power supply voltage and current						
VCC	Input operating range		2.7		5.5	V
I <sub>STB_VCC</sub>	Standby current	V <sub>EN</sub> =0V or CHIPEN=0		1.3		μA
I <sub>ACT_VCC</sub>	Quiescent current in active mode	V <sub>EN</sub> =VCC,CHIPEN=1, all LEDs off		1.8		mA
I <sub>MAX</sub>	Maximum sink current(CS1~CS18)	V <sub>LED</sub> =0.5V, GCC= 0xFF, SL= 0xFF		40		mA
V <sub>HR</sub>	Current switch headroom voltage SWx	I <sub>SWITCH</sub> =720mA, GCC=0xFF, SL=0xFF		750		mV
	Current sink headroom voltage CSx	I <sub>SINK</sub> =40mA, GCC=0xFF, SL=0xFF		300		mV
I <sub>LIM</sub>	Internal sink current limit	R <sub>EXT</sub> =0,UVCR.OCPH=0		75		mA
		R <sub>EXT</sub> =0,UVCR.OCPH=1		120		
I <sub>MATCH</sub>	Device to device current error	All Channels' current set to 40mA	-5		5	%
ΔI <sub>LED</sub>	Channel to channel current error	All Channels' current set to 40mA	-5		5	%
F <sub>OSC</sub>	OSC clock frequency		14.88	16	17.12	MHz
T <sub>SD</sub>	Thermal shutdown threshold			165		°C
	Thermal shutdown hysteresis			25		°C
LOGIC (SCL,SDA,AD0,AD1,EN)						
V <sub>IL</sub>	Input logic low	VCC=2.7V~5.5V,LGC=0			0.4	V
V <sub>IH</sub>	Input logic high	VCC=2.7V~5.5V,LGC=0	1.4			V
V <sub>IL</sub>	Input logic low	VCC=2.7V~5.5V,LGC=1			0.6	V
V <sub>IH</sub>	Input logic high	VCC=2.7V~5.5V,LGC=1	2.4			V
Timing						
T <sub>SCAN</sub>	Period of scanning	PCCR.PWMFRQ[2:0] = 000, GCR.SWSEL[3:0] = 1011		198		μs
T <sub>DG</sub>	Non-overlap time between SW			1		μs

PARAMETER		TEST CONDITION	MIN	TYP	MAX	UNIT
T <sub>HOLD</sub>	Delay time between the falling edge of CS18 and SWx			125		ns
T <sub>SETUP</sub>	Delay time between the rising edge of SWx and CS1	PCCR.PWMFRQ[2:0] = 000		250		ns
T <sub>DLY</sub>	Delay time of each CS group, there are 6 groups of CS	PCCR.PWMFRQ[2:0] = 000		125		ns

awinic Confidential

**I<sup>2</sup>C INTERFACE TIMING**

PARAMETER		FAST MODE			FAST MODE PLUS			UNIT
		MIN	TYP	MAX	MIN	TYP	MAX	
F <sub>SCL</sub>	Interface clock frequency	-		400	-		1000	kHz
T <sub>HD:STA</sub>	(Repeat-start) Start condition hold time	0.6		-	0.26		-	μs
T <sub>LOW</sub>	Low level width of SCL	1.3		-	0.5		-	μs
T <sub>HIGH</sub>	High level width of SCL	0.6		-	0.26		-	μs
T <sub>SU:STA</sub>	(Repeat-start) Start condition setup time	0.6		-	0.26		-	μs
T <sub>HD:DAT</sub>	Data hold time	0		-	0		-	μs
T <sub>SU:DAT</sub>	Data setup time	0.1		-	0.05		-	μs
T <sub>R</sub>	Rising time of SDA and SCL	-		0.3	-		0.12	μs
T <sub>F</sub>	Falling time of SDA and SCL	-		0.3	-		0.12	μs
T <sub>SU:STO</sub>	Stop condition setup time	0.6		-	0.26		-	μs
T <sub>BUF</sub>	Time between start and stop condition	1.3		-	0.5		-	μs

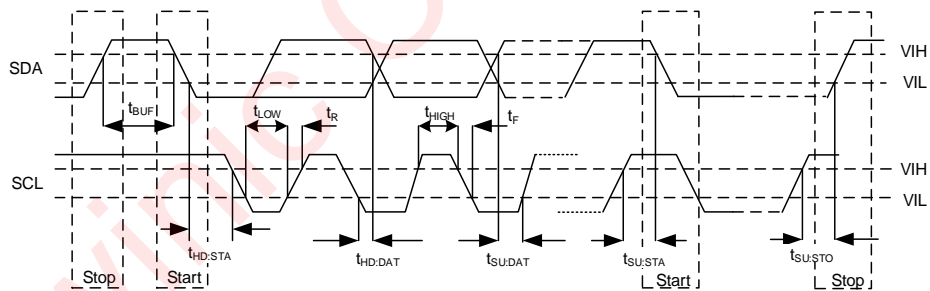
**Figure 7 I<sup>2</sup>C Interface Timing**

## DETAILED FUNCTIONAL DESCRIPTION

### OPERATION MODE AND RESET

#### POWER ON RESET (POR)

During initial power-up, AW20198 is reset, and all registers are reset to default value, and LED driver is shut down.

Once the supply voltage VCC drops below the threshold voltage  $V_{POR\_VCC}$  (2.0V), the power-on-reset will be activated to reset the device again. By reading the bit PUST of the register UVCR (page0, address=0x2A), it can be determined whether the device has been reset.

Below is the recommended operation timing:

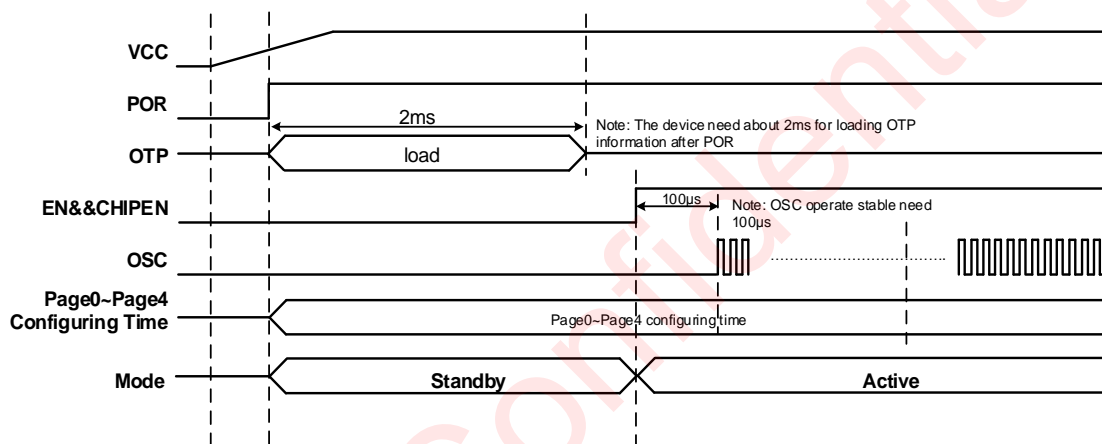

Figure 8 Power up Timing

#### SOFTWARE RESET

By writing 0xAE to register RSTN (page0, address=0x2F), the software reset is triggered. After software reset, all registers will be reset to the default value and enter into standby mode.

After the software reset command is input through I<sup>2</sup>C or power on reset, it needs to wait at least 2ms before any other I<sup>2</sup>C command can be accepted.

#### STANDBY MODE

When EN is pulled low or the bit CHIPEN of the register GCR (page0, address=0x00) is set to "0" or UVLO is triggered (UVFLG=1) in active mode or OT is active, AW20198 enters into standby mode automatically. In standby mode, all analog blocks are power down but the registers retain the data and keep it available via I<sup>2</sup>C.

When POR is triggered, the device enters into standby mode and all registers will be reset (more information is showed in POWER ON RESET).

#### ACTIVE MODE

When EN is in high level, and the bit CHIPEN of the register GCR (page0, address=0x00) is set to "1", AW20198 enters into the active mode.

#### LOW POWER MODE

The bit LPEN of the register MIXCR (page0, address=0x46) is set to "1", the low power mode is enabled. When all PWM[7:0] are 0x00 in active frame, AW20198 automatically enters into low power mode for power saving.

If any bit of PWM[7:0] is not 0 in active frame, the device exits low power mode immediately.

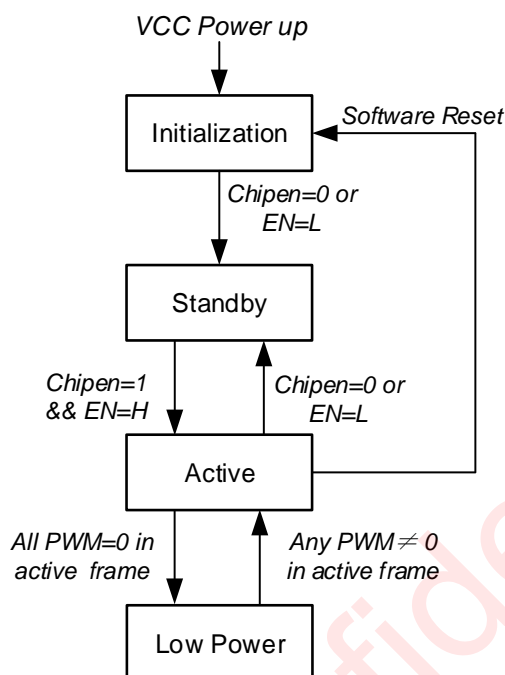

Figure 9 AW20198 Operating Mode Transition

## I<sup>2</sup>C INTERFACE

AW20198 supports the I<sup>2</sup>C protocol. The maximum frequency supported by the I<sup>2</sup>C is 1MHz. The pull-up resistor for the SDA and SCL can be selected from 1k to 10kΩ. Usually, 4.7kΩ is recommended for 400 kHz I<sup>2</sup>C, 1kΩ is recommended for 1MHz I<sup>2</sup>C. The voltage from 1.8V to 3.3V is allowed for the I<sup>2</sup>C interface. Additionally, the I<sup>2</sup>C device supports continuous read and write operations.

## DEVICE ADDRESS

The I<sup>2</sup>C device address is 7-bit (A7~A1), followed by the R/W bit A0 (Read=1/Write=0). Set A0 to “0” for writing and “1” for reading. The values of bits A4:A3 and bits A2:A1 are depended on the connection of pin AD1 and AD0. Separately, there are 4 options: VCC, GND, SCL and SDA. The A7 to A5 is “010” constantly. The device also supports using a broadcast slave address of 0x5A to access registers. All slave addresses as followed.

AD0	AD1	A7:A5	A4:A3	A2:A1	A0	Device Address	Broadcast Address
GND	GND	010	00	00	0/1	0x20	0x5A
GND	VCC		00	01		0x21	
GND	SCL		00	10		0x22	
GND	SDA		00	11		0x23	
VCC	GND		01	00		0x24	
VCC	VCC		01	01		0x25	
VCC	SCL		01	10		0x26	
VCC	SDA		01	11		0x27	
SCL	GND	10	00	0x28			

AD0	AD1	A7:A5	A4:A3	A2:A1	A0	Device Address	Broadcast Address
SCL	VCC	010	10	01	0/1	0x29	0x5A
SCL	SCL		10	10		0x2A	
SCL	SDA		10	11		0x2B	
SDA	GND		11	00		0x2C	
SDA	VCC		11	01		0x2D	
SDA	SCL		11	10		0x2E	
SDA	SDA		11	11		0x2F	

### I<sup>2</sup>C START/STOP

I<sup>2</sup>C start: SDA changes from high level to low level when SCL is high level.

I<sup>2</sup>C stop: SDA changes from low level to high level when SCL is high level.

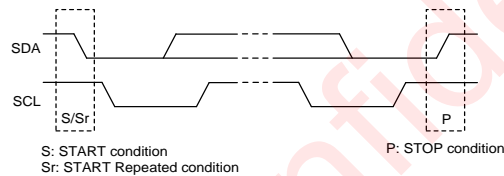

Figure 10 I<sup>2</sup>C Start/Stop Condition Timing

### DATA VALIDATION

When SCL is high level, SDA level must be constant. SDA can be changed only when SCL is low level.

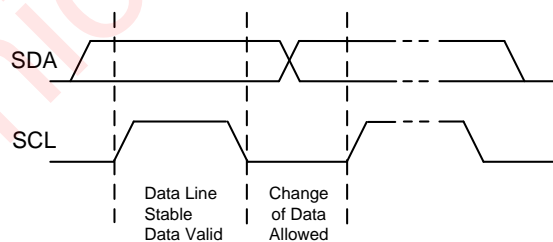
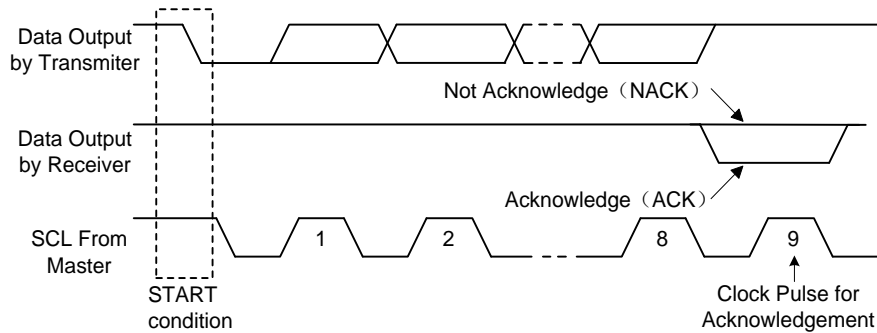

Figure 11 Data Validation Diagram

### ACK (ACKNOWLEDGEMENT)

ACK means the successful transfer of I<sup>2</sup>C bus data. After master sends an 8-bit data, SDA must be released; SDA is pulled to GND by slave device when slave acknowledges.

When master reads, slave device sends 8-bit data, releases the SDA and waits for ACK from master. If ACK is send and I<sup>2</sup>C stop is not send by master, slave device sends the next data. If ACK is not send by master, slave device stops to send data and waits for I<sup>2</sup>C stop.

Figure 12 I<sup>2</sup>C ACK Timing

### WRITE CYCLE

One data bit is transferred during each clock pulse. Data is sampled during the high state of the serial clock (SCL). Consequently, throughout the clock's high period, the data should remain stable. Any changes on the SDA line during the high state of the SCL and in the middle of a transaction, aborts the current transaction. New data should be sent during the low SCL state. This protocol allows a single data line to transfer both command/control information and data using the synchronous serial clock.

Each data transaction is composed of a start condition, a number of byte transfers (set by the software) and a stop condition to terminate the transaction. Every byte written to the SDA bus must be 8 bits long and is transferred with the most significant bit first. After each byte, an Acknowledge signal must follow.

In a write process, the following steps should be followed:

- Master device generates START condition. The "START" signal is generated by lowering the SDA signal while the SCL signal is high.
- Master device sends slave address (7-bit) and the data direction bit R/W = 0).
- Slave device sends acknowledge signal if the slave address is correct.
- Master sends control register address (8-bit).
- Slave sends acknowledge signal.
- Master sends data byte to be written to the addressed register.
- Slave sends acknowledge signal.
- If master will send further data bytes the control register address will be incremented by one after acknowledge signal (repeat step f and g).
- Master generates STOP condition to indicate write cycle end.

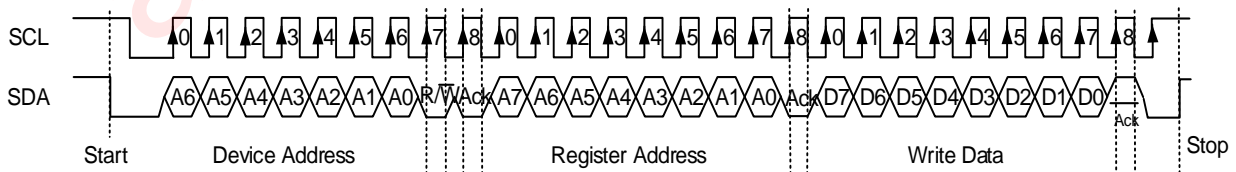
Figure 13 I<sup>2</sup>C Write Byte Cycle

**READ CYCLE**

In a read cycle, the following steps should be followed:

- Master device generates START condition.
- Master device sends slave address (7-bit) and the data direction bit ( $R/W = 0$ ).
- Slave device sends acknowledge signal if the slave address is correct.
- Master sends control register address (8-bit).
- Slave sends acknowledge signal.
- Master generates STOP condition followed with START condition or REPEAT START condition.
- Master device sends slave address (7-bit) and the data direction bit ( $R/W = 1$ ).
- Slave device sends acknowledge signal if the slave address is correct.
- Slave sends data byte from addressed register.
- If the master device sends acknowledge signal, the slave device will increase the control register address by one, then send the next data from the new addressed register.
- If the master device generates STOP condition, the read cycle is ended.

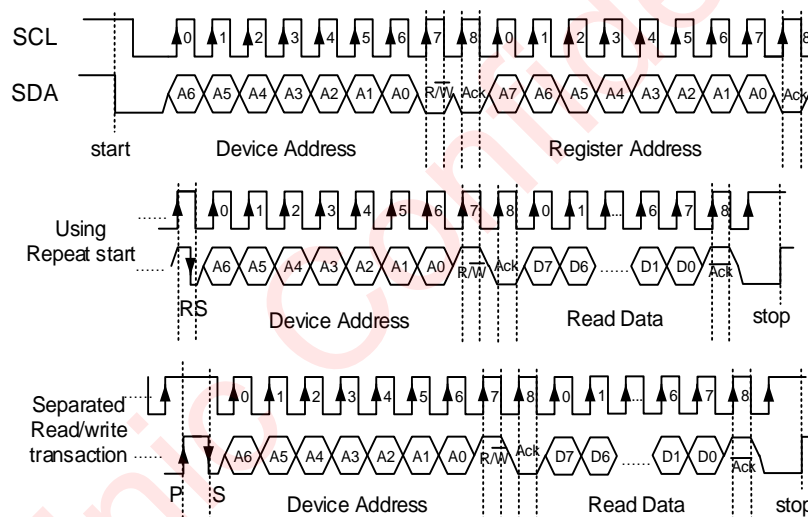

**Figure 14 I<sup>2</sup>C Read Byte Cycle**

**UNDER VOLTAGE LOCK OUT (UVLO)**

When bit UVDIS of the register UVCR (page0, address=0x2A) is set to “0”, the device monitors the voltage of VCC. If the voltage drops below threshold (2.5V typically), the bit UVFLG of the register UVCR (page0, address=0x2A) will be set to “1”. After read-out, the bit UVFLG will be clear.

If both bit UVDIS and bit UVPD of the register UVCR (page0, address=0x2A) are set to “0”, UVLO protection function is enabled. Once the event of under voltage occurs, the bit CHIPEN of the register GCR (page0, address=0x00) will be cleared to “0”, and then the device will enter into standby mode. If the voltage of VCC rises above the UVLO threshold and then write “1” to bit CHIPEN, the device will enter into active mode again. By default, control bits UVDIS, UVPD are all “0”. Both UVLO monitor and protection are enabled.

## OVER TEMPERATURE PROTECTION (OTP)

### OVER TEMPERATURE ROLL OFF

The bits TRTH[1:0] and bits TROF[1:0] of register OTCR (page0, address=0x27) are thermal roll off threshold temperature and thermal roll off percentage of  $I_{OUT}$  respectively. The threshold temperature can be configured as 140°C, 120°C, 100°C or 90°C. Thermal roll off percentage can be configured as 100%, 75%, 50% or 30%. When set the bits TRTH[1:0] to be “00” and set bits TROF[1:0] to be “10”, the thermal roll off threshold temperature is “140°C”. Once the temperature is over 140°C, the flag bit TRFLG of register OTCR (page0, address=0x27) is set to “1”, and  $I_{OUT}$  will be decreased to its 75%.

### OVER TEMPERATURE ALL LED IS OFF

When bit OTDIS of the register OTCR (page0, address=0x27) is set to “0”, the over-temperature detection is enabled. Once the temperature of this device reaches 165°C, the over-temperature condition is detected, and the bit OTFLG of the register OTCR (page0, address=0x27) will be set to “1”. The OTFLG will be cleared to “0” after reading the register OTCR.

If both bit OTDIS and bit OTPD of the register OTCR (page0, address=0x27) are set to “0”, the Over-Temperature Protection (OTP) function is enabled. Once the temperature is over 165°C, the bit CHIPEN of the register GCR (page0, address=0x00) will be cleared to “0”, and then the device will enter into standby mode. When the temperature returns below 140°C, the device will enter into active mode again after writing “1” to bit CHIPEN.

By default, control bits OTDIS and OTPD are all “0”, both OT monitor and OT protection are enable.

## LED OPEN/SHORT DETECTION

AW20198 supports LED open/short detection. When bits OSDE[1:0] of the register GCR (page0, address=0x00) are set to “11”, open detection is enabled, and the detection results can be read out via the registers OSR0~OSR32 (page0, address=0x03~0x23) when CHIPEN is “1”. Similarly, when set bits OSDE[1:0] of the register GCR (page0, address=0x00) to “10”, short detection is enabled, and the results also can be read out via the registers OSR0~OSR32 when CHIPEN is “1”. Each bit of OSR0~OSR32 store a LED's open/short status. Each OSR register stores 6 LEDs open/short status in bit5~bit0. For example, OSR0 stores the status of LED0~LED5, in which MSB is status of LED5, and LSB is status of LED0.

	CS1	CS2	CS3	CS4	CS5	CS6	CS7	CS8	CS9	CS10	CS11	CS12	CS13	CS14	CS15	CS16	CS17	CS18
SW1	OSR0						OSR1						OSR2					
SW2	OSR3						OSR4						OSR5					
SW3	OSR6						OSR7						OSR8					
SW4	OSR9						OSR10						OSR11					
SW5	OSR12						OSR13						OSR14					
SW6	OSR15						OSR16						OSR17					
SW7	OSR18						OSR19						OSR20					
SW8	OSR21						OSR22						OSR23					
SW9	OSR24						OSR25						OSR26					
SW10	OSR27						OSR28						OSR29					
SW11	OSR30						OSR31						OSR32					

Figure 15 Open/Short Register

The valid detect result is determined by:

Short detection:  $V_{CS} > PVCC - V_{TH_{SHORT}}$

Open detection:  $V_{cs} < V_{THOPEN}$

$V_{THSHORT}$ : Threshold of short detection ( $V_{THSHORT} = 1.5V$ , typical).

$V_{THOPEN}$ : Threshold of open detection ( $V_{THOPEN} = 0.1V$ , typical).

The recommend configuration in  $PVCC=4.2V$  is:

- $PSEL[1:0] = 2'b00$ , (page0.PCCR[1:0]);
- $0x05 \leq GCC[7:0] \leq 0x80$ , (page0.GCCR);
- $0x20 \leq PWM[7:0] \leq 0xFF$ , (page1.PWMn,  $n=0\sim197$ );
- $SL=0xFF$ , (page2.SLn,  $n=0\sim197$ );

## LED DISPLAY AND CONTROL

### LED DISPLAY CONTROL DESCRIPTION

The device supports up to 198 LEDs. The location of each LED is shown by the following figure. The parameter location in page1~page3 is the same as the LED.

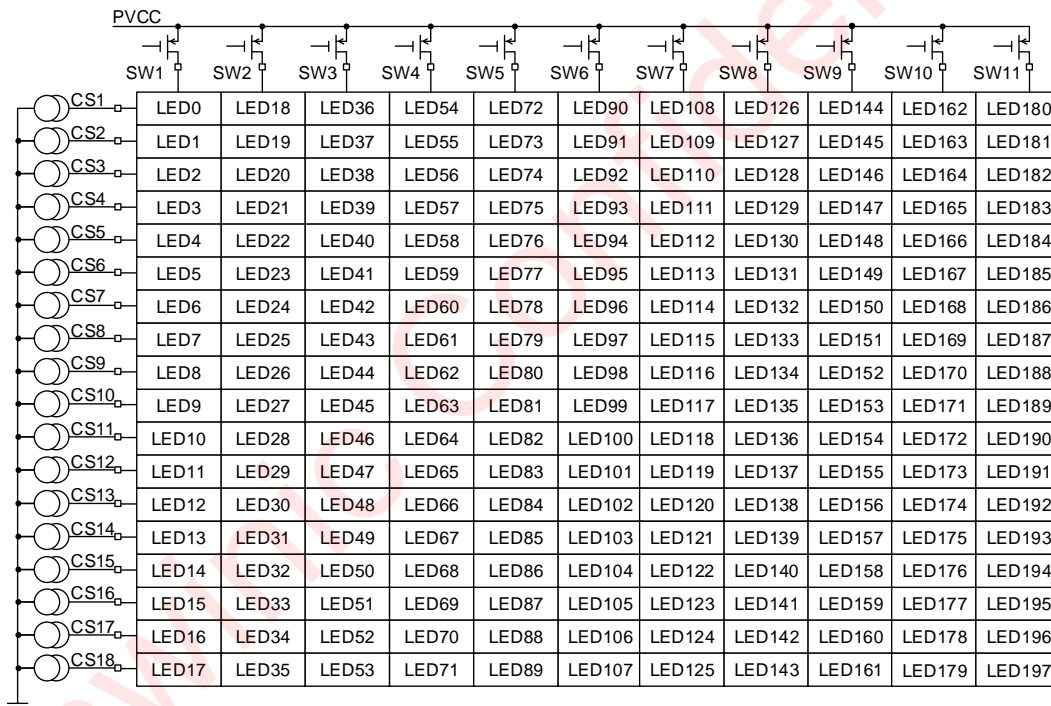
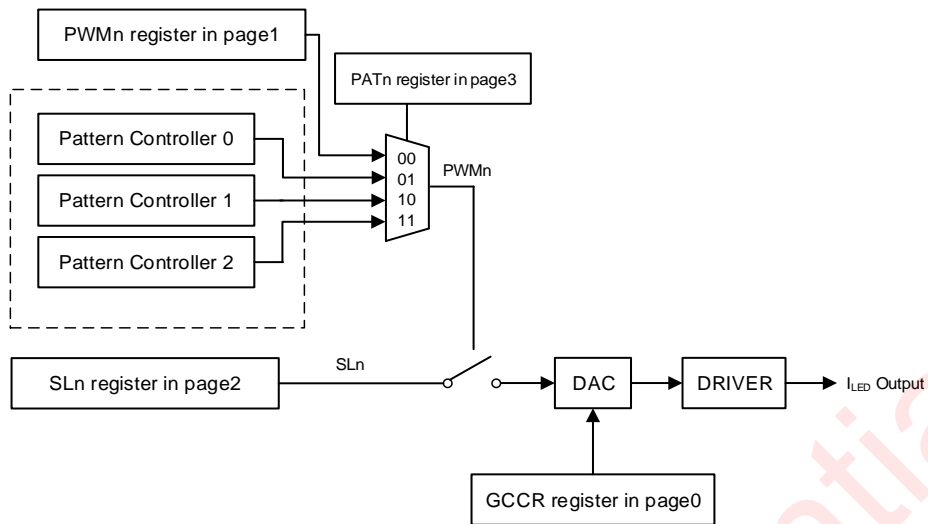

Figure 16 LED Location

In AW20198, each LED is controlled by 4 independent parameters:

- $GCC[7:0]$  control, Global Current Control, register GCCR (page0, address=0x01);
- $PWM[7:0]$  control, register PWMn (page1, address=0x00~0xC5,  $n=0\sim197$ )
- $SL[7:0]$  control, register SLn (page2, address=0x00~0xC5,  $n=0\sim197$ )
- $PAT[1:0]$  selection, PAT choice, register PATn (page3, address= 0x00~0x41,  $n=0\sim197$ )

User can program above parameters to control each LED. Register PWM can control the brightness of LEDs, register SL can control the constant current and register GCCR can adjust the global current. Via configuring registers PATn ( $n=0\sim197$ ), Each LED can be controlled by an internal pattern controller (PAT0, PAT1, PAT2) to dimming synchronously or output the same breathing lighting effect. A group PAT of LEDs controlled by register PATGn ( $n=0\sim65$ ) which contains 3 adjacent LEDs. The figure below shows the LED current control model of AW20198.



**Figure 17 LED Current Control Model**

The device supports multiple parameters fast updating. The PWM, SL and PAT parameters of each LED are distributed in page1, page2 and page3 respectively. The page4 is virtual page. In page4, PWM and SL parameter of each LED are put together, so it is easy to update both PWM and SL in the order of LED in very short time via one continuous write operation of I<sup>2</sup>C. The following figure shows the distribution of display parameter in different page.

page1 (addr: 0xC1)				page2 (addr: 0xC2)	
0x00	PWM0			0x00	SL0
0x01	PWM1			0x01	SL1
0x02	PWM2			0x02	SL2
	.....				.....
0xC5	PWM197			0xC5	SL197

page3 (addr: 0xC3)				page4 (addr: 0xC4)			
0x00	PAT2	PAT1	PAT0	PATG0	0x00	PWM0	SL0
0x01	PAT5	PAT4	PAT3	PATG1	0x01	PWM1	SL1
0x02	PAT8	PAT7	PAT6	PATG2	0x02	PWM2	SL2
	...	...	...			.....	.....
0x41	PAT197	PAT196	PAT195	PATG65	0xC5	PWM197	SL197

**Figure 18 Display Parameter Distribution in Page1~Page4**

**SCANNING TIMING****Figure 19 Scanning Timing**

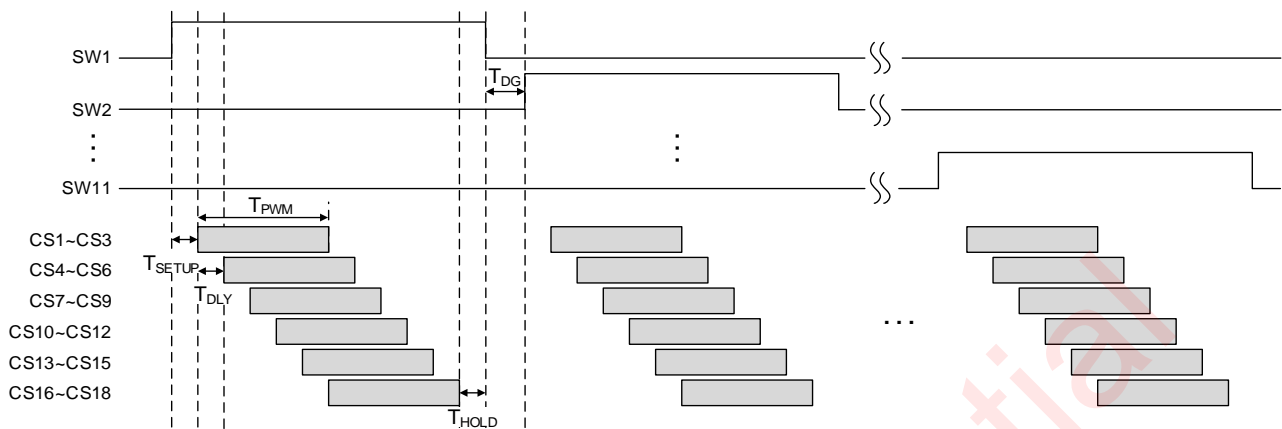
As shown in scanning timing figure, the SW1~SW11 is turned on by serial, LED is driven by CS1~CS18 within the SWx (x=1~11) active time. The non-overlap between SW is de-ghost time,  $T_{DG}$ .  $T_{SETUP}$  is the time between the rising edge of SWx and CS1. SW Control 18 channels current sink (CS1~CS18). CS are divided into 6 groups, and each group has a delay time,  $T_{DLY}$ .  $T_{PWM}$  is PWM active time when the register  $PWM_n=0xFF$  ( $n=0\sim197$ ), and  $T_{HOLD}$  is the time between the falling edge of CS18 and SWx. In addition, SW scanning number N ( $N=1\sim11$ ) can be controlled by bits SWSEL[3:0] in register GCR.

When SWSEL[3:0]=0000, PCCR.PWMFRQ[2:0] = 000 (page0, address=0x29), the DUTY is:

$$DUTY = \frac{15.9375\mu s}{0.25\mu s + 5 \times 0.125\mu s + 16\mu s + 0.125\mu s + 1\mu s} \times \frac{1}{11} = 0.0805$$

Where  $T_{PWM} = 15.9375\mu s$ ,  $T_{SETUP} = 0.25\mu s$ ,  $T_{DLY} = 0.125\mu s$ ,  $T_{HOLD} = 0.125\mu s$ , and  $T_{DG} = 1\mu s$ . The period of PWM is 16 $\mu s$ .

The average output current of LED<sub>n</sub> ( $n=0\sim197$ ) can be expressed by the following formula,

$$I_{LED} = \frac{K}{R_{EXT}} \times \frac{GCC}{255} \times \frac{SL_n}{255} \times \frac{PWM_n}{256} \times DUTY$$

Where  $K = 400V$ , and  $R_{EXT}$  is the value of external resistor.

**PWM MODULATION****PWM FREQUENCY**

The PWM frequency is decided by bits PWMFRQ[2:0] of register PCCR (page0, address=0x29). Following table shows the relationship of PWM frequency and the PWMFRQ[2:0]. To avoid the MLCC audible noise, it's recommended to use the PWM frequency higher than 20 kHz.

PWMFRQ[2:0]	000	001	010	011	100	101	110	111
PWM Freq.	62.5kHz	31.25kHz	15.6kHz	7.8kHz	3.9kHz	1.95kHz	975Hz	488Hz

**PWM PHASE CONTROL**

To reduce the peak load current and ceramic-capacitor audible ringing, AW20198 supports 6 groups phase

delay, phase inverting and three-phase mode. When the bits PSEL[1:0] in register PCCR (page0, address=0x29) is "00", the 6 group PWM phase-delay scheme is enabled, which means only 3 of 18 LEDs could switch on in the same time. The following figure shows the timing of phase delay mode.

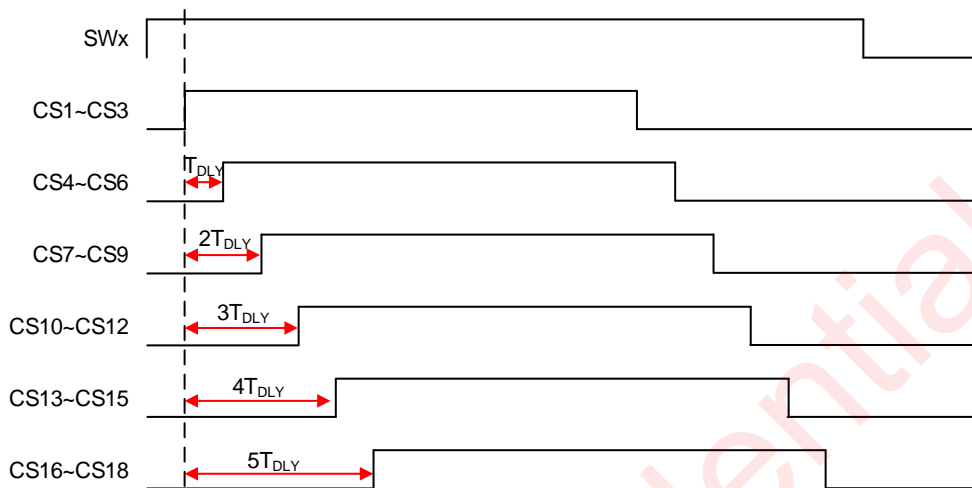

Figure 20 Phase Delay Mode

When setting the PSEL[1:0] to "01", the PWM phase of the even-numbered channels is inverted on the basis of phase-delay, as shown figure phase inverting mode. When setting the PSEL[1:0] to "10/11", three-phase mode is enabled, as shown figure three-phase mode. Phase delay, phase inverting and three-phase mode reduce the number of switch-on LEDs at the same time, which is good for reducing the input-current ripple.

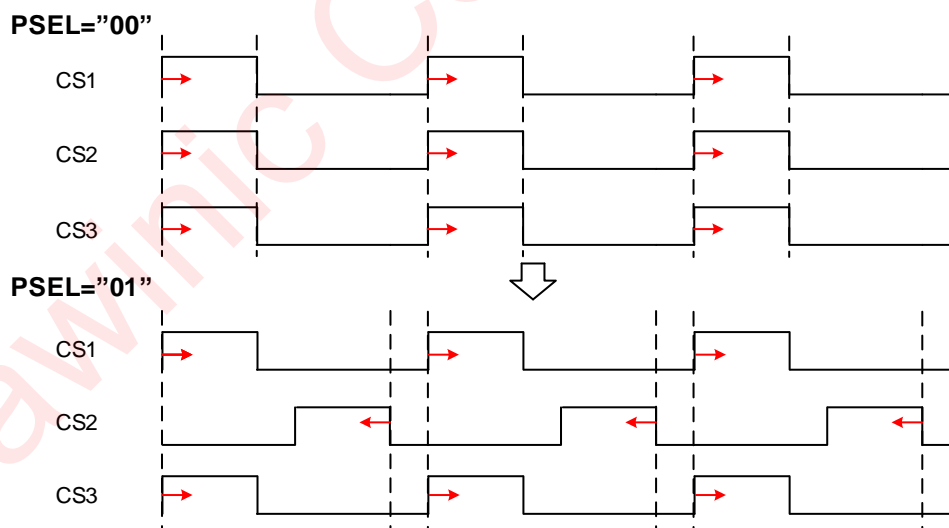

Figure 21 Phase Inverting Mode

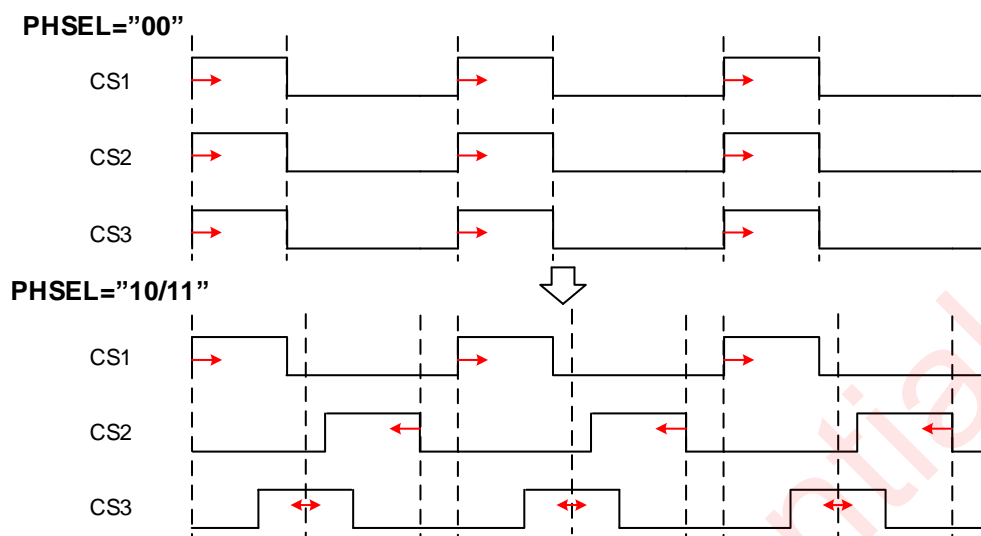

Figure 22 Three-Phase Mode

## EMI REDUCTION

### SLEW RATE

AW20198 supports programmed slew rate control, which can change the transition time of the LED current sink (CS1~CS18) on or off, so as to achieve the effect of reducing EMI. The slew rate control is configured by the bits SRR and SRF[1:0] of register SRCR(page0, address=0x2B).

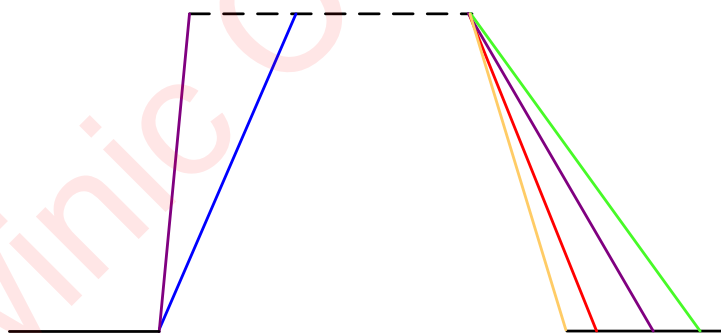

Figure 23 Slew Rate Control

### SPREAD SPECTRUM

AW20198 has spread spectrum function to optimize the EMI performance. If bit SSE in register SSCR (page0, address=0x28) is set to "1", spread spectrum function is enabled. By setting the bit SSR in register SSCR (page0, address=0x28), four spread spectrum range 5%, 15%, 25% and 35% can be selected. The total electromagnetic emitting energy can spread into a wider range of frequency band that significantly degrades the peak energy of EMI.

### DE-GHOST FUNCTION

To prevent the LED ghost effect, AW20198 has integrated pull down resistors for each SWx (x=1~11) and pull up resistors for each CSx (x=1~18). The bits CSPUR[2:0] and SWPDR[2:0] of register DGCR (page0, address=0x02) can select the CSx pull up resistor and SWx pull down resistor, separately. The bits PUMD and

PDMD of register DGCR (page0, address=0x02) can select the operating mode of de-ghost resistors. When the bit PUMD is "0", the CSx pull up resistor only work at CSx turning-off time. When the bit PUMD is "1", the CSx pull up resistor work all the time. Similarly, PDMD functions are the same as PUMD. Only when the SWx pull down resistors and CSx pull up resistors are active at the CSx/SWx output turning-off time, there is no power loss through these resistors.

## PATTERN CONTROLLERS

There is a breathing pattern controller (BPC) in the device, it has three patterns (PAT0~PAT2). Each LED can be configured different patterns by Page3 (PAT choice register), each register can control three LEDs, and each LED have three patterns (00: PWM, 01: PAT0, 10: PAT1, 11: PAT2). Page3 has 66 registers (66x3). PAT0CFG~PAT2CFG (page0, address=0x42~0x44) are PAT0~PAT2 configure registers. When bit PATEN in register PATxCFG (x=0~2) is set to "1", breathing pattern controller is enabled. Pattern controller can be configured as autonomous breathing mode or manual-controlled mode.

### AUTONOMOUS BREATHING MODE

When PATEN is set to "1", the pattern controller works in autonomous breathing mode. In this mode, the pattern controller will generate a breathing lighting effect, which is configured by the user-defined timing parameter. The waveform of the breathing lighting effect is shown in the following figure. The parameter T0~T3 define 4 key periods in a complete breathing cycle. T0~T3 composite a breathing loop, denoting the rise-time, on-time, fall-time and off-time respectively. Register PWMxH (x=0~2, page0, address=0x30~0x32) and PWMxL (x=0~2, page0, address=0x33~0x35) control the maximum and minimum brightness of the breathing, respectively. When bit LOGEN in register PATxCFG (x=0~2) is set to "1", the lighting effects switch to logarithmic mode. In the logarithmic mode, the lighting effect is smoother than the linear mode during T0 and T2, and causes the change in intensity to appear more linear to the human eye.

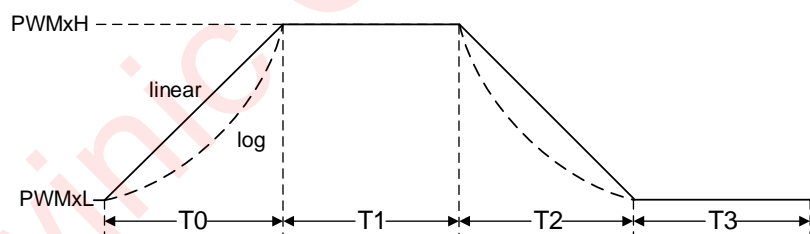

Figure 24 LED Breath Timing in Pattern Mode

The start point and end point of autonomous breathing loop are configurable. The loop starting point could be selected among T0~T3, which is set by bits LB[1:0] in register PATxT2 (x=0~2, page0, address=0x38, 0x3C, 0x40). The end point of the loop can only be selected between the end of T0 and the end of T2, which is determined by bits LE[1:0] in register PATxT2 (x=0~2). The repeat times are determined by the end point defined. If bits LE[1:0] are not "00", the end point of breathing loop is the end of T0, and the loop counter increment by 1 at the end of T0. If bits LE[1:0] are "00", the loop end point is the end of T2, and the loop counter increment by 1 at the end of T2.

The repeat times are decided by bits LT[11:8] in register PATxT2x (x=0~2) and register PATxT3.LT[7:0] (x=0~2, page0, address=0x39, 0x3D, 0x41). When setting LT[11:0] to "0", the breathing pattern will run unlimited times. After the breathing pattern is over, the status bit PATFLG in register PATxCFG (x=0~2) will be set to "1", and PATFLG will be cleared to "1" after reading out through I<sup>2</sup>C bus. Once breathing loop start again or pattern controller switches to manual mode by setting PATMD bit to "0", the PATFLG will also be cleared.

When bit RUNx in register PATGO (x=0~2, page0, address=0x45) is set to "1", breathing pattern x is started. The full process of the autonomous breathing is as follows:

- Set GCC, SL and PWMxH/L parameter.
- Set Page 3 (PAT choice registers) to select the pattern of LEDs.
- Configure PATxT0, PATxT1, PATxT2, PATxT3 (x=0~2) to control the breath time, start/stop point, and repeat times.
- Set PATEN=1 to enable breathing pattern mode.
- Set PATMD=1 and RAMPE=1 to select auto breathing mode and enable breathing ramp (x=0~2).
- Set LOGEN to select the breathing in log curve mode or linear mode (x=0~2).
- Set RUNx=1 to start the breath pattern x (x=0~2).

### MANUAL CONTROL MODE

If bit PATMD is set to "0", manual control mode is selected. In manual control mode, user could set the bit SWITCH of register PATxCFG (x=0~2) to control the output of pattern controller. When SWITCH is "1", the output of pattern controller is decided by register PWMxH (x=0~2). When bit SWITCH is set to "0", the output is the decided by register PWMxL (x=0~2).

If bit RAMPE in register PATxCFG (x=0~2) is set to "1", the smooth ramp up/down will be enabled. At the same time, if SWITCH changes from "0" to "1", the output will be ramp up to PWMxH (x=0~2) smoothly. Similarly, if SWITCH changes from "1" to "0", the output of the pattern controller will ramp down to PWMxL (x=0~2) smoothly. It's also support the logarithmic mode ramp.

However, if RAMPE is set to "0", the output of the pattern controller will change to PWMxH or PWMxL(x=0~2) directly with no ramp as the SWITCH changes.

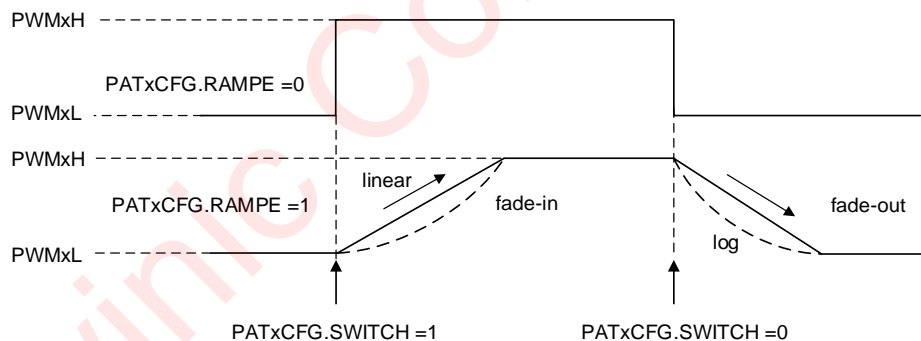

Figure 25 Manual Control Mode

### MULTIPLE DEVICE SYNCHRONIZATION

AW20198 supports multiple device synchronization to drive more than 198 LEDs by cascade of multiple devices. In this application, all devices share a common clock, one device works as a master to output common clock on pin SYNC, and other devices work as slave to use external input clock from pin SYNC. Bit CLKOE and CLKSEL in Register SSCR (page0, address=0x28) select the clock input or output on pin SYNC.

CLKOE	CLKSEL	Device Clock Selection
0	0	Use Internal clock and pin SYNC is high-Z
1	0	Master, use internal clock and output it on pin SYNC
0	1	Slave, use external clock from pin SYNC
1	1	Forbidden

## REGISTER CONFIGURATION

### REGISTER CONTROL

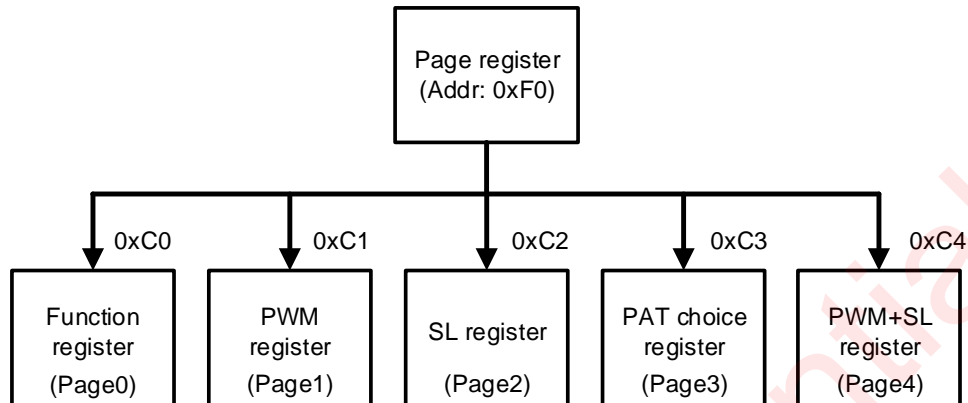

Figure 26 Register Control

Page register (address=0xF0) can select page from page0 to page4. User can choose page0~page4 by writing 0xC0~0xC4 to the page register in any page. The page0 is activated by default. The page4 is a virtual page that can configure PWM and SL in the same time, and the address auto-increases by one after the PWM and SL data are written. The page4 only supports writing, and is available when register MIXCR.PAGE4EN (page0, address=0x46) is set to "1".

### REGISTER LIST

#### Page0: Function Register List

ADDR	NAME	R/W	Bit7	Bit6	Bit5	Bit4	Bit3	Bit2	Bit1	Bit0	Default
0x00	GCR	R/W	SWSEL				LGC	OSDE		CHIPEN	0xB0
0x01	GCCR	R/W	GCC								0x00
0x02	DGCR	R/W	PUMD	CSPUR			PDMD	SWPDR			0x44
0x03 ~ 0x23	OSR0 ~ OSR32	R	-		LED0~LED197 Open/Short status register					0x00	
0x27	OTCR	R/W	OTFLG	OTPD	OTDIS	TRFLG	TRTH		TROF		0x00
0x28	SSCR	R/W	CLKOE	CLKSEL	-	SSE	SRR		CLT		0x00
0x29	PCCR	R/W	PWMFRQ			-			PSEL		0x00
0x2A	UVCR	R/W	REXT_ST		OCPH	OCPD	PUST	UVFLG	UVPD	UVDIS	0x00
0x2B	SRCR	R/W	-		OTH	STH	-	SRR	SRF		0x02
0x2F	RSTN	R/W	RSTN/ID								0x71
0x30	PWMH0	R/W	PWMH0								0x00
0x31	PWMH1	R/W	PWMH1								0x00
0x32	PWMH2	R/W	PWMH2								0x00
0x33	PWML0	R/W	PWML0								0x00
0x34	PWML1	R/W	PWML1								0x00
0x35	PWML2	R/W	PWML2								0x00

ADDR	NAME	R/W	Bit7	Bit6	Bit5	Bit4	Bit3	Bit2	Bit1	Bit0	Default
0x36	PAT0T0	R/W	T0				T1				0x00
0x37	PAT0T1	R/W	T2				T3				0x00
0x38	PAT0T2	R/W	LE	LB			LT[11:8]				0x00
0x39	PAT0T3	R/W	LT[7:0]								0x00
0x3A	PAT1T0	R/W	T0				T1				0x00
0x3B	PAT1T1	R/W	T2				T3				0x00
0x3C	PAT1T2	R/W	LE	LB			LT[11:8]				0x00
0x3D	PAT1T3	R/W	LT[7:0]								0x00
0x3E	PAT2T0	R/W	T0				T1				0x00
0x3F	PAT2T1	R/W	T2				T3				0x00
0x40	PAT2T2	R/W	LE	LB			LT[11:8]				0x00
0x41	PAT2T3	R/W	LT[7:0]								0x00
0x42	PAT0CFG	R/W	-	PATFLG	LOGEN	SWITH	RAMPE	PATMD	PATEN		0x00
0x43	PAT1CFG	R/W	-	PATFLG	LOGEN	SWITH	RAMPE	PATMD	PATEN		0x00
0x44	PAT2CFG	R/W	-	PATFLG	LOGEN	SWITH	RAMPE	PATMD	PATEN		0x00
0x45	PATGO	R/W	-	PAT2ST	PAT1ST	PAT0ST	-	RUN2	RUN1	RUN0	0x00
0x46	MIXCR	R/W	-				PAGE4EN	LPEN	BCDIS		0x00
0x4D	SDCR		-				SDCR				0x00
0xF0	PAGE	R/W	-				PAGE				0x00

Page1: PWM Register List

ADDR	NAME	R/W	Bit7	Bit6	Bit5	Bit4	Bit3	Bit2	Bit1	Bit0	Default
0x00	PWM0	R/W	PWM0								0x00
0x01	PWM1	R/W	PWM1								0x00
...	...	R/W	...								0x00
0xC5	PWM197	R/W	PWM197								0x00
0xF0	PAGE	R/W	-				PAGE				0x00

Page2: SL Register List

ADDR	NAME	R/W	Bit7	Bit6	Bit5	Bit4	Bit3	Bit2	Bit1	Bit0	Default
0x00	SL0	R/W	SL0								0x00
0x01	SL1	R/W	SL1								0x00
...	...	R/W	...								0x00
0xC5	SL197	R/W	SL197								0x00
0xF0	PAGE	R/W	-				PAGE				0x00

Page3: PAT Choice Register List

ADDR	NAME	R/W	Bit7	Bit6	Bit5	Bit4	Bit3	Bit2	Bit1	Bit0	Default
0x00	PATG0	R/W	-	PAT2		PAT1		PAT0			0x00

ADDR	NAME	R/W	Bit7	Bit6	Bit5	Bit4	Bit3	Bit2	Bit1	Bit0	Default
0x01	PATG1	R/W	-		PAT5		PAT4		PAT3		0x00
...	...	R/W	-		...		...		...		0x00
0x41	PATG65	R/W	-		PAT197		PAT196		PAT195		0x00
0xF0	PAGE	R/W	-				PAGE				0x00

Page4: PWMx+SLx Register List

ADDR	NAME	R/W	Bit15	Bit14	...	Bit8	Bit7	Bit6	...	Bit0	Default
0x00	PWM0+ SL0	W	PWM0				SL0				0x00
0x01	PWM1+ SL1	W	PWM1				SL1				0x00
...	...	W	...				...				0x00
0xC5	PWM197+ SL197	W	PWM197				SL197				0x00
0xF0	PAGE	W	-							PAGE	0x00

## REGISTER DETAILED DESCRIPTION

### GCR: Global Control Register (Page 0: Address 0x00)

Bit	Symbol	R/W	Description	Default
7:4	SWSEL	R/W	Active the SW number select 0000: SW1 active SW2~SW11 not active 0001: SW1~SW2 active SW3~SW11 not active 0010: SW1~SW3 active SW4~SW11 not active 0011: SW1~SW4 active SW5~SW11 not active 0100: SW1~SW5 active SW6~SW11 not active 0101: SW1~SW6 active SW7~SW11 not active 0110: SW1~SW7 active SW8~SW11 not active 0111: SW1~SW8 active SW9~SW11 not active 1000: SW1~SW9 active SW10~SW11 not active 1001: SW1~SW10 active SW11 not active 1010~1111: SW1~SW11 active	1011
3	LGC	R/W	Logic level select 0: 1.4/0.4V 1: 2.4/0.6V	0
2:1	OSDE	R/W	Open/short detect enable 0x: Detect disable 10: Short detect 11: Open detect	00
0	CHIPEN	R/W	Chip enable 0: Disable 1: Enable	0

**GCCR: Global Current Control Register (Page 0: Address 0x01)**

Bit	Symbol	R/W	Description	Default
7:0	GCC	R/W	Global current control	0x00

**DGCR: De-ghost Control Register (Page 0: Address 0x02)**

Bit	Symbol	R/W	Description	Default
7	PUMD	R/W	Pull up mode select 0: Only in CSx off time (x=1~18) 1: All the time	0
6:4	CSPUR	R/W	CS pull up resistance select 000: Disable pull up resistance 001: 0.5kΩ 010: 1kΩ 011: 2 kΩ 100: 4 kΩ 101: 8 kΩ 110: 16 kΩ 111: 32 kΩ	100
3	PDMD	R/W	Pull down mode select 0: Only in SWx off time (x=1~11) 1: All the time	0
2:0	SWPDR	R/W	SW pull down resistance select 000: Disable pull down resistance 001: 0.25kΩ 010: 0.5kΩ 011: 1 kΩ 100: 2 kΩ 101: 4 kΩ 110: 8 kΩ 111: 16 kΩ	100

**OSR0~OSR32: Open/Short Status Register (Page 0: Address 0x03~0x23)**

Bit	Symbol	R/W	Description	Default
7:6	RESERVED	R	Reserved	00
5:0	OSR	R	Open/short status of LED0~LED197 0: Open/short not happen 1: Open/short happen	000000

**OTCR: Over Temperature Control Register (Page 0: Address 0x27)**

Bit	Symbol	R/W	Description	Default
7	OTFLG	R	Over temperature flag 0: Over-temperature not happen 1: Over-temperature happen	0
6	OTPD	R/W	Over-temperature(OT) protect disable 0: OT protect enable, when OT event occurs, device will clear GCR.CHIPEN to 0. 1: OT protect disable	0
5	OTDIS	R/W	Over-temperature detect disable 0: OT detect enable, when OT event occurs, OTCR.OTFLAG will be set. 1: OT detect disable	0
4	TRFLAG	R	Thermal roll off status 0: Roll off not happen 1: Roll off happen	0
3:2	TRTH	R/W	Thermal roll threshold 00: 140°C 01: 120°C 10: 100°C 11: 90°C	00
1:0	TROF	R/W	Thermal roll off percentage of I <sub>OUT</sub> 00: 100% 01: 75% 10: 55% 11: 30%	00

**SSCR: Spread Spectrum Control Register (Page 0: Address 0x28)**

Bit	Symbol	R/W	Description	Default
7	CLKOE	R/W	Clock output enable 0: Disable 1: Enable	0
6	CLKSEL	R/W	0: Use internal 16MHz OSC clock 1: Use clock input from pin SYNC	0
5	RESERVED	R	Reserved	0
4	SSE	R/W	Spread spectrum enable 0: Disable 1: Enable	0
3:2	SSR	R/W	Spread spectrum range 00: ±5% 01: ±15% 10: ±25% 11: ±35%	00

Bit	Symbol	R/W	Description	Default
1:0	CLT	R/W	Spread spectrum cycle time 00: 1980μs 01: 1200μs 10: 820μs 11: 660μs	00

**PCCR: PWM Clock Control Register (Page 0: Address 0x29)**

Bit	Symbol	R/W	Description	Default
7:5	PWMFRQ	R/W	PWM frequency selection 000: 62.5kHz 001: 32.25kHz 010: 15.6kHz 011: 7.8kHz 100: 3.9kHz 101: 1.95kHz 110: 977Hz 111: 488Hz	000
4:2	RESERVED	R	Reserved	000
1:0	PSEL	R/W	PWM phase selection 00: Phase delay mode 01: Phase inverting mode 1x: Three-phase mode	00

**UVCR: UVLO Control Register (Page 0: Address 0x2A)**

Bit	Symbol	R/W	Description	Default
7:6	REXT_ST	R	REXT status 00: Normal 10: REXT is open 01: REXT is short or OCP 11: Not defined	00
5	OCPH	R/W	OCP threshold 0: 120mA 1: 75mA	0
4	OCPD	R/W	OCP disable 0: Enable OCP 1: Disable OCP	0
3	PUST	R	Power-up reset status 0: Power-up reset not happen 1: Power-up reset happen	0
2	UVFLG	R	UVLO status 0: UVLO not happen 1: UVLO happen	0

Bit	Symbol	R/W	Description	Default
1	UVPD	R/W	UVLO protect disable 0: UVLO protect enable, when under-voltage event occurs, device will clear GCR.CHIPEN to 0. 1: UVLO protect disable	0
0	UVDIS	R/W	UVLO detect disable 0: UVLO detect enable, when under-voltage event occurs, UVCR.UVFLG will be set. 1: UVLO detect disable	0

**SRCR: Open/Short Control Register (Page 0: Address 0x2B)**

Bit	Symbol	R/W	Description	Default
7:6	RESERVED	R	Reserved	00
5	OTH	R/W	Open threshold 0: 0.1V 1: 0.2V	0
4	STH	R/W	Short threshold 0: PVCC-1.5V 1: PVCC-0.8V	0
3	RESERVED	R	Reserved	0
2	SRR	R/W	Slew rate control for LED output rising time 0: 1ns 1: 6ns	0
1:0	SRF	R/W	Slew rate control for LED output falling time 00: 1ns 01: 3ns 10: 6ns 11:10ns	10

**RSTN: Reset Register (Page 0: Address 0x2F)**

Bit	Symbol	R/W	Description	Default
7:0	RSTN	R/W	Write 0xAE to the register will reset all registers to their default value. The chip ID will be read out from the register.	0x71

**PWMH0~PWMH2: Maximum Brightness for Auto Breath (Page 0: Address 0x30~0x32)**

Bit	Symbol	R/W	Description	Default
7:0	PWMH	R/W	Maximum brightness configure for auto breath.	0x00

**PWML0~PWML2: Minimum Brightness for Auto Breath (Page 0: Address 0x33~0x35)**

Bit	Symbol	R/W	Description	Default
7:0	PWML	R/W	Minimum brightness configure for auto breath.	0x00

**PAT0T0~PAT2T0: Pattern Timer 0 (Page 0: Address 0x36 0x3A 0x3E)**

Bit	Symbol	R/W	Description	Default	
7:4	T0	R/W	Ramp rise time	0000	
			T0 Time		T0 Time
			0000 0s		1000 2.1s
			0001 0.13s		1001 2.6s
			0010 0.26s		1010 3.1s
			0011 0.38s		1011 4.2s
			0100 0.51s		1100 5.2s
			0101 0.77s		1101 6.2s
			0110 1.04s		1110 7.3s
0111 1.6s	1111 8.3s				
3:0	T1	R/W	Hold on time	0000	
			T1 Time		T1 Time
			0000 0.04s		1000 2.1s
			0001 0.13s		1001 2.6s
			0010 0.26s		1010 3.1s
			0011 0.38s		1011 4.2s
			0100 0.51s		1100 5.2s
			0101 0.77s		1101 6.2s
			0110 1.04s		1110 7.3s
0111 1.6s	1111 8.3s				

**PAT0T1~PAT2T1: Pattern Timer 1 (Page 0: Address 0x37 0x3B 0x3F)**

Bit	Symbol	R/W	Description	Default	
7:4	T2	R/W	Ramp fall time	0000	
			T2 Time		T2 Time
			0000 0s		1000 2.1s
			0001 0.13s		1001 2.6s
			0010 0.26s		1010 3.1s
			0011 0.38s		1011 4.2s
			0100 0.51s		1100 5.2s
			0101 0.77s		1101 6.2s
			0110 1.04s		1110 7.3s
0111 1.6s	1111 8.3s				
3:0	T3	R/W	Hold off time	0000	
			T3 Time		T3 Time
			0000 0.04s		1000 2.1s
			0001 0.13s		1001 2.6s
			0010 0.26s		1010 3.1s
			0011 0.38s		1011 4.2s
			0100 0.51s		1100 5.2s
			0101 0.77s		1101 6.2s
			0110 1.04s		1110 7.3s
0111 1.6s	1111 8.3s				

**PAT0T2~PAT2T2: Pattern Control Register 1 (Page 0: Address 0x38 0x3C 0x40)**

Bit	Symbol	R/W	Description	Default
7:6	LE	R/W	End point of the auto-breath loop pattern 00: Pattern finally stop at OFF state Other: Pattern finally stop at ON state	00
5:4	LB	R/W	Start point of the auto-breath loop pattern 00: Pattern start from RISE state 01: Pattern start from ON state 10: Pattern start from FALL state 11: Pattern start from OFF state	00
3:0	LT[11:8]	R/W	4 MSB of auto-breath loop times	0000

**PAT0T3~PAT2T3: Pattern Control Register 2 (Page 0: Address 0x39 0x3D 0x41)**

Bit	Symbol	R/W	Description	Default
7:0	LT[7:0]	R/W	8 LSB of auto-breath loop times Note: when LT[11:0]=0, the pattern will run forever. In this case, you can switch auto-breath mode to manual mode and then turn the pattern off.	0x00

**PAT0CFG~PAT2CFG: Configure Register (Page 0: Address 0x42~0x44)**

Bit	Symbol	R/W	Description	Default
7:6	RESERVED	R	Reserved	00
5	PATFLG	R	Auto breath pattern loop end flag 0: Loop is not over 1: Loop is over	0
4	LOGEN	R/W	Log curve output enable 0: Disable 1: Enable	0
3	SWITCH	R/W	Switch on or off at manual mode. 0: LED off 1: LED on	0
2	RAMPE	R/W	PAT ramp enable 0: Ramp disable 1: Ramp enable	0
1	PATMD	R/W	Breath pattern control mode selection 0: Manual mode 1: Auto breath pattern mode	0
0	PATEN	R/W	Auto breath pattern controller enable 0: Disable 1: Enable	0

**PATGO: Start Control Register (Page 0: Address 0x45)**

Bit	Symbol	R/W	Description	Default
7	RESERVED	R	Reserved	0
6	PAT2ST	R	Auto breath pattern 2 status 0: Pattern is stop 1: Pattern is running	0
5	PAT1ST	R	Auto breath pattern 1 status 0: Pattern is stop 1: Pattern is running	0

Bit	Symbol	R/W	Description	Default
4	PAT0ST	R	Auto breath pattern 0 status 0: Pattern is stop 1: Pattern is running	0
3	RESERVED	R	Reserved	0
2	RUN2	R/W	Auto breath pattern 2 run control Write "1" to run auto breath pattern Note: You shall write "0" and then write "1" to this bit to restart a new auto breath pattern.	0
1	RUN1	R/W	Auto breath pattern 1 run control Write "1" to run auto breath pattern Note: You shall write "0" and then write "1" to this bit to restart a new auto breath pattern.	0
0	RUN0	R/W	Auto breath pattern 0 run control Write "1" to run auto breath pattern Note: You shall write "0" and then write "1" to this bit to restart a new auto breath pattern.	0

**MIXCR: Mix Function Control Register (Page 0: Address 0x46)**

Bit	Symbol	R/W	Description	Default
7:3	RESERVED	R	Reserved	00000
2	PAGE4EN	R/W	Page 4 enable 0: Disable 1: Enable	0
1	LPEN	R/W	Low-power mode enable 0: Disable 1: Enable	0
0	BCDIS	R/W	Broadcast disable 0: Enable 1: Disable	0

**SDCR: SW Drive Capability Register (Page 0: Address 0x4D)**

Bit	Symbol	R/W	Description	Default
7:3	RESERVED	R	Reserved	00000
2:0	SDCR	R/W	Select the SW drive capability 000: 0.99A                      100: 1.61A 001: 1.08A                      101: 1.72A 010: 1.19A                      110: 1.85A 011: 1.32A                      111: 2.00A	000

**PWMx (x=0~197): PWM Configure Register (Page 1: Address 0x00~0xC5)**

Bit	Symbol	R/W	Description	Default
7:0	PWMx	R/W	PWM modulated	0x00

**SLx (x=0~197): SL Configure Register (Page 2: Address 0x00~0xC5)**

Bit	Symbol	R/W	Description	Default
7:0	SLx	R/W	Control the constant current	0x00

**PATGx (x=0~65): PAT Choice Register (Page 3: Address 0x00~0x41)**

Bit	Symbol	R/W	Description	Default
7:6	RESERVED	R	Reserved	00
5:4	PAT3x+2	R/W	Control the patterns of LED 3x+2: 00: PWM parameter comes from PWM register 01: PWM parameter comes from pattern controller 0 10: PWM parameter comes from pattern controller 1 11: PWM parameter comes from pattern controller 2	00
3:2	PAT3x+1	R/W	Control the patterns of LED 3x+1: 00: PWM parameter comes from PWM register 01: PWM parameter comes from pattern controller 0 10: PWM parameter comes from pattern controller 1 11: PWM parameter comes from pattern controller 2	00
1:0	PAT3x	R/W	Control the patterns of LED 3x: 00: PWM parameter comes from PWM register 01: PWM parameter comes from pattern controller 0 10: PWM parameter comes from pattern controller 1 11: PWM parameter comes from pattern controller 2	00

**PWMx+SLx (x=0~197): PWM and SL Configure Register (Page 4: Address 0x00~0xC5)**

Bit	Symbol	R/W	Description	Default
15:8	PWMx	W	PWM modulated	0x00
7:0	SLx	W	Control the constant current	0x00

## APPLICATION INFORMATION

PVCC and VCC should use same power supply to avoid the additional ISD, such as PVCC=VCC=5V and VIO=3.3V.

If the equipment has antenna, the IC should be far away from the antenna in order to avoid the EMI.

### R<sub>EXT</sub>

The selection of R<sub>EXT</sub> determined the maximum LED0~LED197 current I<sub>max</sub> as described in below formula (1).

$$I_{max} = \frac{K}{R_{EXT}} \quad (1)$$

When R<sub>EXT</sub> = 10KΩ, I<sub>max</sub> = 40mA, I<sub>switch</sub> = 720mA, SDCR[2:0] = 000 (page0, address = 0x4D)

When R<sub>EXT</sub> = 5KΩ, I<sub>max</sub> = 80mA, I<sub>switch</sub> = 1.44A, SDCR[2:0] = 111 (page0, address = 0x4D).

## PCB LAYOUT CONSIDERATION

AW20198 is an 18x11 matrix LED driver programmed via an I<sup>2</sup>C compatible interface. When all LEDs are operating, the device power dissipation is large. To obtain the good thermal performance and avoid thermal shutdown, PCB layout should be considered carefully. Here are some guidelines:

1. The C<sub>1</sub>、C<sub>2</sub>、C<sub>3</sub>、C<sub>4</sub>、C<sub>5</sub> should be placed as close to the chip as possible.
2. The R<sub>3</sub> should be placed as close to the chip as possible.
3. The Thermal PAD must be well connecting to the GND of the PCB, and add as many thermal via as possible beneath the thermal PAD on the PCB for the heat conductivity of the device and PCB.

## TAPE AND REEL INFORMATION

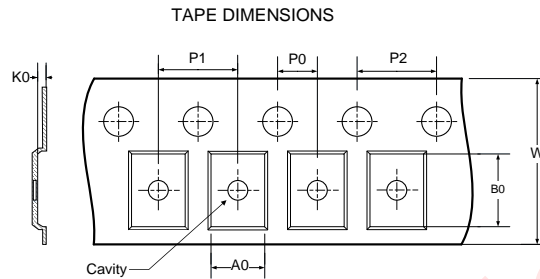
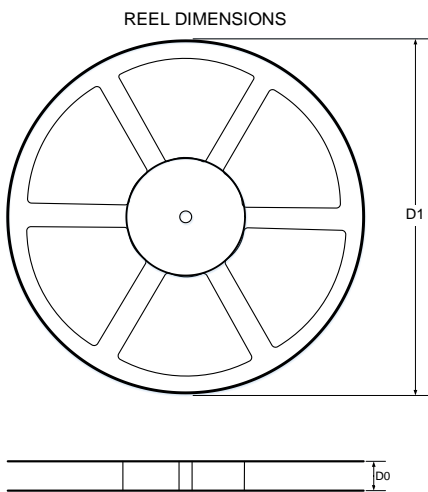

A0: Dimension designed to accommodate the component width  
 B0: Dimension designed to accommodate the component length  
 K0: Dimension designed to accommodate the component thickness  
 W: Overall width of the carrier tape  
 P0: Pitch between successive cavity centers and sprocket hole  
 P1: Pitch between successive cavity centers  
 P2: Pitch between sprocket hole  
 D1: Reel Diameter  
 D0: Reel Width

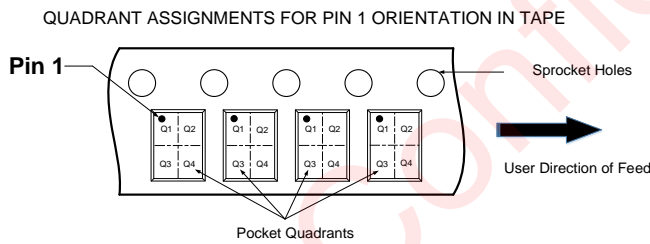

### DIMENSIONS AND PIN1 ORIENTATION

D1 (mm)	D0 (mm)	A0 (mm)	B0 (mm)	K0 (mm)	P0 (mm)	P1 (mm)	P2 (mm)	W (mm)	Pin1 Quadrant
330	12.4	5.25	5.25	0.8	2	8	4	12	Q1

All dimensions are nominal

PACKAGE DESCRIPTION

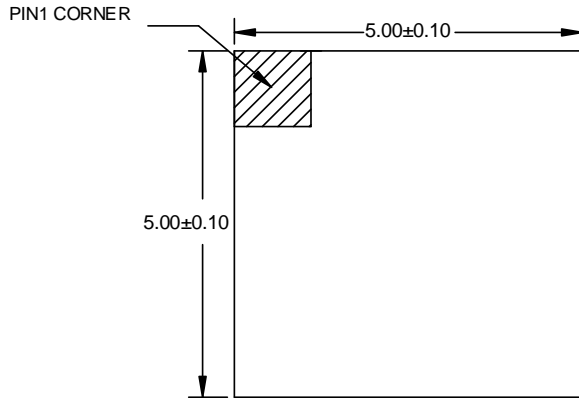

Top View

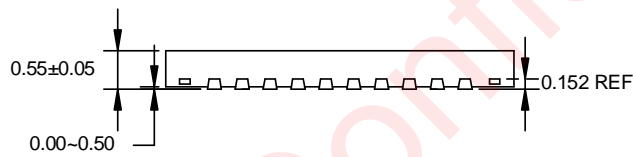

Side View

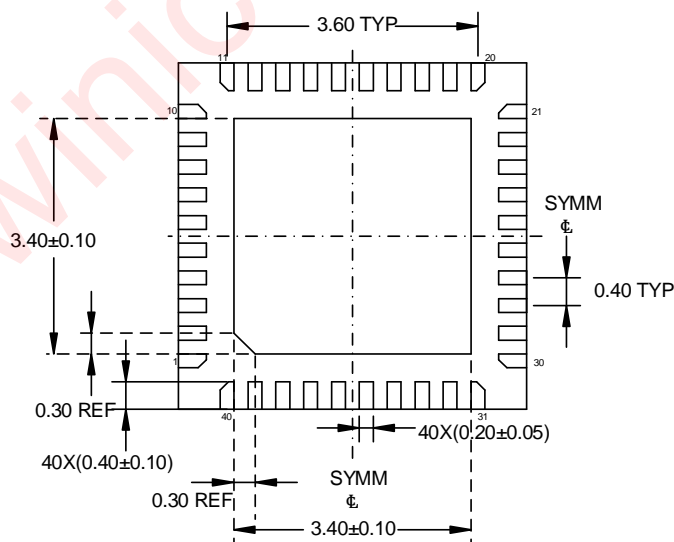

Bottom View

Unit : mm

LAND PATTERN DATA

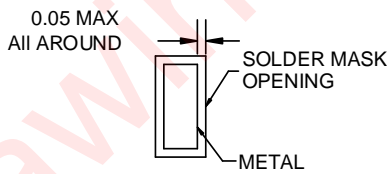
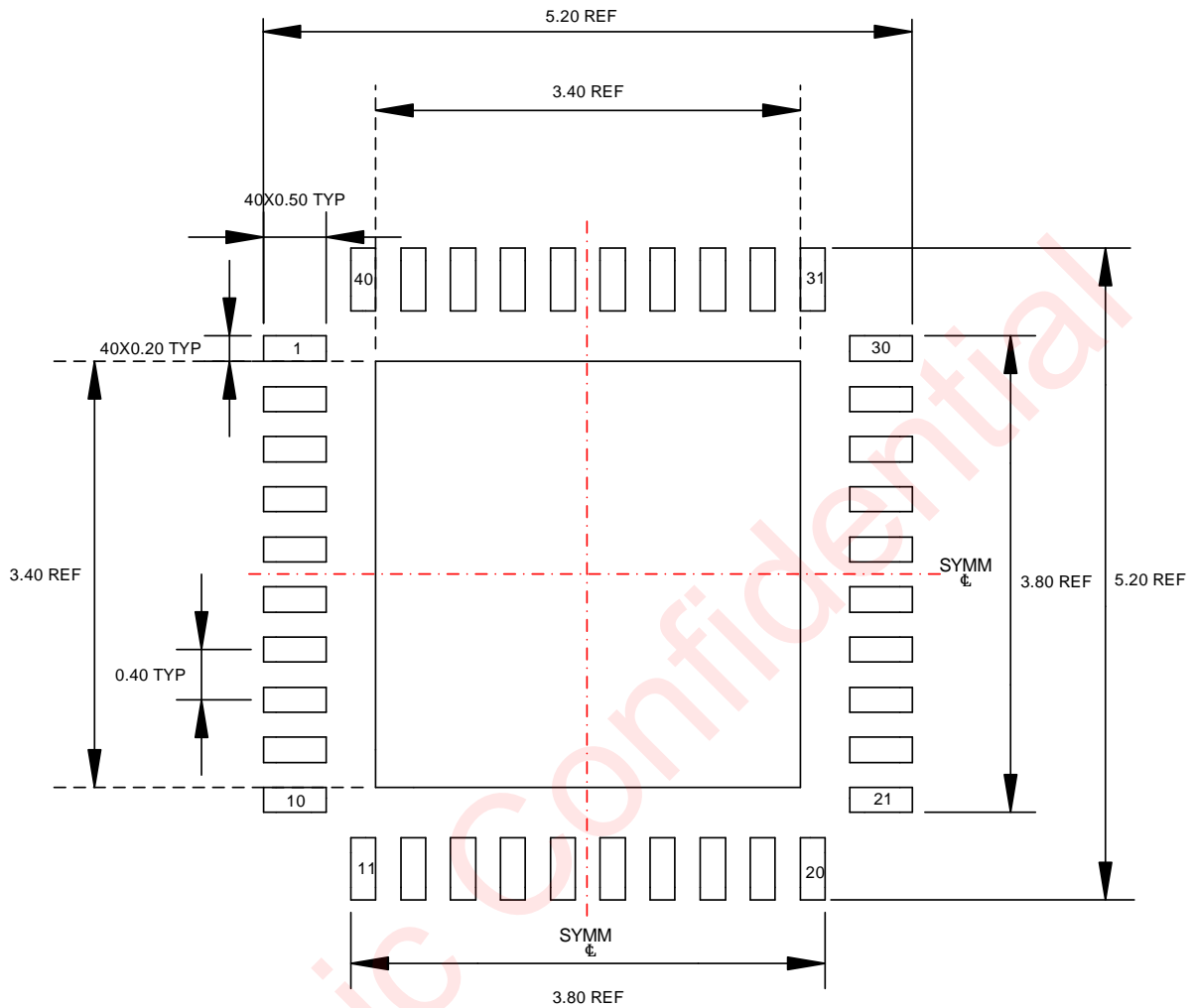

NON SOLDER MASK DEFINED

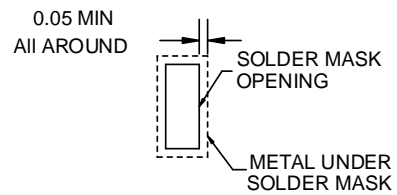

SOLDER MASK DEFINED

Unit : mm

## REVISION HISTORY

Version	Date	Change Record
V1.0	Apr. 2020	Officially released
V1.1	May. 2020	Update the ESD report -- page6 Modify the CHIP ID -- page23
V1.2	Jun. 2020	Add the EMI reduction description -- page20 Add optional SW drive capability register description -- page33 Add application information description -- page35
V1.3	Oct. 2020	Add the Notes in application -- page35

awinic Confidential

## DISCLAIMER

All trademarks are the property of their respective owners. Information in this document is believed to be accurate and reliable. However, Shanghai AWINIC Technology Co., Ltd (AWINIC Technology) does not give any representations or warranties, expressed or implied, as to the accuracy or completeness of such information and shall have no liability for the consequences of use of such information.

AWINIC Technology reserves the right to make changes to information published in this document, including without limitation specifications and product descriptions, at any time and without notice. Customers shall obtain the latest relevant information before placing orders and shall verify that such information is current and complete. This document supersedes and replaces all information supplied prior to the publication hereof.

AWINIC Technology products are not designed, authorized or warranted to be suitable for use in medical, military, aircraft, space or life support equipment, nor in applications where failure or malfunction of an AWINIC Technology product can reasonably be expected to result in personal injury, death or severe property or environmental damage. AWINIC Technology accepts no liability for inclusion and/or use of AWINIC Technology products in such equipment or applications and therefore such inclusion and/or use is at the customer's own risk.

Applications that are described herein for any of these products are for illustrative purposes only. AWINIC Technology makes no representation or warranty that such applications will be suitable for the specified use without further testing or modification.

All products are sold subject to the general terms and conditions of commercial sale supplied at the time of order acknowledgement.

Nothing in this document may be interpreted or construed as an offer to sell products that is open for acceptance or the grant, conveyance or implication of any license under any copyrights, patents or other industrial or intellectual property rights.

Reproduction of AWINIC information in AWINIC data books or data sheets is permissible only if reproduction is without alteration and is accompanied by all associated warranties, conditions, limitations, and notices. AWINIC is not responsible or liable for such altered documentation. Information of third parties may be subject to additional restrictions.

Resale of AWINIC components or services with statements different from or beyond the parameters stated by AWINIC for that component or service voids all express and any implied warranties for the associated AWINIC component or service and is an unfair and deceptive business practice. AWINIC is not responsible or liable for any such statements.