



浙江汇隆晶片技术有限公司
Zhejiang Huilong Crystals Technology Co.,Ltd

SPECIFICATION FOR APPROVAL

CUSTOMER _____



NOMINAL FREQUENCY 32.000000 MHz

HOLDER TYPE 3225

SPEC. NO. (P/N) HL32000009

CUSTOMER P/N _____

ISSUE DATE Jul.30,2024

APPROVED	PREPARED	QA
		
APPROVED BY CUSTOMER:		AVL Status
<p>Please return one copy with approval toHLC</p>		

浙江省金华市经济开发区工业园区秋涛北街399号
 No.399 Qiutao North Str.,Industrial Area,Economic
 Development Zone,Jinhua,Zhejiang,China
 TEL: 0086-579-82273331
 FAX: 0086-579-82273198
<http://www.cn-hlc.com>



RoHS Compliant (Pb- Free)



TYPE HL SEAM SEALED X'TAL

ELECTRICAL SPECIFICATIONS

HLC Parts Number : HL32000009

Item	Symbol	Specifications				Notes
		Min	Type	Max	Units	
Nominal frequency	FO	32.000000			MHz	
Mode of Oscillation	OT	Fundamental				
Load Capacitance	CL	10			pF	
Frequency Tolerance	FT	± 10			ppm	at 25°C ± 3°C
Frequency Stability		± 30			ppm	with working temperature Reference to 25°C frequency
Working temperature range	TR	-40~85			°C	
Drive Level	DL	100			μW	
Series Resonant Resistance RR	CI/RR	40			Ω	Max.
Insulation Resistance	IR	>500			MΩ	
Shunt Capacitance C0	C0	3			pF	Max.
Aging		± 3			ppm/yr.	
Storage temperature range		-55 ~ 125			°C	

Zhejiang Huilong Crystals Technology Co.,Ltd



TYPE HL SEAM SEALED X'TAL

RELIABILITY SPECIFICATIONS

NO.	TEST ITEM	TEST METHODS												
1	DROP TEST	Device are dropped from a height of 150 cm onto 2 mm thickness stainless plate executing 3 times of random drops.												
2	MECHANICAL SHOCK	Device are shocked to half sine wave (1000 G) three mutually perpendicular axes each 3 times.												
3	VIBRATION	<table border="0"> <tr> <td>Frequency range</td> <td>10 ~ 2000 Hz</td> </tr> <tr> <td>Amplitude</td> <td>1.5 mm</td> </tr> <tr> <td>Sweep Time</td> <td>20 minute</td> </tr> <tr> <td>Test Time</td> <td>2 hours</td> </tr> </table>	Frequency range	10 ~ 2000 Hz	Amplitude	1.5 mm	Sweep Time	20 minute	Test Time	2 hours				
Frequency range	10 ~ 2000 Hz													
Amplitude	1.5 mm													
Sweep Time	20 minute													
Test Time	2 hours													
4	SOLDERABILITY	<table border="0"> <tr> <td>MIL - STD - 20E Method 208C</td> <td></td> </tr> <tr> <td>Temperature</td> <td>245 °C ± 5 °C</td> </tr> <tr> <td>Material</td> <td>H63A (Silver 2 ~ 3 %)</td> </tr> <tr> <td>Immersion depth</td> <td>0.5 mm minimum</td> </tr> <tr> <td>Immersion time</td> <td>3 ± 0.5 seconds</td> </tr> <tr> <td>Flux</td> <td>Rosin resin methyl alcohol solvent (1 : 4)</td> </tr> </table>	MIL - STD - 20E Method 208C		Temperature	245 °C ± 5 °C	Material	H63A (Silver 2 ~ 3 %)	Immersion depth	0.5 mm minimum	Immersion time	3 ± 0.5 seconds	Flux	Rosin resin methyl alcohol solvent (1 : 4)
MIL - STD - 20E Method 208C														
Temperature	245 °C ± 5 °C													
Material	H63A (Silver 2 ~ 3 %)													
Immersion depth	0.5 mm minimum													
Immersion time	3 ± 0.5 seconds													
Flux	Rosin resin methyl alcohol solvent (1 : 4)													
5	RESISTANCE TO SOLDERING HEAT	MIL - SLD -202, Method 210, Condition I or J 10 sec immersion into 260 ± 5 °C solder pot, above 180 °C is 90 ~ 120 sec.												
6	LOW TEMP. STORAGE	Leave at - 40 °C ± 2 °C for 16 hours												
7	HIGH TEMP. STORAGE	Leave at 125 °C ± 3 °C for 72 hours												
8	THERMAL SHOCK	Total 100 cycles of the following temperature cycle												

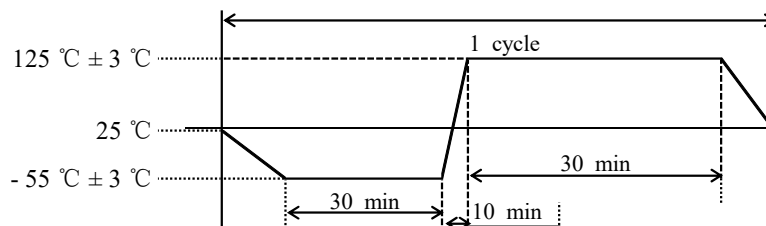

Zhejiang Huilong Crystals Technology Co.,Ltd

DIMENSIONS

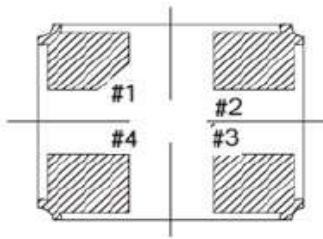
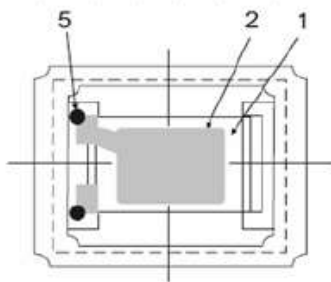
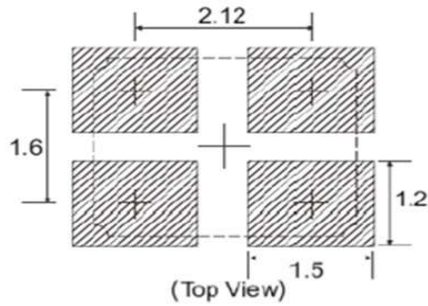
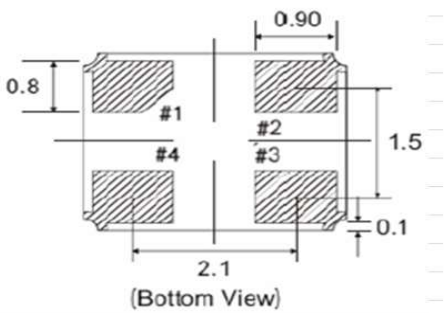
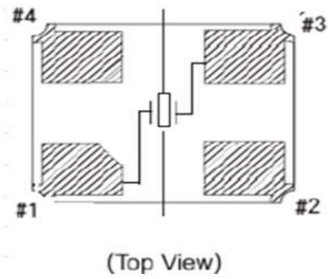
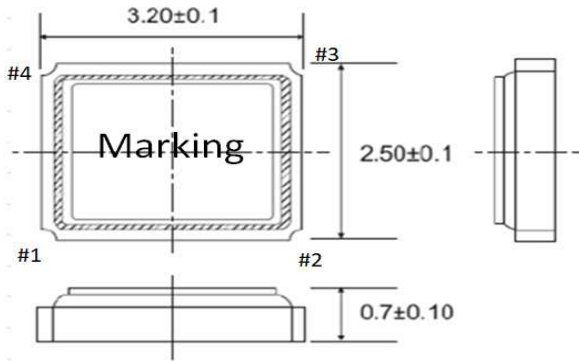

1	Quartz Blank
2	Electrode
3	Lid
4	Base
5	Conductive adhesive

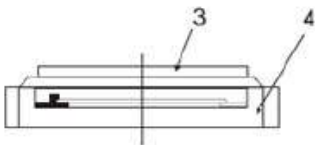

Zhejiang Huilong Crystals Technology Co.,Ltd



TYPE HL SEAM SEALED X'TAL

SUGGESTED IR REFLOW PROFILE

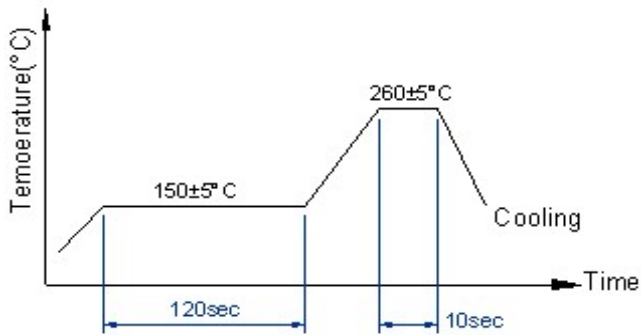

Total Time: 200 Sec.Max
Solder melting point : 185°C

PACKING

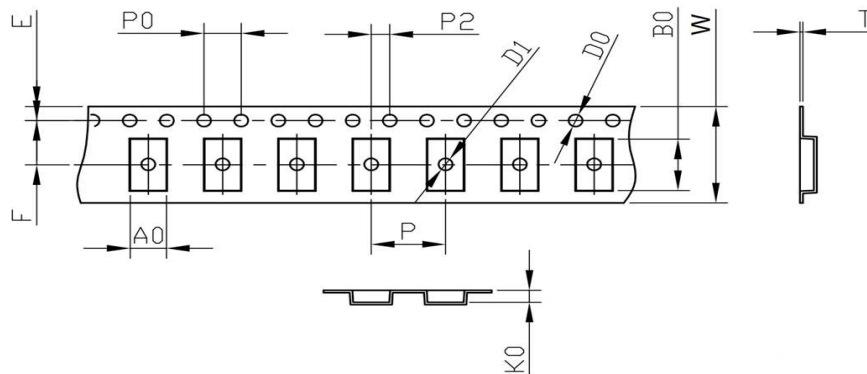

	W	A ₀	B ₀	K ₀	E	F	P	P ₀	P ₂	D ₀	D ₁	T
3225	8.0±0.3	2.70±0.1	3.40±0.1	0.80±0.1	1.75±0.1	3.5±0.1	4.0±0.1	4.0±0.1	2.0±0.1	1.55±0.05	1.0±0.1	0.25±0.05

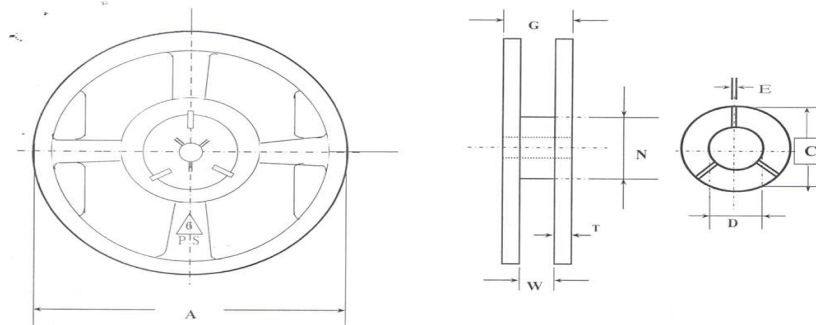

	A	W	T	N	C	D	E	G
3225	178±2.0	9.5±0.5	1.4±0.2	60.2±0.5	20.2±1.0	13.2±0.5	2.5±0.5	12±1.4

- 230mm minimum leafer which consist of carrier and/or tape followed by a minimum of 160mm of empty carrier tape sealed with cover tape.
- 160mm minimum trailer of empty carrier tape sealed with cover tape.

Zhejiang Huilong Crystals Technology Co.,Ltd

PACKING

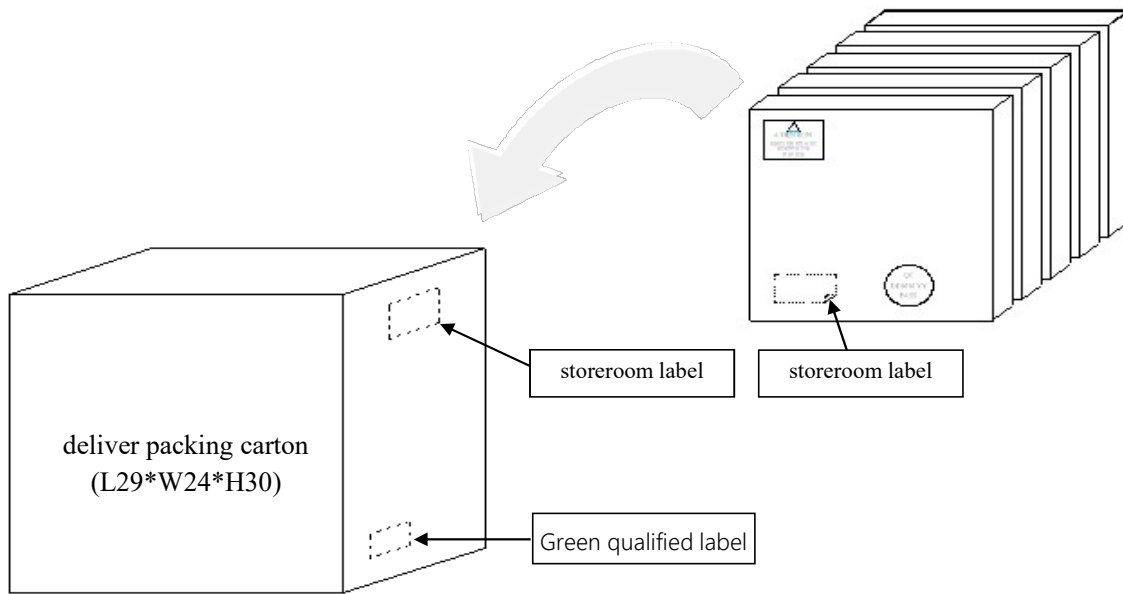
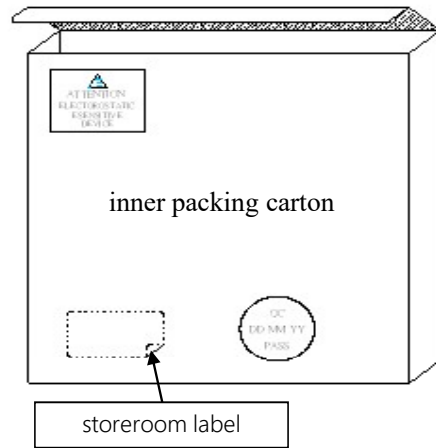
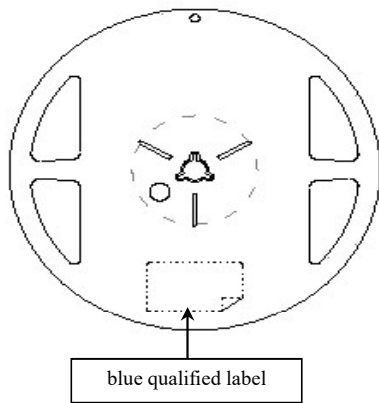
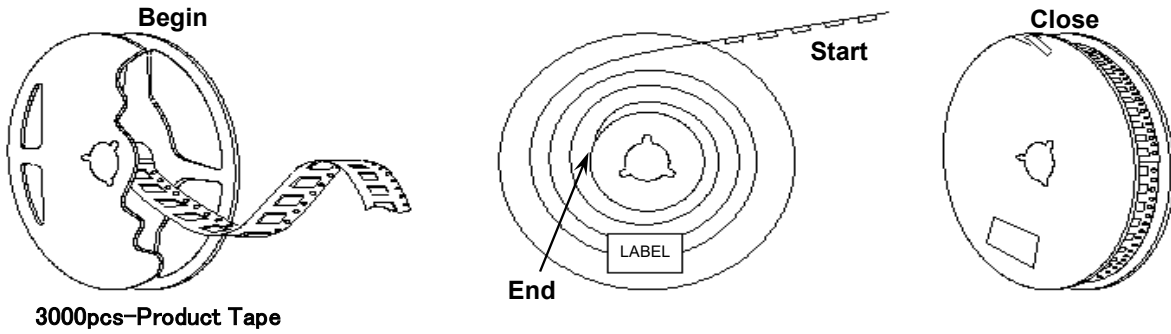

Zhejiang Huilong Crystals Technology Co.,Ltd