

1 FEATURES

- 3.0~5.5V Operation
- Extended ESD Protection for RS-485/RS-422 I/O Pins ±15kV Human Body Model
- True Fail-Safe Receiver While Maintaining EIA/TIA-485 Compatibility
- Guaranteed 1Mbps Data Rate
- Low-Current Shutdown Mode
- Allow Up to 256 Transceivers on the Bus
- Available in Industry-Standard SOP8 Package

2 APPLICATIONS

- RS-485 Communications
- Level Translators
- Motor Controller
- Industrial Control Local Area Networks
- Energy Meter Networks
- Power Inverters
- Building Automation Networks
- Telecommunications Equipment

3 GENERAL DESCRIPTION

The YD3082E is ± 15kV electrostatic discharge (ESD) protected, high-speed transceiver for RS-485 communication that contain one driver and one receiver. The device features fail-safe circuitry, which guarantees a logic-high receiver output when the receiver inputs are open or shorted. This means that the receiver output will be logic-high even if all transmitters on a terminated bus are disabled. The YD3082E driver slew rate is not limited, making transmit speeds up to 1Mbps possible. All transmitter outputs and receiver inputs are protected to ±15kV using the Human Body Model. The transceiver typically draws 140 micron ampere of supply current when unloaded, or when fully loaded with the driver disabled. This device has a 1/8-unit-load receiver input impedance that allows up to 256 transceivers on the bus. The YD3082E is intended for half-duplex communications.

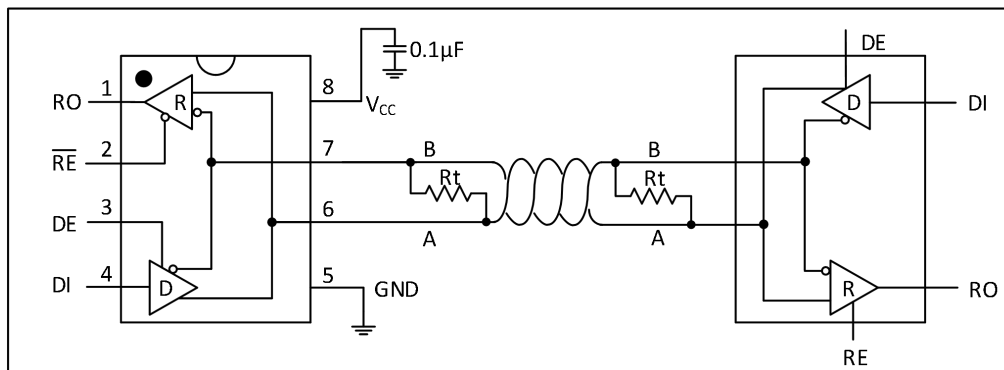

TYPICAL HALF-DUPLEX APPLICATION CIRCUIT

4 PIN CONFIGURATION AND FUNCTIONS

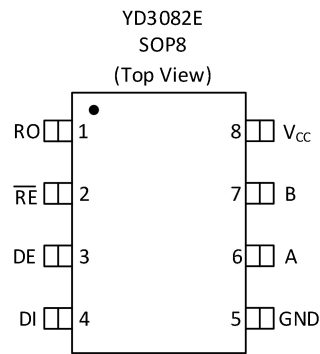

Pin		Description
Name	No.	
RO	1	Receiver Output. When \overline{RE} is low and if $(A-B) \geq -50\text{mV}$, RO is high; if $(A-B) \leq -200\text{mV}$, RO is low.
\overline{RE}	2	Receiver Output Enable. Drive \overline{RE} low to enable the RO; Drive \overline{RE} high to let the RO in high-impedance; Drive \overline{RE} high and DE low to enter low-power shutdown mode.
DE	3	Driver Output Enable. Drive DE high to enable driver outputs; These outputs are high-impedance when DE is low; Drive \overline{RE} high and DE low to enter low-power shutdown mode.
DI	4	Driver Input. With DE high, a low on DI forces non-inverting output low and inverting output high. Similarly, a high on DI forces non-inverting output high and inverting output low.
GND	5	Ground
A	6	Non-inverting Receiver Input and Non-inverting Driver Output
B	7	Inverting Receiver Input and Inverting Driver Output
V _{CC}	8	Positive Supply V _{CC} = 3.0~5.5V. Bypass V _{CC} to GND with a 0.1μF capacitor.

5 ABSOLUTE MAXIMUM RATINGS

Parameter	Parameter	Rating	UNIT
V _{CC}	Supply Voltage	+7	V
\overline{RE} , DE	Control Input Voltage	-0.3 to V _{CC} +0.3	V
DI	Driver Input voltage	-0.3 to V _{CC} +0.3	V
A, B	Receiver Input Voltage	±13	V
A, B	Driver Output Voltage	±13	V
RO	Receiver Output Voltage	-0.3 to (V _{CC} +0.3)	V
P	SO(derate 5.9mW/°C above +70°C)	471	mW
T _{OP}	Operating Temperature Range	-40 to +85	°C
T _J	Junction Temperature	+150	°C
T _{STO}	Storage Temperature Range	-65 to +150	°C
T _L	Lead Temperature(soldering, 10s)	+300	°C

Stresses beyond those listed under "Absolute Maximum Ratings" may cause permanent damage to the device. These are stress ratings only, and functional operation of the device at these or any other conditions beyond those indicated in the operational sections of the specifications is not implied. Exposure to absolute maximum rating conditions for extended periods may affect device reliability.

6 DC ELECTRICAL CHARACTERISTICS

($V_{CC} = 5V \pm 5\%$, $T_A = T_{MIN}$ to T_{MAX} . Typical values are at $V_{CC} = +5V$, $T_A = 25^\circ C$, unless otherwise noted.)⁽¹⁾

Parameter	Symbol	Test Conditions	MIN	TYP	MAX	UNIT
Driver						
Supply voltage	V_{CC}		3.0		5.5	V
Differential Driver Output(No load)	V_{OD1}	No load	1.5		5.0	V
Differential Driver Output	V_{OD2}	RL=100Ω, Figure 1	2.0		5	V
		RL=54Ω, Figure 1	1.5		5	V
Change in Magnitude of Differential Output Voltage ⁽²⁾	ΔV_{OD}	RL=54Ω, Figure 1			0.2	V
Driver Common- Mode Output Voltage	V_{OC}	RL=54Ω, Figure 1	1.0		3	V
Change in Magnitude of Common- Mode Voltage ⁽²⁾	ΔV_{OC}	RL=54Ω, Figure 1			0.2	V
Input-High Voltage	V_{IH1}	DE, DI, \overline{RE}	2.0			V
Input-Low Voltage	V_{IL1}	DE, DI, \overline{RE}			0.8	V
Input Hysteresis	V_{HYS}	DI		100		mV
Input Current(A,B)	I_{IN1}	DE=GND, V_{CC} =GND or 5V	$V_{IN}=12V$		125	μA
			$V_{IN}=-7V$	-75		
Driver Short-Circuit Output Current ⁽³⁾	I_{OSD}		$0 \leq V_{OUT} \leq +12V^{(3)}$		250	mA
			$-7V \leq V_{OUT} \leq V_{CC}^{(3)}$	-250		
			$0 \leq V_{OUT} \leq V_{CC}^{(3)}$	±25		
Receiver						
Receiver Differential Threshold Voltage	V_{TH}	$-7V \leq V_{CM} \leq 12V$	-200	-110	-50	mV
Receiver Input Hysteresis	ΔV_{TH}	$V_A + V_B = 0V$		30		mV
Receiver Output-High Voltage	V_{OH}	$I_O = -4mA, V_{ID} = -50mV$	$V_{CC} - 1.5$			V
Receiver Output-Low Voltage	V_{OL}	$I_O = 1mA, V_{ID} = -200mV$			0.4	V
Three-State Output Current at Receiver	I_{OZR}	$0.4V \leq V_O \leq 2.4V$			±1	μA
Receiver Input Resistance	R_{IN}	$-7V \leq V_{CM} \leq 12V$	96			kΩ
Receiver Output Short-Circuit Current	I_{OSR}	$0V \leq V_{RO} \leq V_{CC}$	±7		±95	mA
Supply Current						
Supply current	I_{CC}	No load, $\overline{RE} = DI = V_{CC}, DE = V_{CC}$		140	600	μA
		No load, $\overline{RE} = DI = GND, DE = GND$		110	600	
Supply Current in Shutdown Mode	I_{SHDN}	$\overline{RE} = V_{CC}, DE = GND, DI = V_{CC}$ or GND		0.1	100	μA
ESD Protection						
ESD Protection (A, B)	ESD	Human Body Mode		±15		kV
		Machine Mode		±800		V
		Contact Discharge IEC 61000-4-2		±12		kV
		Air-Gap Discharge IEC 61000-4-2		±15		
ESD Protection (other pins)	ESD	Human Body Mode		±6		kV
		Machine Mode		±400		kV

7 DRIVER SWITCHING CHARACTERISTICS

($V_{CC}=+5V\pm 5\%$, $T_A=T_{MIN}\sim T_{MAX}$, Typical values are at $V_{CC}=+5V$ and $T_A=25^\circ C$; unless otherwise noted.)⁽¹⁾

Parameter	Symbol	Conditions	MIN	TYP	MAX	UNITS
Driver Propagation Delay	t_{DPLH}	$R_L=54\Omega, C_L=50pF$, Figure 2 and Figure 3	250	720	900	ns
	t_{DPHL}		250	720	900	
Driver Output Skew $ t_{DPLH} - t_{DPHL} $	t_{DHKEW}	$R_L=54\Omega, C_L=50pF$, Figure 2 and Figure 3		-3	±100	ns
Driver Differential Output Rise or Fall Time	t_R, t_F	$R_L=54\Omega, C_L=50pF$, Figure 2 and Figure 3	200	530	750	ns
Maximum Data Rate	F_{MAX}				1	Mbps
Driver Enable to Output High	t_{DZH}	Figure 4			2500	ns
Driver Enable to Output Low	t_{DZL}	Figure 4			2500	ns
Driver Disable Time from Low	t_{DLZ}	Figure 4			100	ns
Driver Disable Time from High	t_{DHZ}	Figure 4			100	ns
Driver Enable from Shutdown to Output High	$T_{DZH(SHDN)}$	Figure 4			4500	ns
Driver Enable from Shutdown to Output Low	$t_{DZL(SHDN)}$	Figure 4			4500	ns
Time to Shutdown	t_{SHDN}		50	200	600	ns

8 RECEIVER SWITCHING CHARACTERISTICS

($V_{CC}=+5V\pm 5\%$, $T_A=T_{MIN}\sim T_{MAX}$, Typical values are at $V_{CC}=+5V$ and $T_A=25^\circ C$; unless otherwise noted.)⁽¹⁾

Parameter	Symbol	Conditions	MIN	TYP	MAX	UNITS
Receiver Propagation Delay	t_{RPLH}	Figure 5		127	200	ns
	t_{RPHL}			127	200	
Receiver Output Skew $ t_{DPLH} - t_{DPHL} $	t_{RSKEW}	Figure 5		3	±30	ns
Receiver Disable Time from High	t_{RHZ}	Figure 6		20	50	ns
Receiver Disable Time from Low	t_{RLZ}	Figure 6		20	50	ns
Receiver Enable to Output High	t_{RZH}	Figure 6		20	50	ns
Receiver Enable to Output Low	t_{RZL}	Figure 6		20	50	ns
Receiver Enable from Shutdown to Output High	$t_{RZH(SHDN)}$	Figure 6			3500	ns
Receiver Enable from Shutdown to Output Low	$t_{RZL(SHDN)}$	Figure 6			3500	ns

1. All currents into the device are positive. All currents out of the device are negative. All voltages are referred to device ground, unless otherwise noted.

2. ΔV_{OD} and ΔV_{OC} are the changes in V_{OD} and V_{OC} , respectively, when the DI input changes state.

3. The short-circuit output current applies to peak current just prior to foldback current limiting. The short-circuit foldback output current applies during current limiting to allow a recovery from bus contention.

9 TEST CIRCUITS AND WAVEFORMS

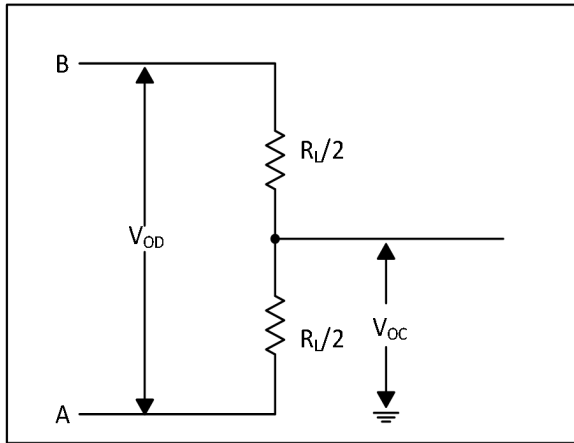

Figure 1. Driver DC Test Load

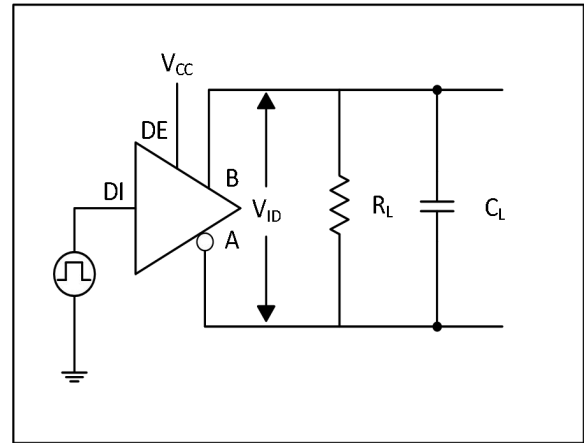

Figure 2. Driver timing test load

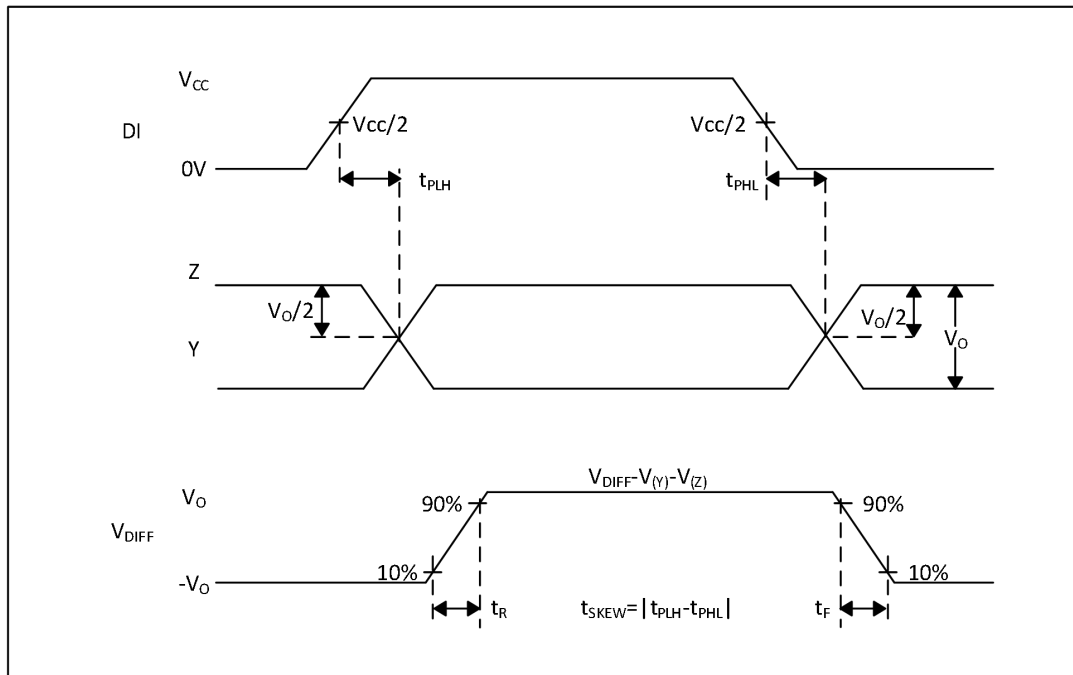

Figure 3. Driver Propagation Delays

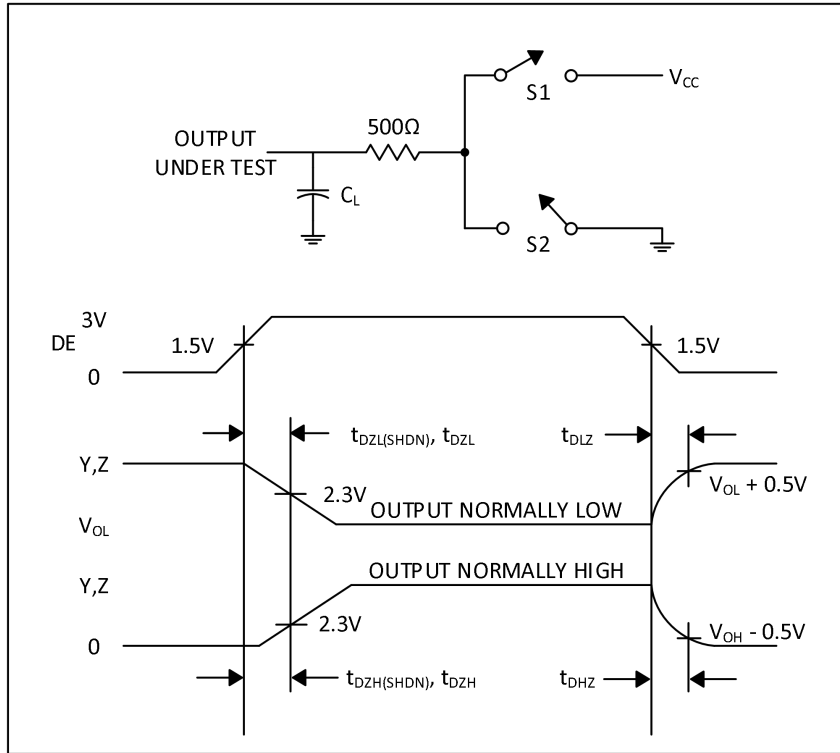

Figure 4. Driver Enable and Disable Times

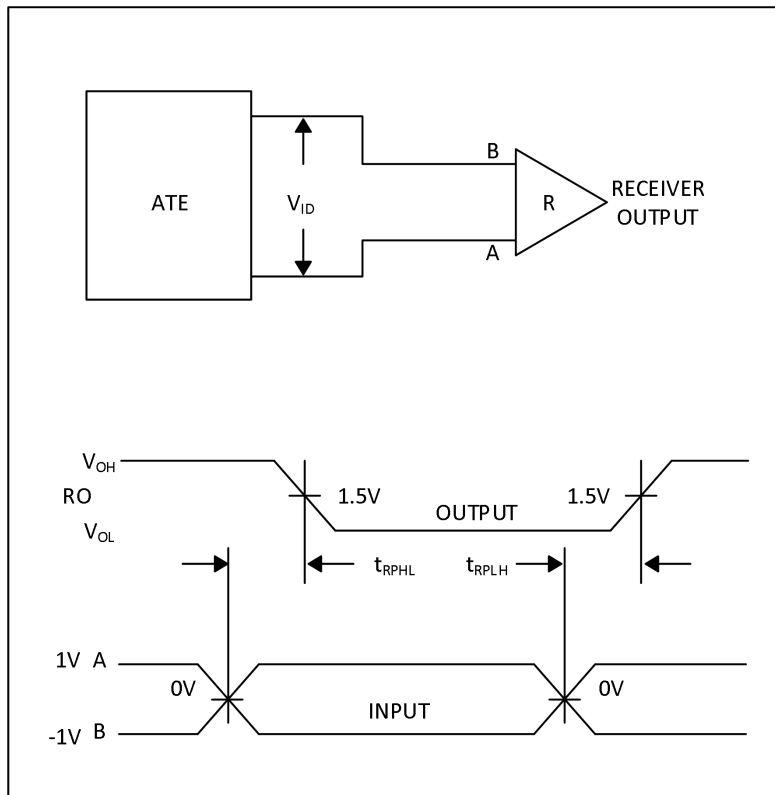

Figure 5. Receiver Propagation Delays

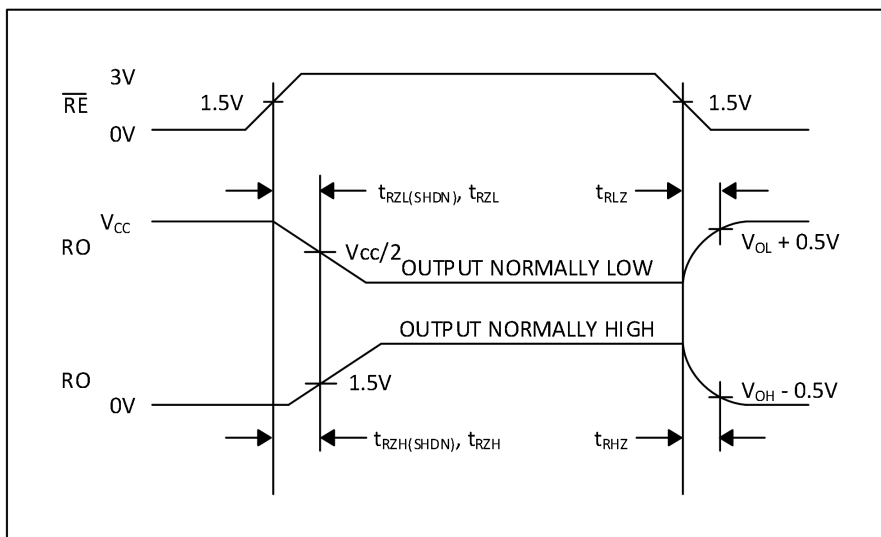
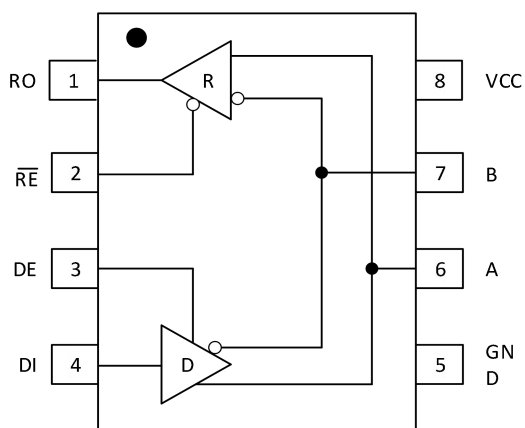

Figure 6. Receiver Enable and Disable Times

10 FUNCTION TABLES



TRANSMITTING				
CONTROL		INPUTS	OUTPUTS	
RE	DE	DI	A	B
X	1	1	1	0
X	1	0	0	1
0	0	X	Z	Z
1	0	X	Shutdown	
RECEIVING				
CONTROL		INPUTS	OUTPUTS	
RE	DE	A - B	RO	
0	X	≥ -50mV	1	
0	X	≤ -200mV	0	
0	X	Open/Shorted	1	
1	1	X	Z	
1	0	X	Shutdown	

11 Detailed Description

11.1 Overview

The YD3082E high-speed transceiver for RS-485 communication contains one driver and one receiver. These devices feature fail-safe circuitry, which guarantees a logic-high receiver output when the receiver inputs are open or shorted, or when they are connected to a terminated transmission line with all drivers disabled (see the Fail-Safe section). The YD3082E driver slew rate is not limited, making transmit speeds up to 1Mbps possible. The YD3082E is a half-duplex transceiver. The voltage operates from a single +3.0~+5.5V supply. Drivers are output short-circuit current limited. Thermal shutdown circuitry protects drivers against excessive power dissipation. When activated, the thermal shutdown circuitry places the driver outputs into a high impedance state.

11.2 ESD Protection

ESD-protection structures are incorporated on all pins to protect against electrostatic discharges encountered during handling and assembly. The driver output and receiver input of the YD3082E has extra protection against static electricity. The ESD-protected pins are tested with reference to the ground pin in a powered-down condition. They are tested to ±15kV using the Human Body Model.

11.3 Fail-Safe

The YD3082E guarantees a logic-high receiver output when the receiver inputs are shorted or open, or when they are connected to a terminated transmission line with all drivers disabled. This is done by setting the receiver threshold between -50mV and -200mV. If the differential receiver input voltage (A - B) is greater than or equal to -50mV, RO is logic high. If A - B is less than or equal to -200mV, RO is logic low. In the case of a terminated bus with all transmitters disabled, the receiver's differential input voltage is pulled to 0V by the termination. With the receiver thresholds of the YD3082E, this results in a logic high with a 50mV minimum noise margin. Unlike previous fail-safe devices, the -50mV to -200mV threshold complies with the ±200mV EIA/TIA-485 standard.

11.4 32 Transceivers on the Bus

The standard RS-485 receiver input impedance is 12kΩ (one-unit load), and the standard driver can drive up to 32 unit loads. The YD3082E has a 1/8-unit-load receiver input impedance (96kΩ), allowing up to 256 transceivers to be connected in parallel on one communication line. Any combination of this device and/or other RS-485 transceivers with a total of 32 unit loads or less can be connected to the line.

11.5 Reduced EMI and Reflections

The YD3082E, driver slew rate is not limited, High-frequency harmonic components with large amplitudes are evident. transmitting under the same conditions. In general, a transmitter's rise time relates directly to the length of an unterminated stub, which can be driven with only minor waveform reflections. The following equation expresses this relationship conservatively: $Length = T_{RISE} / (10 \times 1.5ns / F_t)$, where T_{RISE} is the transmitter's rise time.

11.6 Machine Model

The Machine Model for ESD tests all pins using a 200pF storage capacitor and zero discharge resistance. The objective is to emulate the stress caused when I/O pins are contacted by handling equipment during test and assembly. All pins require this protection, not just RS-485 inputs and outputs.

11.7 Human Body Model

Figure 7a shows the Human Body Model, and Figure 7b shows the current waveform it generates when discharged into a low impedance. This model consists of a 100pF capacitor charged to the ESD voltage of interest, which is then discharged into the test device through a 1.5kΩ resistor.

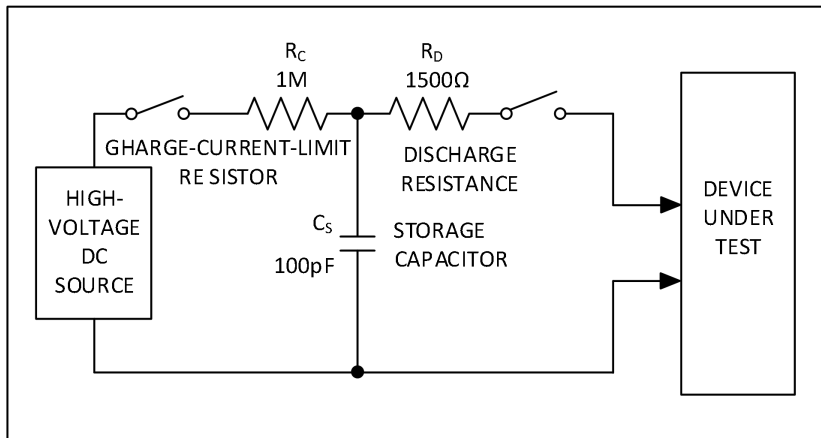

Figure 7a. Human Body ESD Test Model

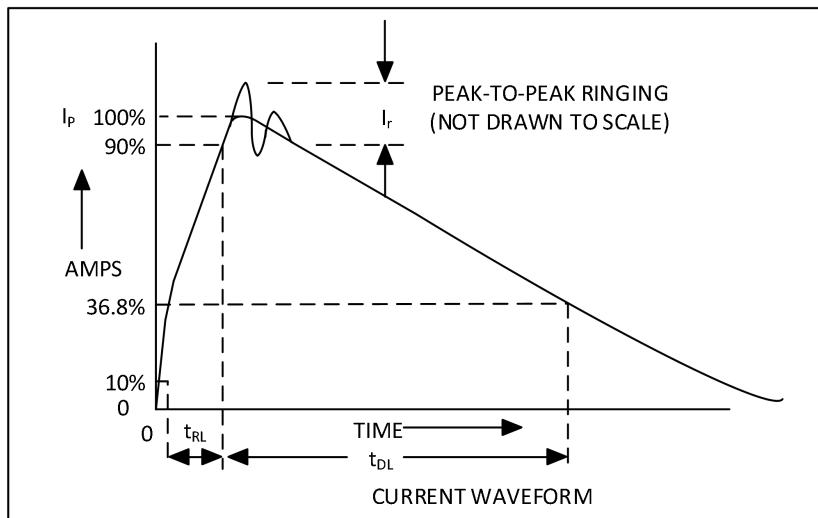

Figure 7b. Human Body Current Waveform

11.8 Line Length vs Data Rate

The RS-485/RS-422 standard covers line lengths up to 4000 feet. For line lengths greater than 4000 feet, use the repeater application shows in [Figure 8](#).

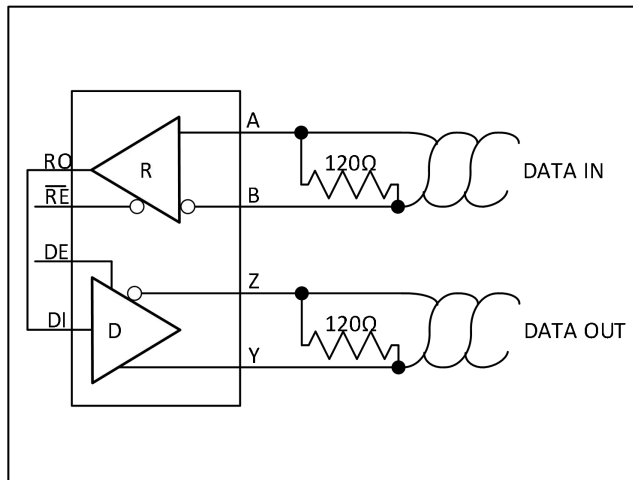

Figure 8. Line repeater for YD3082E

12 TYPICAL APPLICATION

The standard RS-485 receiver input impedance is 12kΩ (1-unit load), and the standard driver can drive up to 32-unit loads. The YD3082E has a 1/8-unit load receiver input impedance (96kΩ), allowing up to 256 transceivers to be connected in parallel on one communication line. Any combination of the YD3082E, as well as other RS-485 transceivers with a total of 32-unit loads or fewer, can be connected to the line.

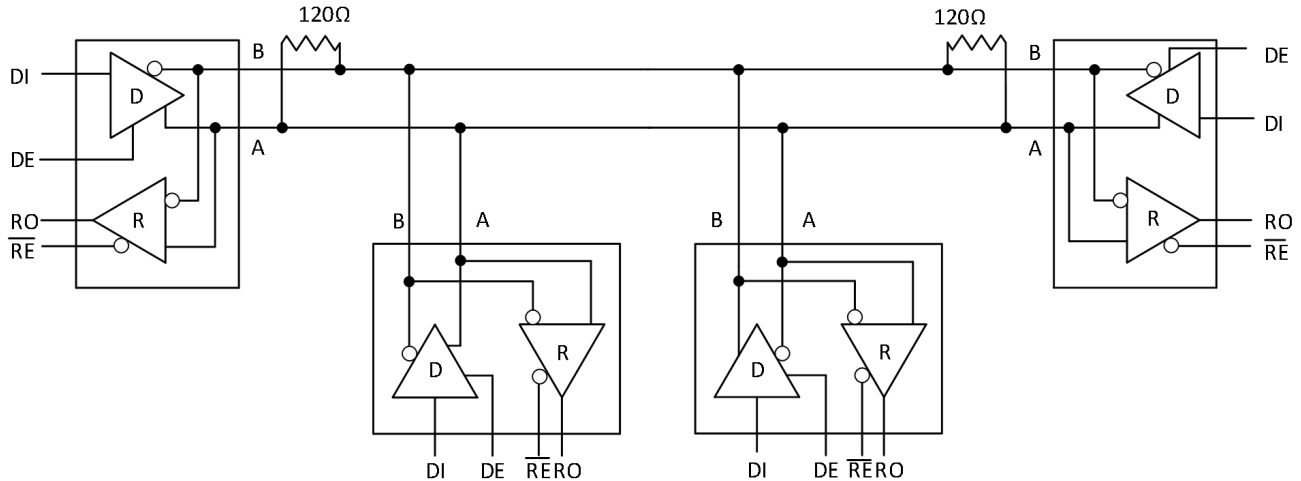
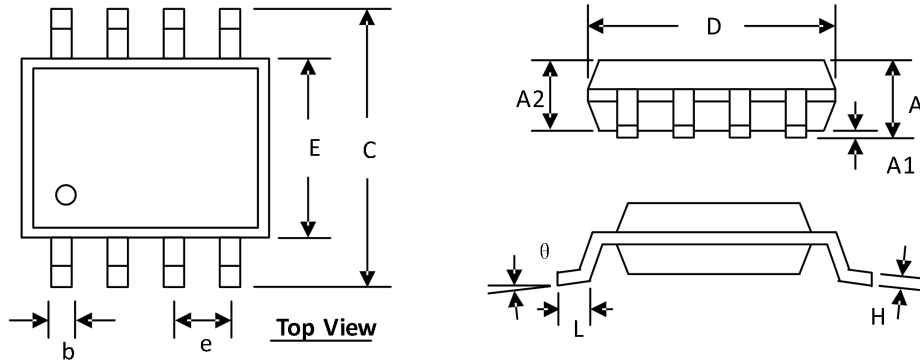

Figure 9. Typical half-duplex RS-485 Network

PACKAGE DIMENSION SOP8

SYMBOLS	DIMENSION (MM)		DIMENSION (INCH)	
	MIN	MAX	MIN	MAX
A	1.300	1.752	0.051	0.069
A1	0.000	0.203	0.000	0.008
A2	1.350	1.550	0.053	0.061
b	0.330	0.510	0.013	0.020
C	5.790	6.200	0.228	0.244
D	4.700	5.110	0.185	0.201
E	3.800	4.000	0.150	0.157
e	1.270 BSC		0.050 BSC	
H	0.170	0.254	0.007	0.010
L	0.400	1.270	0.016	0.050
θ	0°	8°	0°	8°

Order Information

Order number	Package	Marking information	Operation Temperature Range	MSL Grade	Ship, Quantity	Green
YD3082ESA	SOP8	YD3082EESA	-40 to 85°C	3	T&R, 2500	Rohs