

SOT-323 Plastic-Encapsulate Transistors

TRANSISTOR (PNP)

FEATURES

- Ideally suited for automatic insertion
- Epitaxial planar die construction
- Complementary to BC817W

MAXIMUM RATINGS (T_a=25°C unless otherwise noted)

Symbol	Parameter	Value	Unit
V _{CB0}	Collector-Base Voltage	-50	V
V _{CEO}	Collector-Emitter Voltage	-45	V
V _{EBO}	Emitter-Base Voltage	-5	V
I _C	Collector Current	-500	mA
P _C	Collector Power Dissipation	200	mW
R _{θJA}	Thermal Resistance From Junction To Ambient	417	°C/W
T _j	Junction Temperature	150	°C
T _{stg}	Storage Temperature	-55~+150	°C

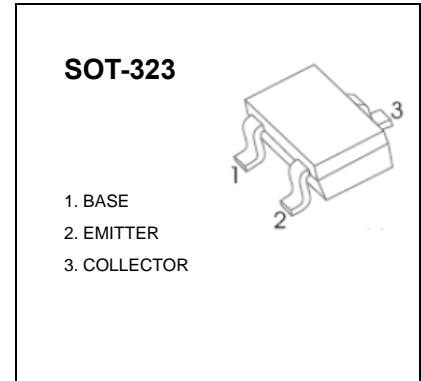

ELECTRICAL CHARACTERISTICS (T_a=25°C unless otherwise specified)

Parameter	Symbol	Test conditions	Min	Max	Unit
Collector-base breakdown voltage	V _{CB0}	I _C =-10μA, I _E =0	-50		V
Collector-emitter breakdown voltage	V _{CEO}	I _C =-10mA, I _B =0	-45		V
Emitter-base breakdown voltage	V _{EBO}	I _E =-1μA, I _C =0	-5		V
Collector cut-off current	I _{CBO}	V _{CB} =-20 V, I _E =0		-0.1	μA
Collector cut-off current	I _{CEO}	V _{CE} =-20 V, I _B =0		-0.2	μA
Emitter cut-off current	I _{EBO}	V _{EB} =-5 V, I _C =0		-0.1	μA
DC current gain	h _{FE(1)}	V _{CE} =-1V, I _C =-100mA	100	600	
	h _{FE(2)}	V _{CE} =-1V, I _C =-500mA	40		
Collector-emitter saturation voltage	V _{CE(sat)}	I _C =-500mA, I _B =-50 mA		-0.7	V
Base-emitter voltage	V _{BE(on)}	V _{CE} =-1V, I _C =-500mA		-1.2	V
Transition frequency	f _T	V _{CE} =-5 V, I _C =-10mA f=100MHz	80		MHz
Collector output capacitance	C _{ob}	V _{CB} =-10V, f=1MHz		10	pF

CLASSIFICATION of h_{FE(1)}

Rank	BC807-16W	BC807-25W	BC807-40W
Range	100-250	160-400	250-600
Marking	5A	5B	5C

Typical Characteristics

