

标记 MARK	ECN编号/变更内容 ECN NO/DEFINITION	修改 REVISE	日期 DATE	核准 APPROVE

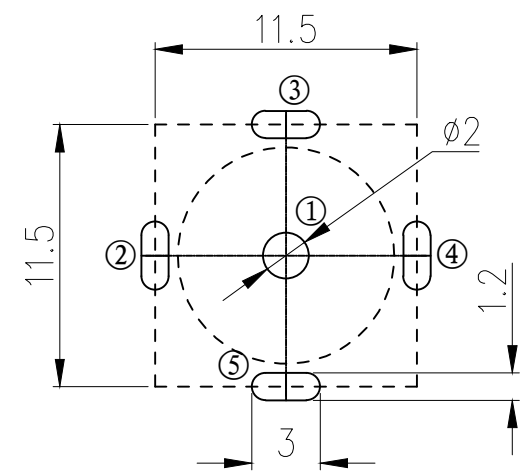
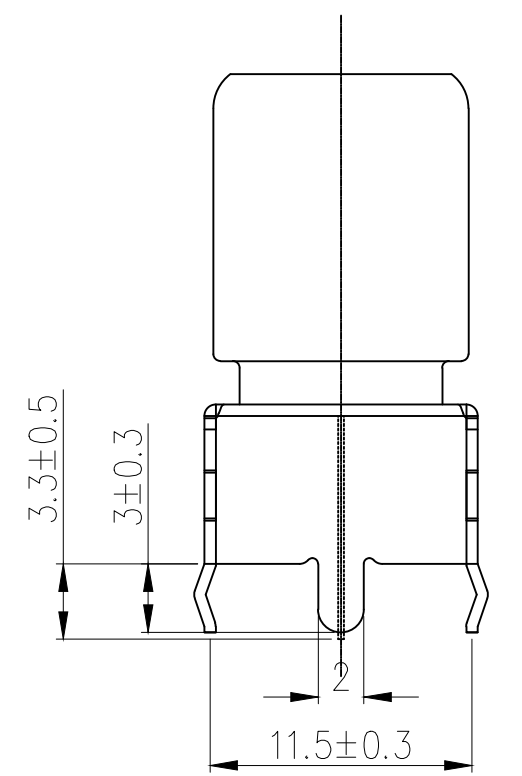
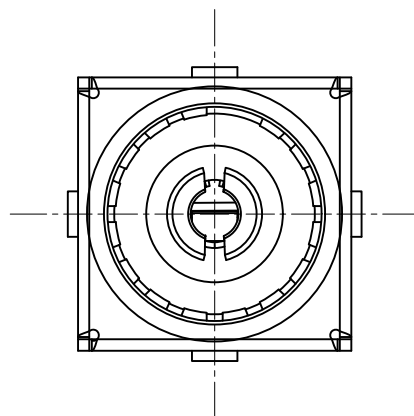
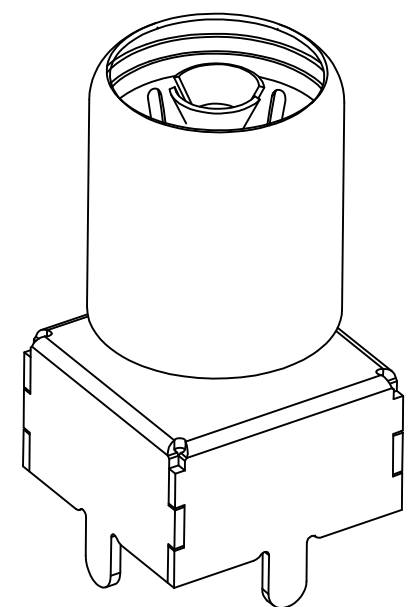
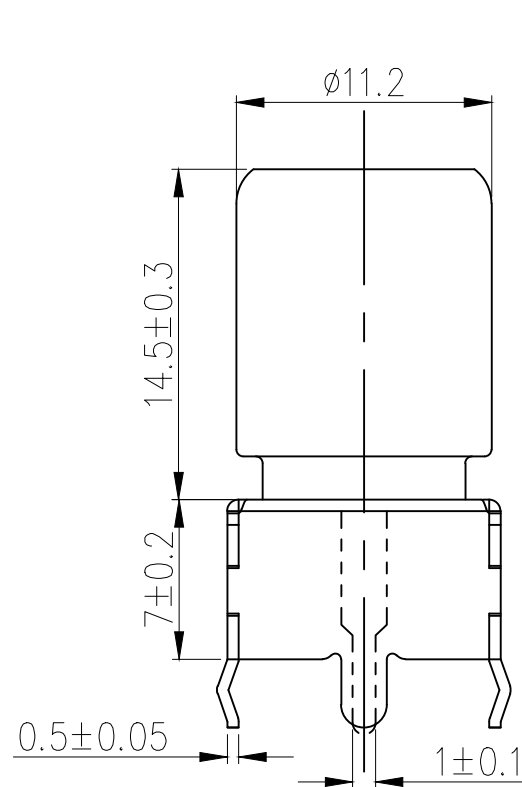

**PCB LAYOUT
(TOP VIEW)**
P. C. B开孔示意图

SPECIFICATION (技术要求)

1. Operating Temperature (环境温度): -25°C ~ 85°C
2. Voltage Rating (额定电压): 50V AC/DC
3. Current Rating (额定电流): 0.5A
4. Contact Resistance (接触抗阻): 30mΩ
5. Insulation Resistance (绝缘抗阻): 100MΩ
6. Dielectric Withstanding Voltage (耐电压): 500V AC Min
7. Insertion/Withdrawal Force (插拔力): 3-50N
8. Life Time (mating cycles) 寿命: >1000 Cycles
9. SIGNAL LOSS < 1dB IN BOTH VHF, UHF BAND.
10. NOMINAL IMPEDANCE : 75 OHMS.
11. OPERATING FREQUENCY : 0-2 GHZ.

3	IEC母头	冷扎板	镀镍	
2	支架	冷扎板	CuSn	
1	绝缘体	PPS	黑色	
序号	品名	材质	电镀/颜色	备注

	深圳市虹成电子有限公司		品名 TITLE	屏蔽罩	
			料号 PART NO	HC-PBZ-I1212	
GENERAL TOLERANCES (UNLESS SPECIFIED)		比列 SCALE	1:1		
0-10: ±0.2	26-50: ±0.4	单位 UNIT	MM	制图 DRAW	AhYe
11-25: ±0.3	ANGULAR: ±2°	张数 PART NO	1 OF 1	审核 CHECKED	夏操云
		版本 REV	A	批准 APPROVE	赵亮亮



A
B
C
D
E
F
G

A
B
C
D
E
F
G