

# SPECIFICATION FOR APPROVAL

客户名称 (CUSTOMERS):	
客户料号 (CUSTOMERS M. NO):	
乔光产品料号 (OUR PN):	FTR10D681KJ
品名规格 (SEPCIFICATION):	FTR10D681KJ
日期 (DATE):	2025/03/21
版次 (Revision No.)	A00

制造商确认 MANUFACTURE			客户确认 CUSTOMER		
拟制 DESIGNER	审核 CHECKER	批准 APPROVED	拟制 DESIGNER	审核 CHECKER	批准 APPROVED
黄建南	吴尚书	查泽军			
承认章			承认章		

客户确认签核盖章后, 请回传一份承认书给我公司。

PLEASE RETURN TO US A COPY OF "SPECIFICATION FOR APPROVAL" WITH YOU APPROVED SIGNATURE.

金属氧化物压敏电阻(MOV)规格书

Metal Oxide Varistors (MOV) Data Sheet

特性 Features

- 快速响应瞬态过电压, Fast responding to transient over-voltage
- 较大的吸收瞬态能量能力, Large absorbing transient energy capability
- 低残压要求和低漏电流, Low clamping ratio and no follow-on current
- 满足 RoHS 要求, RoHS Compliant
- 工作温度:  $-40^{\circ}\text{C} \sim +125^{\circ}\text{C}$ , Operating Temperature:  $-40^{\circ}\text{C} \sim +125^{\circ}\text{C}$
- 存储条件温湿度:  $-10^{\circ}\text{C} \sim +40^{\circ}\text{C}$  and  $\leq 70\%RH$ , Storage Temperature and Humidity:  $-10^{\circ}\text{C} \sim +40^{\circ}\text{C}$  and  $\leq 70\%RH$
- 存储期限:  $\leq 12$  个月, Storage Life:  $\leq 12$  months

应用 Applications

- 电源、电信通信、智能电表或 PLC 保护 Power supply, Telecommunication, Smart meter, or PLC protection
- 消费类电子产品浪涌保护 Surge protection in consumer electronics
- 工业电子设备浪涌保护 Surge protection in industrial electronics
- 家用电器类浪涌保护 Surge protection in electronic home appliances, gas and petroleum appliances
- 继电器和电磁阀浪涌吸收量 Relay and electromagnetic valve surge absorption

1, 产品编码说明 Part Number Code:

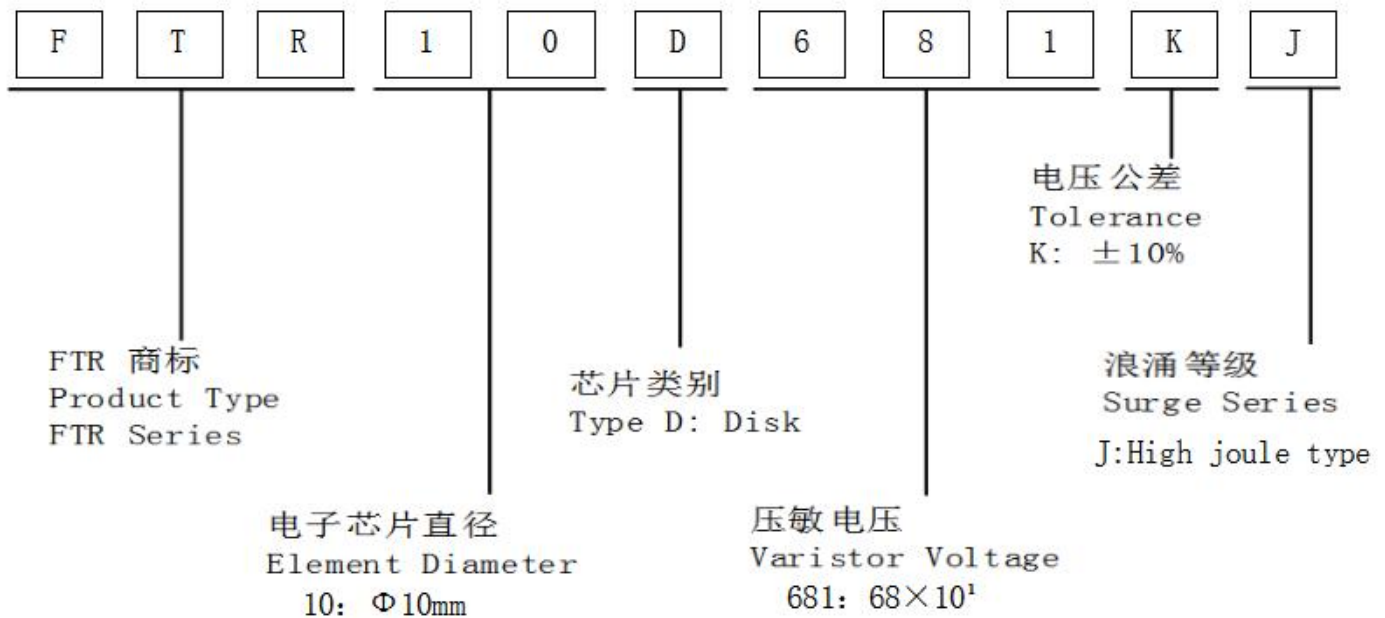

2, 电气特性 Electrical Characteristics:

最大持续使用电压 Maximum Allowable Voltage		压敏电压 (25±2℃) Varistor Voltage	最大限制电压 Maximum Clamping Voltage		浪涌电流 Surge Current	最大能量 Maximum Energy (10/1000µs)	功率 Rated Power
V <sub>AC</sub> (V)	V <sub>DC</sub> (V)	V <sub>1mA</sub> (V)	I <sub>P</sub> (A)	V <sub>C</sub> (V)	I <sub>max 8/20us</sub> (A)	(J)	(W)
420	560	680 (612~748)	25	1120	3500	98	0.4

备注 Notes: 1, 漏电流 Leakage Current (@83% of V<sub>1mA</sub>): IR ≤ 25 µA , @ ≥ 25 at 25 ± 2℃

3, 外形尺寸 Dimensions:

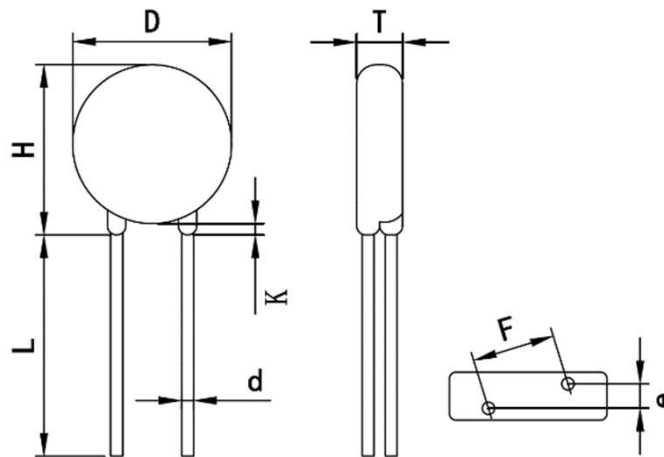

符号 Symbol	D(max.)	H(max.)	L(min.)	F	d(±0.05)	T(max.)	e
外形尺寸 Dimension(mm)	12	14.5	20	7.5 ± 0.5	0.80	6.4	4.2 ± 0.8

4, 产品印码 Marking Code:

	FTR	Logo
	10D681KJ	Product Model
	安规 Safety certificate	UL&CSA Certificate No. :E507891 CQC Certificate No. : FTR07D* CQC20001268211      FTR10D* CQC20001268175 FTR14D* CQC20001268254      FTR20D* CQC20001268253
		VDE Certificate No. :40051843 K F Date code

5, 电气特性指标 Electrical Ratings:

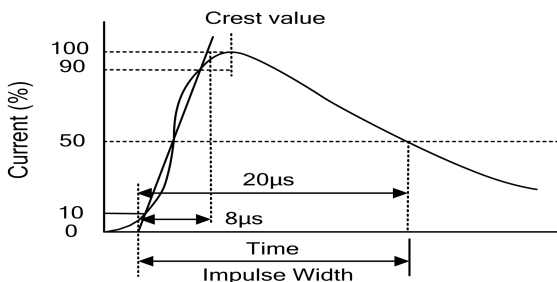
项目 Items	测试条件 / 说明 Test Condition/Description	要求 Requirement					
压敏电阻 Varistor Voltage	在直流参考电流为1mA的条件下，测试压敏电阻两引线端的电压 The voltage between two terminals with the specified measuring current 1mA.DC applied is called Vb.						
最大持续使用电压 Maximum Allowable Voltage	压敏电阻正常能承受的最大直流或交流电压 The recommended maximum sine wave voltage (RMS) or the Maximum DC voltage can be applied continuously.						
最大限制电压 Maximum Clamping Voltage	在固定 8/20us 波形，规定的脉冲峰值电流 (Ip) 条件下，测得的压敏电阻的电压峰值, The maximum voltage between two terminals with the specification standard impulse current. Applied waveform: 8/20 μ s 	测试结果满足或符合规格要求值 To meet the Specified value					
功率级别 Rated Wattage	在指定的环境温度内可施加的最大平均功率 The maximum average power that can be applied within the specified ambient temperature.						
能量 Energy	当施加了 10/1000 μ s 或 2ms 的一个脉冲波形时，压敏电阻电压变化率 ±10% 的范围内能吸收的最大能量。The maximum energy within the varistor voltage change of ±10% when one impulse of 10/1000 μ s or 2ms is applied.						
浪涌电流冲击能力 Withstanding Surge Current	对压敏电阻施加一个标准脉冲 (8/20 μ s) 电流，压敏电阻的电压变化率需满足在 ±10% 的范围内。The maximum current within the varistor voltage change of ±10% with the standard impulse current (8/20 μ s) applied.						
压敏电阻温度系数 Varistor Voltage Temp. Coefficient	$\left  \frac{V_{1mA@85^{\circ}C} - V_{1mA@25^{\circ}C}}{V_{1mA@25^{\circ}C}} \times \frac{1}{60} \times 100\% (\%/^{\circ}C) \right $ $\left  \frac{V_{1mA@-40^{\circ}C} - V_{1mA@25^{\circ}C}}{V_{1mA@25^{\circ}C}} \times \frac{1}{65} \times 100\% (\%/^{\circ}C) \right $	≤0.05%/°C					
浪涌寿命 Surge Life	在室温条件下，按下表所述的脉冲电流和波形条件下连续施加 10,000 次后测量压敏电阻的电压 Vb 的变化, The change of Vb shall be measured after the impulse listed below which is applied 10,000 times continuously with the interval of ten seconds at room temperature <table border="1" data-bbox="502 1859 1141 1971"> <tr> <td rowspan="2">10Φ series</td> <td>180K to 680K</td> <td>50A (8/20 μ s)</td> </tr> <tr> <td>820K to 112K</td> <td>100A (8/20 μ s)</td> </tr> </table>	10Φ series	180K to 680K	50A (8/20 μ s)	820K to 112K	100A (8/20 μ s)	$\frac{\Delta V_b}{V_b} \leq \pm 10\%$
10Φ series	180K to 680K		50A (8/20 μ s)				
	820K to 112K	100A (8/20 μ s)					

6. 机械特性 Mechanical Characteristics:

项目 Items	测试条件 / 方法 Test conditions / Methods	规格 Specifications
引线抗位强度 Tensile Strength of Terminals	在端子两端逐渐施加固定的拉力，保持装置固定 10±1 秒。 Gradually applying the force specified and keeping the unit fixed for 10±1 sec. Terminal diameter (mm) Froce(kg) 0.5<d≤0.8 1.0 0.8<d≤1.25 2.0 1.25<d 4.0	本体无明显的损坏 NO Visible damage   ΔV1mA/V1mA   ≤5%
引线弯曲强度测试 Bending Strength of Terminals	对待测试的样品每根导线施加以下规定的力度, 将试样弯曲至 90° , 然后回到原始位置。在相反的方向上重复该步骤。 Hold specimen and apply the force specified below to each lead. Bend the specimen to 90° , then return to the original position. Repeat the procedure in the opposite direction. Terminal diameter (mm) Froce(kg) 0.5<d≤0.8 0.5 0.8<d≤1.25 1.0 1.25<d 2.0	本体无明显的损坏 NO Visible damage   ΔV1mA/V1mA   ≤5%
振运测试 Vibration	频率范围: 10~55Hz Frequency range: 10~55 Hz 振幅: 0.75 毫米或 98m/s2 Amplitude: 0.75mm or 98m/s2 方向: 3 个相互垂直的方向, 每个方向为 2 小时。Direction: 3 mutually perpendicular directions, 2hrs each.	本体无明显的损坏 NO Visible damage   ΔV1mA/V1mA   ≤5%
焊锡性 Solder ability	焊接温度: 245±5°C Solder Temp: 245±5°C 浸焊时间: 2±0.5 sec Dipping Time: 2±0.5 sec	至少 95%的端子电极被新的焊料覆盖 At least 95% of terminal electrode is covered by new solder
耐焊热测试 Resistance to Soldering Heat	焊接温度: 260±5°C Solder Temp: 260±5°C 浸焊时间: 10±1 sec Dipping Time: 10±1 sec	本体无明显的损坏 NO Visible damage   ΔV1mA/V1mA   ≤5%

7, 可靠性 Reliability:

项目 Items	测试条件/方法 Test conditions / Methods	规格 Specifications															
高温储存 High Temperature Storage	环境温度: 125±2℃ Ambient Temp: 125±2℃ 持续时间: 1000 小时 Duration: 1000hrs	ΔV1mA/V1mA   ≤5%															
低温储存 Low Temperature Storage	环境温度: -40±2℃ Ambient Temp: -40±2℃ 持续时间: 1000 小时 Duration: 1000hrs	ΔV1mA/V1mA   ≤5%															
高湿储存 Humidity	环境温度: 40±2℃ 90~95%R/H, Ambient Temp: 40±2℃ 90~95% R/H. 持续时间: 1000 小时 Duration: 1000hrs	ΔV1mA/V1mA   ≤5%															
温度循环 Temperature Cycle	<p>以下条件应重复 5 个循环 The conditions shown below shall be repeated 5 cycles</p> <table border="1"> <thead> <tr> <th>步骤 Step</th> <th>温度 Temperature (°C)</th> <th>周期 Period (minutes)</th> </tr> </thead> <tbody> <tr> <td>1</td> <td>-40±3</td> <td>30±3</td> </tr> <tr> <td>2</td> <td>Room temperature</td> <td>5±3</td> </tr> <tr> <td>3</td> <td>125±3</td> <td>30±3</td> </tr> <tr> <td>4</td> <td>Room temperature</td> <td>5±3</td> </tr> </tbody> </table>	步骤 Step	温度 Temperature (°C)	周期 Period (minutes)	1	-40±3	30±3	2	Room temperature	5±3	3	125±3	30±3	4	Room temperature	5±3	<p>本体无明显的损伤 No visible damage</p> <p>  ΔV1mA/V1mA   ≤5%</p>
步骤 Step	温度 Temperature (°C)	周期 Period (minutes)															
1	-40±3	30±3															
2	Room temperature	5±3															
3	125±3	30±3															
4	Room temperature	5±3															
高温负载 High Temperature Load	环境温度: 125±2℃ 持续时间: 1000 小时, 负载: 最大持续交流电压。 Ambient Temp: 125±2℃ Duration: 1000hrs Load: Max. Allowable Voltage In AC eara.	ΔV1mA/V1mA   ≤10%															
湿热负载 Damp Heat Load	环境温度: 40±2℃, 90-95%R/H 相对湿度。持续时间: 1000 小时 负载: 最大交流连续使用电压, Ambient Temp: 40±2℃, 90-95% R.H. Duration: 1000hrs Load: Max. Allowable Voltage	<p>本体无明显的损伤 No visible damage</p> <p>  ΔV1mA/V1mA   ≤5%</p>															
绝缘阻抗 Voltage Proof	金属球法, 2500Vac1min. Metal balls method, 2500Vac 1 min.	<p>本体无明显的损伤 No visible damage</p>															

8, 焊接条件建议 Soldering Recommendation:

波峰无铅焊接推荐条件:

Wave Lead Free Soldering Recommendation:

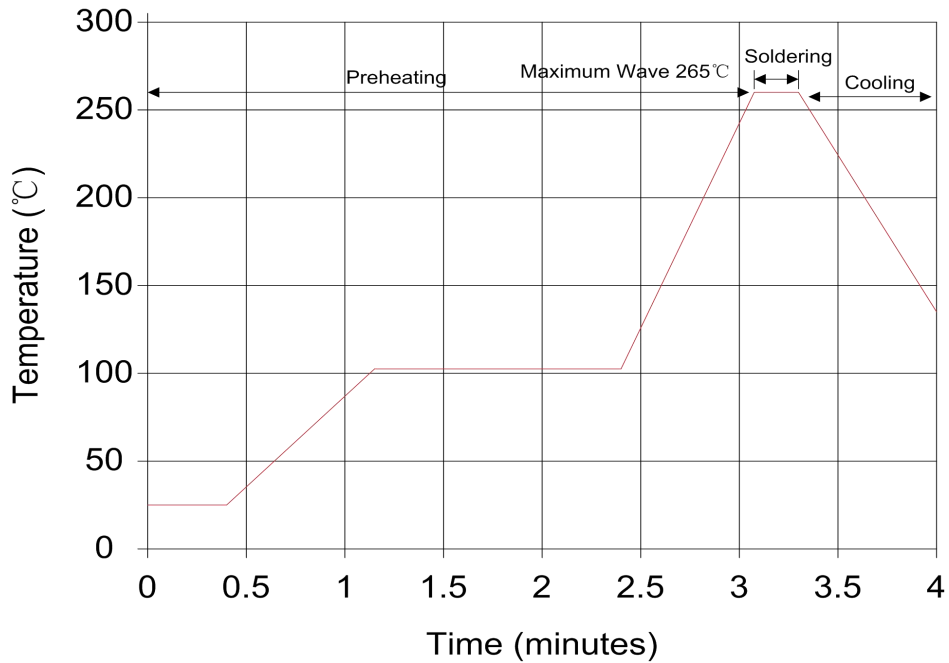







Item	Conditions
Peak Temperature	265°C
Dipping Time	10 seconds (max.)
Soldering	1 time

手工焊接推荐条件 Recommendation Reworking Conditions with Soldering Iron

Item	Conditions
Temperature of Soldering Iron-tip	360°C (max.)
Soldering Time	3 seconds (max.)
Distance from Varistor	2mm (min.)

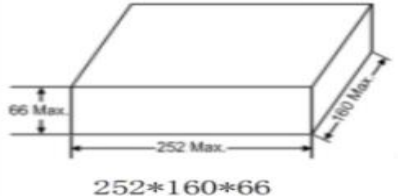
9, 包装方式 Type and Quantity of packaging:

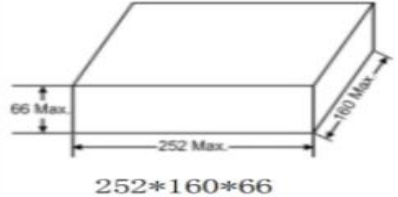
规格型号 Part Number			散装 (In bulk)									
			拔脚每袋 qty/bag (pcs)	拔脚每盒 Inner box		拔脚每箱 Carton		剪脚每袋 qty/bag (pcs)	剪脚每盒 Inner box		剪脚每箱 Carton	
				袋数 Bags/box	总数量 Total qty pcs/box	盒数 Boxes/carton	总数量 Total qty pcs/carton		袋数 Bags/box	总数量 Total Qty pcs/box	盒数 Boxes/carton	总数量 Total qty pcs/carton
数量 QTY	05D	180K~911K	1000	4	4000	4	16000	1000	4	4000	4	16000
	07D	180K~911K	1000	4	4000	4	16000	1000	4	4000	4	16000
	10D	180K~621K	500	4	2000	4	8000	500	4	2000	4	8000
		681K~112K	400	4	1600	4	6400	400	4	1600	4	6400
		122K~182K	300	4	1200	4	4800	300	4	1200	4	4800
	14D	180K~331K	400	4	1600	4	6400	400	4	1600	4	6400
		361K~621K	300	4	1200	4	4800	300	4	1200	4	4800
		681K~112K	250	4	1000	4	4000	250	4	1000	4	4000
		122K~182K	150	4	600	4	2400	150	4	600	4	2400
	20D	180K~301K	250	4	1000	4	4000	250	2	500	4	2000
		331K~561K	200	4	800	4	3200	200	2	400	4	1600
		621K~112K	150	4	600	4	2400	150	2	300	4	1200
		122K~182K	100	4	400	4	1600	100	2	200	4	800
	25D	180K~621K	100	4	400	4	1600	100	4	400	4	1600
		681K~112K	50	4	200	4	800	50	4	200	4	800

适应范围	内盒尺寸	内盒数量	外箱尺寸	每箱数量
1. 所有拔脚产品、	 <p>250*165*130</p>	4包/盒	 <p>2号箱 360*270*280</p>	4盒/箱 (16包/箱)
05D、07D、10D、14D、25D剪脚产品	 <p>252*160*66</p>	4包/盒	 <p>1号箱 260*180*280</p>	4盒/箱 (16包/箱)
20D剪脚产品	 <p>252*160*66</p>	2包/盒	 <p>1号箱 260*180*280</p>	4盒/箱 (8包/箱)

## 修订履历表 Revision History

No	变更内容 Revise Contents	变更日期 Revise Date	版次 Revision No.	负责人 Signature
1	新制定	2025/03/21	A00	黄建南
2				
3				
4				
5				
6				
7				