

标记 MARK	ECN编号/变更内容 ECN NO/DEFINITION	修改 REVISE	日期 DATE	核准 APPROVE

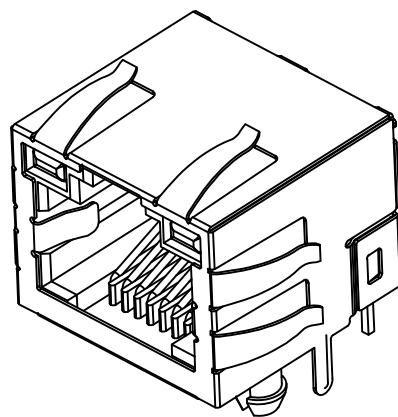

3D VIEW

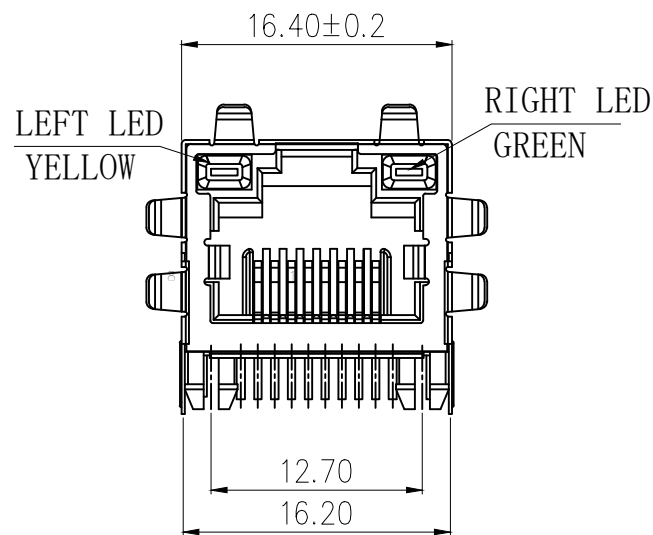
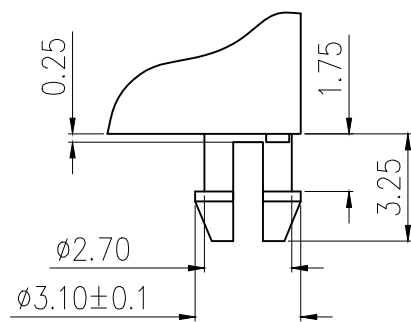
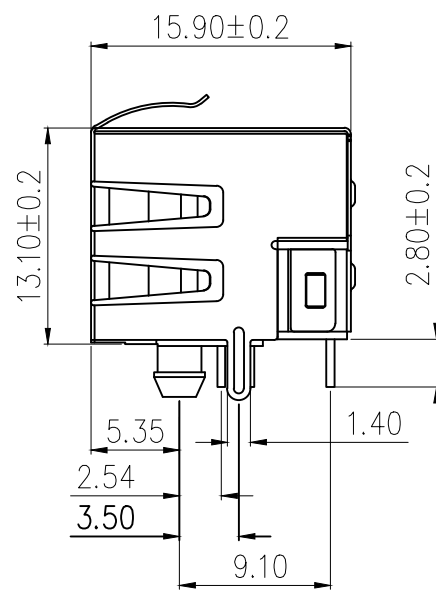
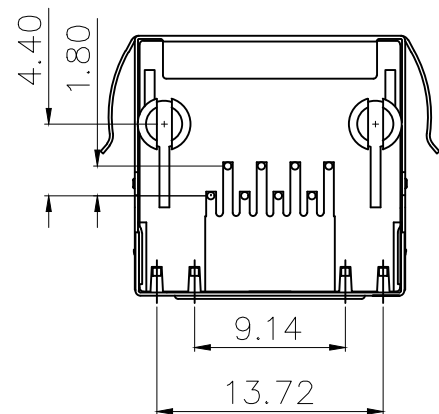

DETAIL "X"
SCALE 2:1

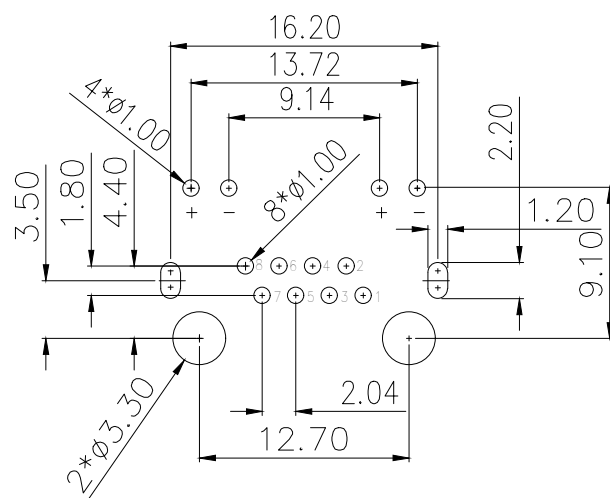

RECOMMENDER P. C. B. LAYOUT TOP VIEW
(COMPONENT SIDE TOLERANCE ±0.05)

NOTES:

- MATERIAL:
 - HOUSING: PBT ,COLOR IS BLACK;
 - CONTACT: PHOSPHOR BRONZE, $\phi 0.46 \pm 0.02$ mm;
 - SHELL: BRASS T= 0.2 ± 0.02 mm;
- FINISH:
 - CONTACT: PLATED GOLD OVER NI;
 - SHELL: NI OVER ALL;
- RECINNEBDED PCB THICKNESS: 1.60mm;
- ELECTRICAL:
 - VOLTAGE RATING: 125 VAC RMS;
 - CURRENT RATING: 1.5 AMP;
 - CONTACT RESISTANCE: 35MILLIOHMS MAX.;
 - WITHSTAND VOLTAGE: 1000 VAC RMS 50(60)Hz,1MIN.;
 - INSULATION RESISTANCE: 1000MEGOHMS MIN @500V DC;
- MECHANICAL:
 - MATING/UNMATING FORCE: 25N MAX.;
 - RETENTION STRENGTH: 50N MIN.;
 - OPERATING LIFE: 750 CYCLES MIN.;
- SALT SPRAY TEST: 12H(Excluding riveted bends);
- SOLDERABILITY: $245 \pm 5^\circ\text{C}, 5 \pm 0.5\text{S}$;
- RESISTANCE TO SOLDER: $260 \pm 5^\circ\text{C}, 10 \pm 1\text{S}$;
- ENVIRONMENTAL:
 - STORAGE TEMPERATURE RANGE: $-40^\circ\text{C} \sim +85^\circ\text{C}$;
 - OPERATION TEMPERATURE RANGE: $-25^\circ\text{C} \sim +70^\circ\text{C}$;
- MATES WITH: MODULAR PLUGS THAT CONFORM TO FCC REGULATION PART 68.500;

3	外壳	铜	镀镍	
2	接触	铜	镀金G/F	
1	基座	PBT	黑色	
序号	品名	材质	电镀/颜色	备注

	深圳市虹成电子有限公司		品名 TITLE	网口	
			料号 PART NO	HC-WK88-H16-DKT	
UNLESS OTHERWISE, GENERAL TOLERANCE:		比列 SCALE	1:1		
X. xxx ±0.10 X. xx ±0.20 X. x ±0.30		单位 UNIT	MM	制图 DRAW	AhYe
ANGULAR: X. xx° ±1° X. x° ±3° X. ° ±5°		张数 PART NO	1 OF 1	审核 CHECKED	夏操云
		版本 REV	A	批准 APPROVE	赵亮亮

