

1 FEATURES

- 2.5V to 5.5V input voltage
- Output adjustable from up to 30V
- Internal 3A Switch Current Limit Typically
- Integrated 100mΩ Power MOSFET
- Fixed frequency 1.2MHz
- Automatic PFM at Light Loads
- Internal compensation
- Over voltage protection & Hiccup
- Over temperature protection
- Available in a 6-Pin SOT23-6 Package

2 APPLICATIONS

- Battery-Powered Equipment
- Set-Top Boxed
- White LED Driver
- Power Bank
- DSL and Cable Modems and Routers

3 DESCRIPTION

The HM6133 is a constant frequency current mode step-up converter intended for small, low power applications. The HM6133 switches at 1.2MHz and allows the use of tiny, low cost capacitors and inductors 2mm or less in height. Internal soft start results in small inrush current and extends battery life.

The HM6133 features automatic shifting to pulse frequency modulation mode at light loads. The HM6133 includes under-voltage lockout, current limiting, and thermal overload protection to prevent damage in the event of an output overload. The HM6133 is available in a small SOT23-6 package.

TYPICAL APPLICATION

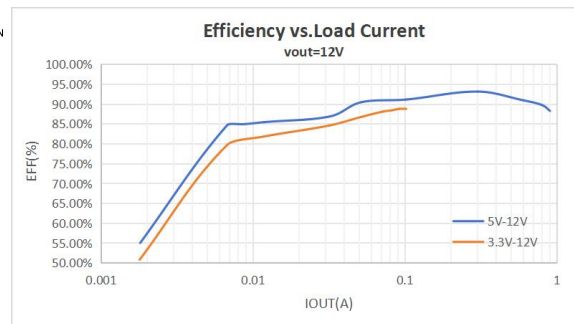
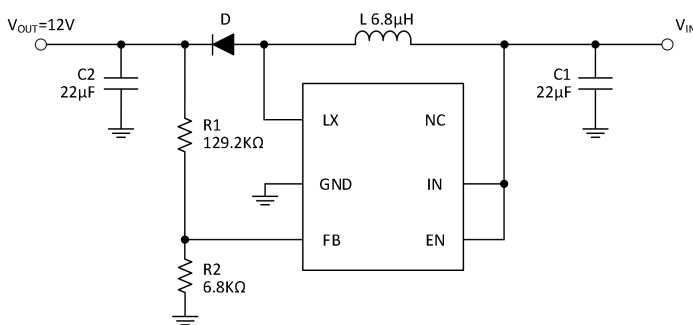

EFFICIENCY

4 PIN CONFIGURATION AND FUNCTIONS

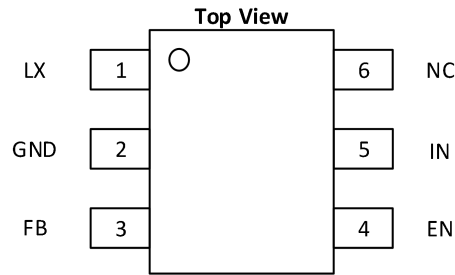

Pin	Symbol	Description
1	LX	Power Switch Output. LX is the drain of the internal MOSFET switch. Connect the power inductor and output rectifier to LX.
2	GND	Ground.
3	FB	Feedback Input. The FB voltage is 0.6V. Connect a resistor divider to FB.
4	EN	Regulator On/Off Control Input. A high input at EN turns on the converter, and a low input turns it off. When not used, connect EN to the input supply for automatic startup.
5	IN	Input Supply Pin. Must be locally bypassed.
6	NC	No Connection

5 ABSOLUTE MAXIMUM RATINGS⁽¹⁾

Parameter	Parameter	MIN	MAX	UNIT
V_{IN}	Input Supply Voltage	-0.3	6	V
V_{LX}	LX Voltages	-0.3	30	V
V_{EN}	EN Voltage	-0.3	6	V
V_{FB}	FB Voltage	-0.3	6	V
T_J	Junction Temperature ⁽²⁾	-40	155	°C
P	Power Dissipation		500	mW
T_L	Lead Temperature(Soldering, 10s)		260	°C

Stresses above those listed in “Absolute Maximum Ratings” may cause permanent damage to the device. This is a stress only rating and operation of the device at these or any other conditions above those indicated in the operational sections of this specification is not implied.

6 RECOMMENDED OPERATING CONDITIONS

Parameter	Parameter	MIN	MAX	UNIT
V_{IN}	Input Supply Voltage	2.5	5.5	V
T_J	Operating Junction Temperature Range	-40	85	°C

7 PACKAGE THERMAL CHARACTERISTICS

Parameter	Parameter	VALUE	UNIT
θ_{JA}	Junction to ambient Thermal Resistance	150	°C/W
θ_{JC}	Junction to case(top) Thermal Resistance	68.5	°C/W
ψ_{JB}	Junction to board characterization parameter	36.3	°C/W

8 ESD RATING

Parameter	Parameter	VALUE	UNIT
V_{ESD}	Human Body Model for all pins	±2000	V

9 BLOCK DIAGRAM

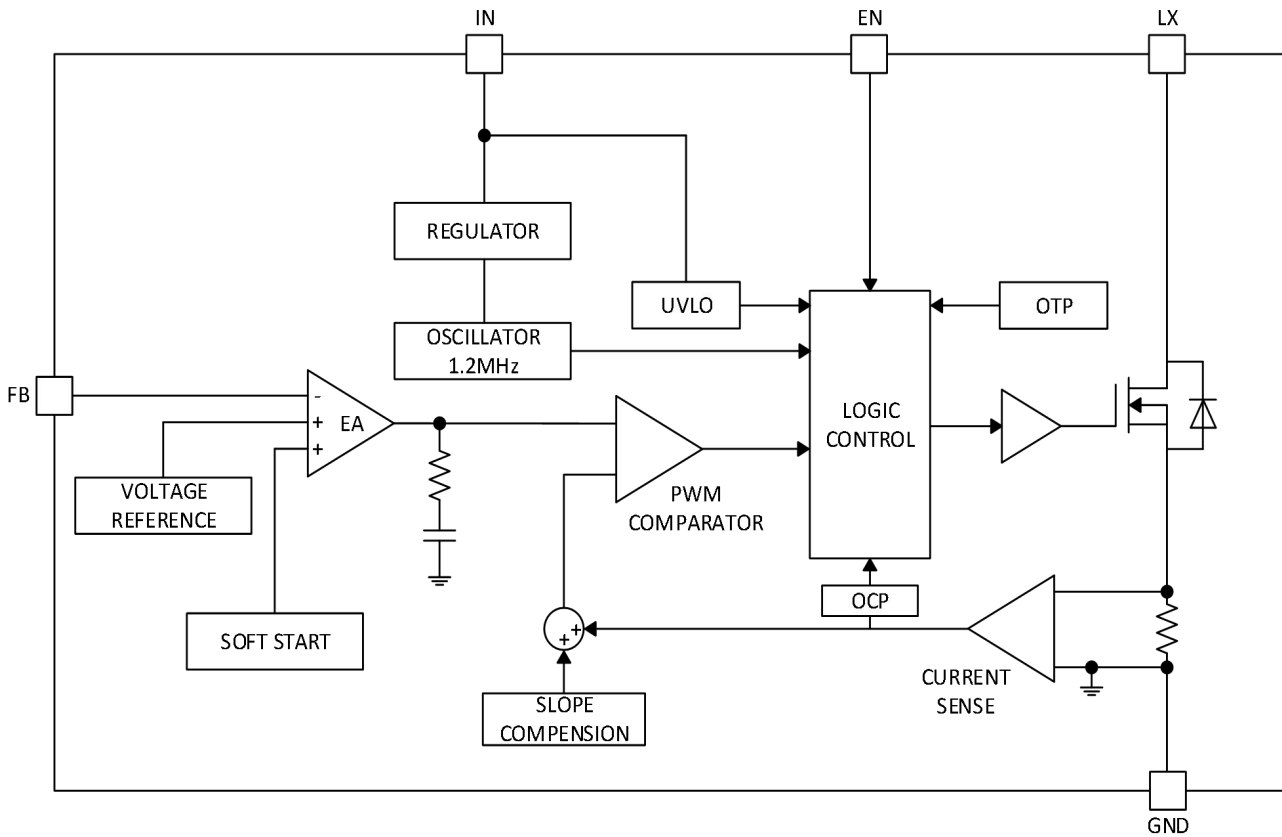

Functional Block Diagram

10 ELECTRICAL CHARACTERISTICS
 $V_{IN}=12V, V_{OUT}=5V, R_1=130K, R_2=6.8K, C_{IN}=C_{OUT}=22\mu F, L=6.8\mu H, T_A=25^\circ C.$

PARAMETER	Symbol	TEST CONDITIONS	MIN	TYP	MAX	UNIT
Operating Input Voltage	V_{IN}		2.5		5.5	V
Under Voltage Lockout		V_{IN} rising		2.3		V
Under Voltage Lockout Hysteresis				200		mV
Shutdown Current		$V_{EN} = 0V$		0.1	1	μA
Quiescent Current		$V_{FB} = 1.2V$, No switch		45		μA
Switching Frequency	f_{SW}			1.2		MHz
Maximum Duty Cycle		$V_{FB} = 0V$		90		%
EN Input High Voltage		V_{EN} Rising	1.3			V
EN Input Low Voltage		V_{EN} Rising, $V_{IN} = 2.5V$			1.1	V
FB Voltage	V_{FB}		0.588	0.6	0.612	V
LX On Resistance				80		m Ω
LX Current Limit		$V_{IN} = 5V$, Duty cycle = 50%		3		A
LX Leakage		$V_{LX} = 12V$			1	μA
Thermal Shutdown Threshold ⁽³⁾				155		$^\circ C$
Thermal Shutdown Hysteresis ⁽³⁾				20		$^\circ C$

1: Absolute Maximum Ratings are those values beyond which the life of a device may be impaired.

2: T_J is calculated from the ambient temperature T_A and power dissipation P_D according to the following formula: $T_J = T_A + P_D \times \theta_{JA}$.

3: Thermal shutdown threshold and hysteresis are guaranteed by design.

11 TYPICAL CHARACTERISTICS

$V_{IN} = 5V, V_O = 12V, L1 = 6.8\mu H, C_{OUT} = 22\mu F, C_{IN} = 22\mu F, T_A = +25^\circ C$, unless otherwise noted.

Startup through Enable

$V_{IN} = 12V, V_{out} = 5V, I_{out} = 0.5A$

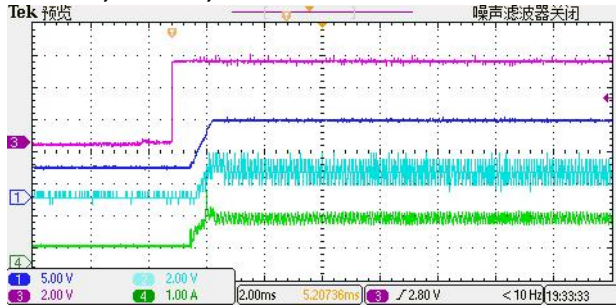

Shutdown through Enable

$V_{IN} = 12V, V_{out} = 5V, I_{out} = 0.5A$

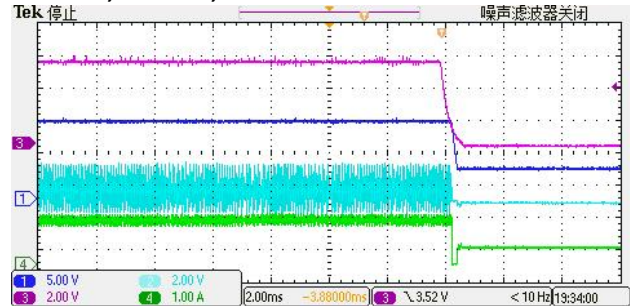

Startup through VIN

$V_{IN} = 12V, V_{out} = 5V, I_{out} = 0A$

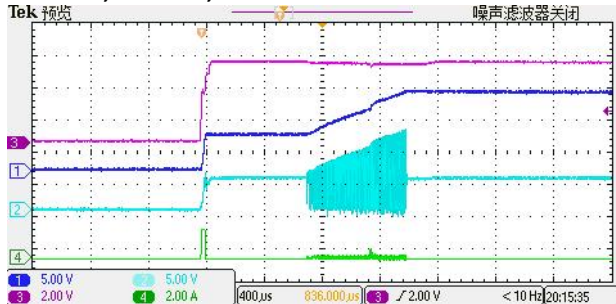

Shutdown through VIN

$V_{IN} = 12V, V_{out} = 5V, I_{out} = 0A$

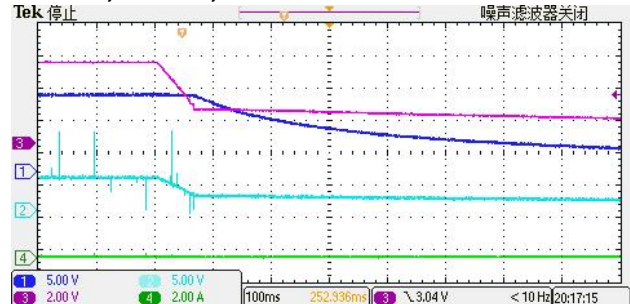

Output Ripple(12V=>5V,Load=0A)

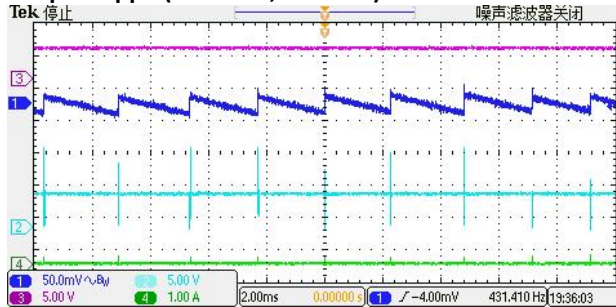

Heavy Load Operation(0.3A LOAD)

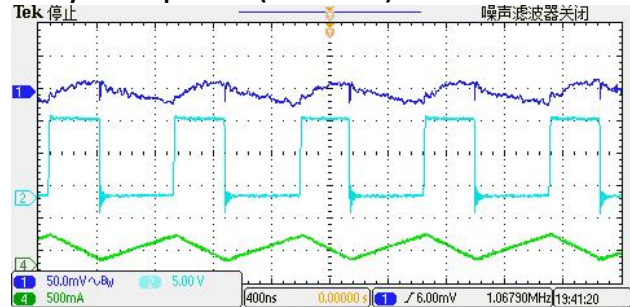

Output Ripple(12V=>5V,Load=0.8A)

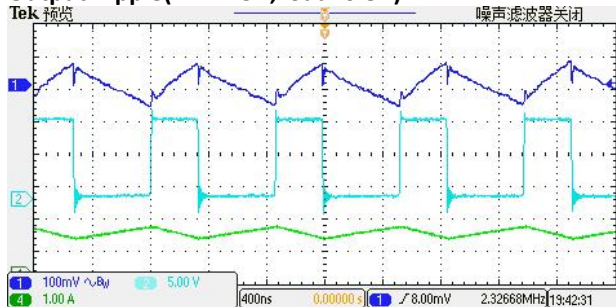

Short&Hiccup Protection

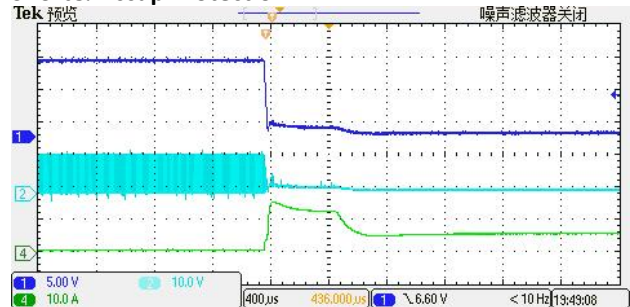

Load Transient(0.1A--0.3A Load)

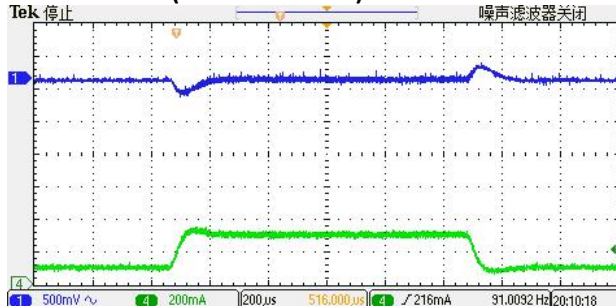

Load Transient(0.1A--0.5A Load)

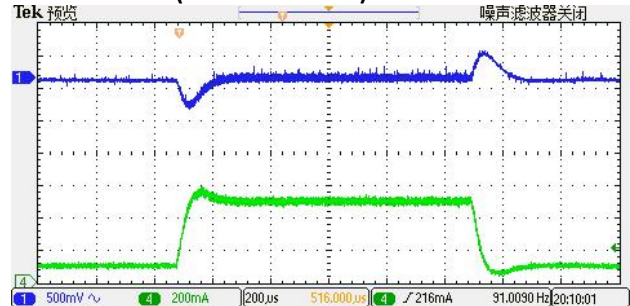

12 OPERATION

The HM6133 uses a fixed frequency, peak current mode boost regulator architecture to regulate voltage at the feedback pin. The operation of the HM6133 can be understood by referring to the block diagram. At the start of each oscillator cycle the MOSFET is turned on through the control circuitry. To prevent sub-harmonic oscillations at duty cycles greater than 50 percent, a stabilizing ramp is added to the output of the current sense amplifier and the result is fed into the negative input of the PWM comparator.

When this voltage equals the output voltage of the error amplifier the power MOSFET is turned off. The voltage at the output of the error amplifier is an amplified version of the difference between the band gap reference voltage and the feedback voltage. In this way the peak current level keeps the output in regulation. If the feedback voltage starts to drop, the output of the error amplifier increases. These results in more current to flow through the power MOSFET, thus increasing the power delivered to the output. The HM6133 has internal soft start to limit the amount of input current at startup and to also limit the amount of overshoot on the output.

13 APPLICATION INFORMATION

SETTING THE OUTPUT VOLTAGE

The external resistor divider sets the output voltage. The feedback resistor R1 also sets the feedback-loop bandwidth through the internal compensation capacitor (see the Typical Application circuit). Choose R1 around 10kΩ, and R2 by:

$$R2 = R1 / (V_{OUT}/0.6V - 1)$$

INDUCTOR SELECTION

The recommended values of inductor are 4.7μH to 22μH. Small size and better efficiency are the major concerns for portable device, such as HM6133 used for mobile phone. The inductor should have low core loss at 1.2MHz and low DCR for better efficiency. To avoid inductor saturation current rating should be considered.

CAPACITOR SELECTION

Input and output ceramic capacitors of 22μF are recommended for HM6133 applications. For better voltage filtering, ceramic capacitors with low ESR are recommended. X5R and X7R types are suitable because of their wider voltage and temperature ranges.

DIODE SELECTION

Schottky diode is a good choice for HM6133 because of its low forward voltage drop and fast reverses recovery. Using Schottky diode can get better efficiency. The high-speed rectification is also a good characteristic of Schottky diode for high switching frequency. Current rating of the diode must meet the root mean square of the peak current and output average current multiplication as following:

$$I_D(RMS) \approx \sqrt{I_{OUT}} \times \sqrt{I_{PEAK}}$$

The diode's reverse breakdown voltage should be larger than the output voltage.

14 LAYOUT

PCB layout is very important to achieve stable operation. Please follow the guidelines below.

1. Input and Output capacitors should be placed close to the IC and connected to ground plane to reduce noise coupling.
2. The GND should be connected to a strong ground plane for heat sinking and noise protection.
3. Keep the main current traces as possible as short and wide.
4. LX node of DC-DC converter is with high frequency voltage swing. It should be kept at a small area.
5. Place the feedback components as close as possible to the IC and keep away from the noisy devices.

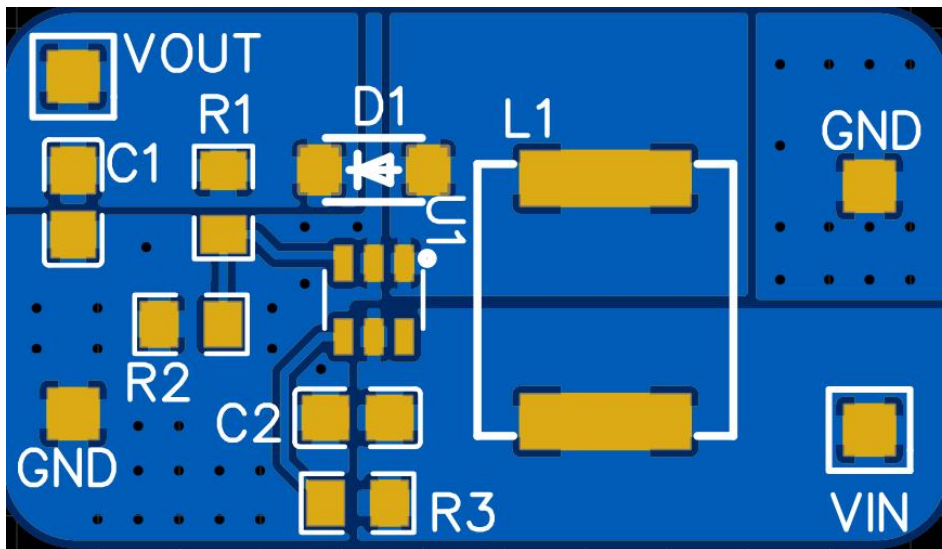

PACKAGE DIMENSIONS

SOT23-6

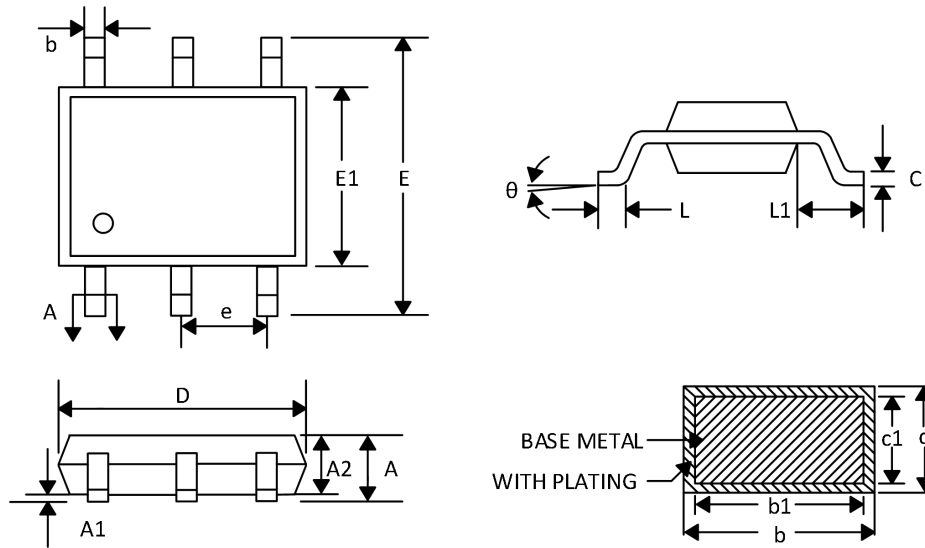

Symbol	MIN	NOM	MAX
A	-	-	1.25
A1	0.03	0.08	0.15
A2	1.05	1.10	1.15
b	0.27	-	0.35
b1	0.26	0.285	0.31
c	0.135	-	0.23
c1	0.127	0.152	0.178
D	2.82	2.92	3.02
E	2.60		3.00
E1	1.50	2.90	1.70
e	0.95BSC		
L	0.35	0.45	0.55
L1	0.49	0.64	0.79
θ	0°	-	8°

Order Information

Order number	Package	Marking information	Operation Temperature Range	MSL Grade	Ship, Quantity	Green
HM6133	SOT23-6	HM6133	-40 to 85°C	3	T&R,3000	Rohs