



## **E07-400M10S**

**CC1101 410-450MHz 10dBm SPI Wireless Module**

## Contents

Disclaimer .....	3
1. Overview .....	4
1.1 Brief Introduction .....	4
1.2 Features .....	4
1.3 Application .....	4
2. Specification and parameter .....	5
2.1 Limit parameter .....	5
2.2 Operating parameter .....	5
3. Size and pin definition .....	6
4. Basic operation .....	7
4.1 Hardware design .....	7
4.2 Programming .....	8
5. Basic application .....	8
6. FAQ .....	8
6.1 Communication range is too short .....	8
6.2 Module is easy to damage .....	9
6.3 BER(Bit Error Rate) is high .....	9
7. Production guidance .....	9
8. E07 series .....	9
9. Antenna guide .....	10
9.1 Antenna recommendation .....	10
Revision history .....	10
About us .....	11

## **Disclaimer**

The information in this document, including the URL address for reference, is subject to change without notice. The document is provided "as is" without any guarantee responsibility, including any guarantee for marketability, suitability for a specific purpose, or non-infringement, and any guarantee for any proposal, specification or sample mentioned elsewhere. This document does not bear any responsibility, including the responsibility for infringement of any patent rights caused by the use of the information in this document. This document does not grant any license for the use of intellectual property rights in estoppel or other ways, whether express or implied.

The test data obtained in the article are all obtained by the Ebyte laboratory, and the actual results may vary slightly.

We hereby declared that all brand names, trademarks and registered trademarks mentioned in this document are the property of their respective owners.

The final interpretation right belongs to Chengdu Ebyte Electronic Technology Co., Ltd.

Notice :

Due to product version upgrades or other reasons, the contents of this manual may be changed. Ebyte Electronic Technology Co., Ltd. reserves the right to modify the contents of this manual without any hint or notice. This manual is only used as a guide. Chengdu Ebyte Electronic Technology Co., Ltd. makes every effort to provide accurate information in this manual. However, we do not guarantee that the contents of the manual are completely free of errors. All statements, information and suggestions in this manual do not constitute any express or implied guarantee.

# 1 OVERVIEW

## 1.1 Brief Introduction

E07-400M10S is an independently developed 410-450MHz SMD wireless module based on the CC1101 chip produced by Texas Instruments (TI), using industrial-grade high-precision 26MHz crystal oscillator.

Due to the adoption of the already mature CC1101 chip as the core of the module, its stability has won unanimous praise from users, and there is no need to worry about compatibility. This module is mainly aimed at smart home, industry, scientific research and medical, and short-distance wireless communication equipment. It can provide extensive hardware support for data packet processing, data buffering, burst transmission, received signal strength indicator (RSSI), clear channel assessment (CCA), link quality indicator, and wireless wake-up (WOR).

Since the module is a pure RF transceiver module, you need to use the MCU driver or a dedicated SPI debugging tool.

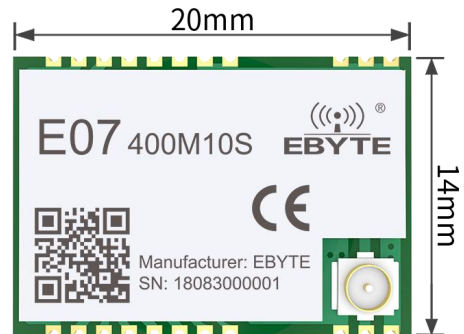

## 1.2 Features

- The measured communication distance can reach 1500m;
- Maximum transmission power of 10mW, software multi-level adjustable;
- Support the license-free ISM 433MHz band;
- Support air data rate of 0.6k~500kbps;
- Support multiple modulation modes (OOK、ASK、GFSK、2-FSK、4-FSK and MSK)
- Independent 64-byte RX FIFO and TX FIFO;
- Support 2.5~3.6V power supply, power supply over 3.3 V can guarantee the best performance;
- Industrial grade standard design, support -40 ~ 85 °C for working over a long time;
- IPEX interface, which can be easily connected to external antenna;
- Support RSSI (received signal strength indicator) and LQI (link quality indicator)
- It is connected to the MCU through a 4-wire SPI interface and provides 2 general-purpose digital output pins with programmable functions.

## 1.3 Application

- Smart home and industrial sensors, etc.;
- Wireless alarm security system;
- Home security alarm and remote keyless entry;
- Wireless industrial-grade remote control;

- Health care products;
- Advanced Meter Reading Architecture(AMI);
- Automotive industry applications.

## 2 Specification and Parameter

### 2.1 Limit Parameter

Main parameter	Performance		Remark
	Min	Max	
Power supply (V)	0	3.6	Voltage over 3.6V will cause permanent damage to module
Blocking power (dBm)	-	10	Chances of burn is slim when modules are used in short distance
Operating temperature (°C)	-40	+85	Industrial grade

### 2.2 Operating Parameter

Main parameter		Performance			Remark
		Min	Typical	Max	
Operating voltage (V)		2.5	3.3	3.6	3.3 V ensures output power
Communication level (V)		-	3.3	-	For 5V TTL, it may be at risk of burning down
Operating temperature (°C)		-40	-	+85	Industrial grade
Operating frequency (MHz)		410	433	450	Support ISM band
Power Consumption	TX current (mA)	-	35	-	Instant power consumption
	RX current (mA)	-	18	-	-
	Sleep current (μA)	-	0.6	-	Shut down by software
Max TX power (dBm)		9.5	10	11	-
Receiving sensitivity (dBm)		-107	-108	-109	Air data rate is 1.2kbps
Air data rate (bps)		0.6k	-	500k	Controlled via user's programming

Main parameter	Description	Remark
Reference distance	1.5km	Test condition: clear and open area, antenna gain: 5dBi, antenna height: 2.5m, air data rate: 1.2kbps
FIFO	64Byte	Maximum length of a single transmission
Crystal Oscillator	26MHz	10ppm
Modulation	GFSK(recommended)	Support OOK、ASK、GFSK、2-FSK、4-FSK and MSK

Package	SMD	-
Interface method	1.27mm	Half hole
Communication Interface	SPI	0~10Mbps
Size	14*20mm	-
Antenna	IPEX/STAMP	50 ohm impedance
Net Weight	1.2g	-

### 3 Size and Pin definition

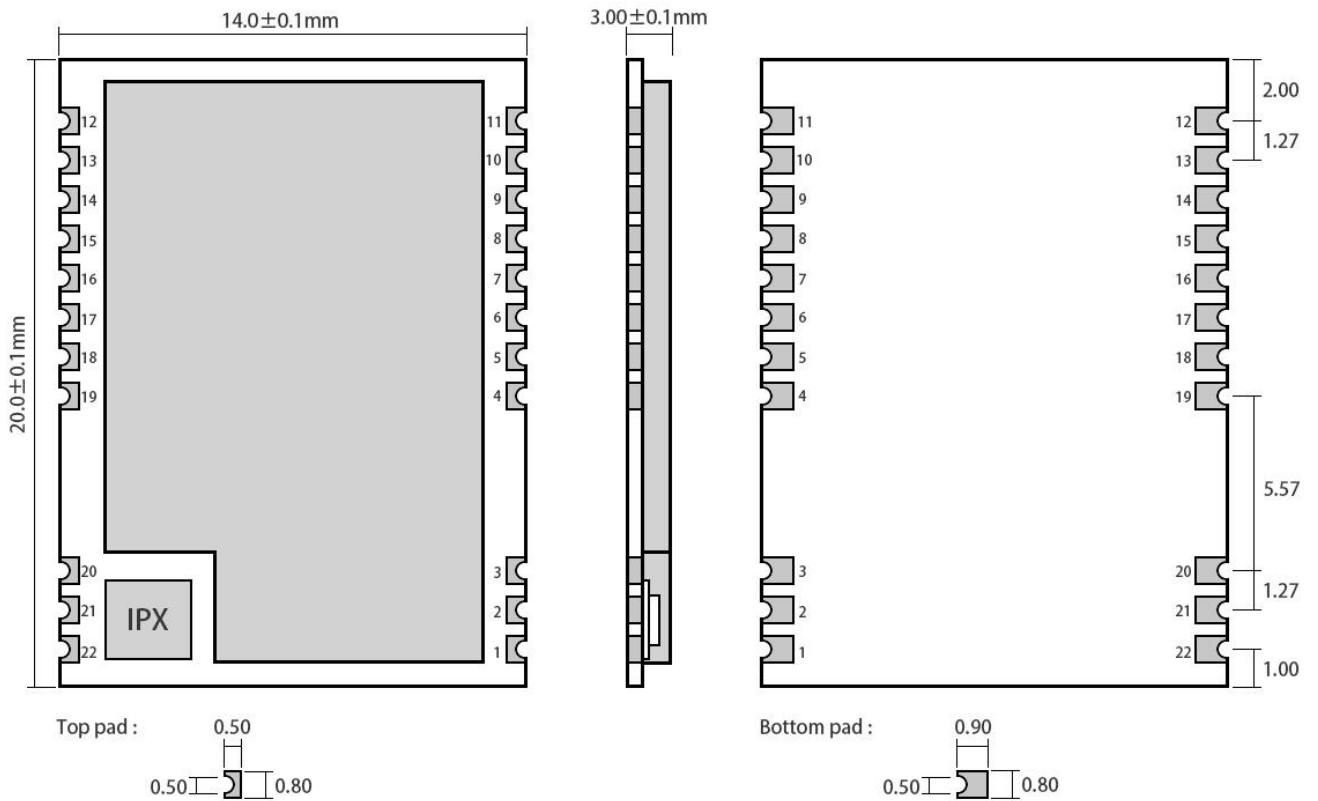

Pad quantity : 22  
Unit: mm

Pin No.	Item	Direction	Description
1	GND		Ground wire, connected to the power reference ground
2	GND		Ground wire, connected to the power reference ground
3	GND		Ground wire, connected to the power reference ground
4	GND		Ground wire, connected to the power reference ground
5	GND		Ground wire, connected to the power reference ground
6	NC		No need to connect
7	NC		No need to connect
8	NC		No need to connect
9	VCC		Power supply, 2.5~3.6V (It is also recommended to add external ceramic filter capacitor)

10	NC		No need to connect
11	GND		Ground wire, connected to the power reference ground
12	GND		Ground wire, connected to the power reference ground
13	NC		No need to connect
14	GD02		CC1101 chip pins (see CC1101 official user manual for details)
15	GD00		CC1101 chip pins (see CC1101 official user manual for details)
16	MISO/GD01	Output	SPI master output slave input
17	MOSI	Input	SPI master input slave output
18	SCK	Input	Serial Clock Input
19	CSN	Input	SPI Chip select for starting SPI communication
20	GND		Ground wire, connected to the power reference ground
21	ANT	Input/Output	Antenna, stamp hole (50 ohm impedance)
22	GND		Ground wire, connected to the power reference ground

## 4 Basic operation

### 4.1 Hardware design

- It is recommended to use a DC stabilized power supply. The power supply ripple factor is as small as possible and the module needs to be reliably grounded;
- Please pay attention to the correct connection of the positive and negative poles of the power supply, reverse connection may cause permanent damage to the module;
- Please check the power supply to ensure that between the recommended supply voltage, if exceeding the maximum, the module will be permanently damaged;
- Please check the stability of the power supply. Voltage can not fluctuate greatly and frequently;
- When designing the power supply circuit for the module, it is often recommended to reserve more than 30% of the margin, so the whole machine is beneficial for long-term stable operation;
- The module should be as far away as possible from the power supply, transformers, high-frequency wiring and other parts with large electromagnetic interference;
- Bottom Layer High-frequency digital routing, high-frequency analog routing, and power routing must be avoided under the module. If it is necessary to pass through the module, assume that the module is soldered to the Top Layer, and the copper is spread on the Top Layer of the module contact part(well grounded), it must be close to the digital part of the module and routed in the Bottom Layer;
- Assuming the module is soldered or placed over the Top Layer, it is wrong to randomly route over the Bottom Layer or other layers, which will affect the module's spurs and receiving sensitivity to varying degrees;
- It is assumed that there are devices with large electromagnetic interference around the module that will greatly affect the performance. It is recommended to keep them away from the module according to the strength of the interference. If necessary, appropriate isolation and shielding can be done;
- Assume that there are traces with large electromagnetic interference (high-frequency digital, high-frequency analog, power traces) around the module that will greatly affect the performance of the module. It is recommended to stay away from the module according to the strength of the interference. If necessary, appropriate isolation and shielding

can be done;

- If the communication line uses a 5V level, a 1k-5.1k resistor must be connected in series (not recommended, there is still a risk of damage);
- The mounting structure of antenna has a great influence on the performance of the module. It is necessary to ensure that the antenna is exposed, preferably vertically upward. When the module is mounted inside the case, use a good antenna extension cable to extend the antenna to the outside;
- The antenna must not be installed inside the metal case, which will cause the transmission distance to be greatly weakened.

## 4.2 Programming

- It can complete the wireless data transceiving by operating its control register and transceiving buffer. Please refer to the latest CC1101 data sheet for the timing operation of module register.
- GDO0 is a general purpose I/O port, see CC1101 user manual;
- GDO2 is generally configured as an IRQ-like function, or not connected. SPI query mode can be used to obtain the interrupt status, but it is still recommended to use external interrupt by connecting to a MCU;
- After CC1101 restores IDLE mode or configured as sleep mode, it is recommended to reinitialize the power configuration table.

## 5 Recommended circuit diagram

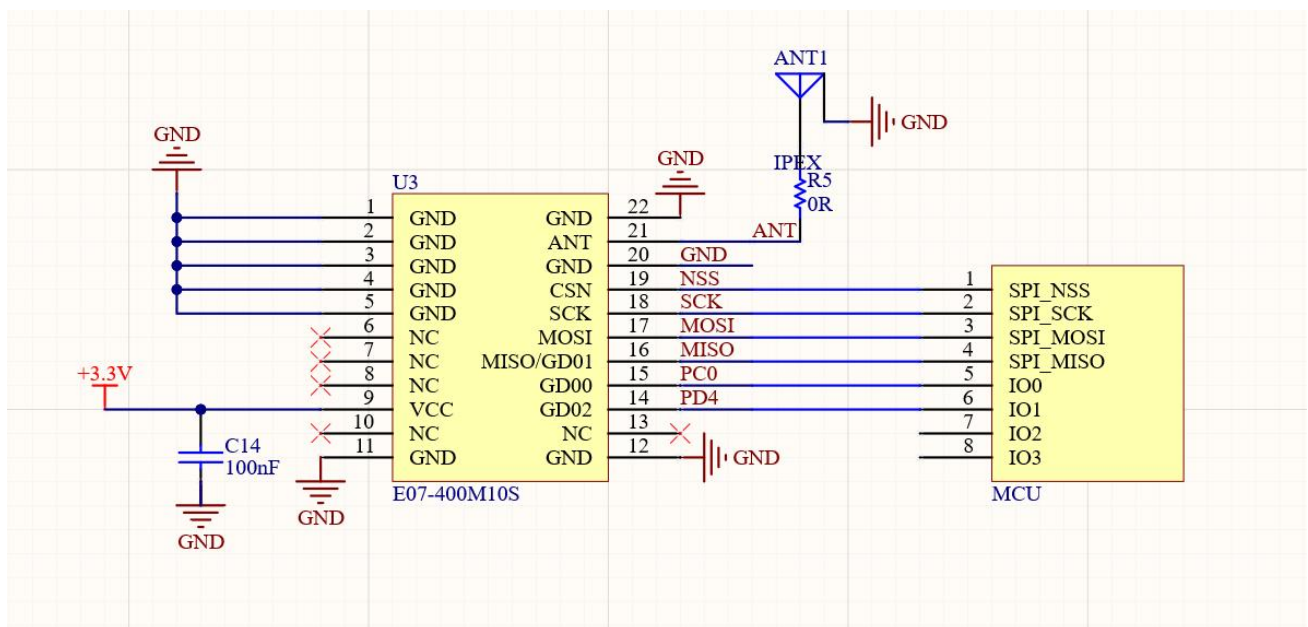

## 6 FAQ

### 6.1 Communication range is too short

- The communication distance will be affected when obstacle exists;
- Data lose rate will be affected by temperature, humidity and co-channel interference;
- The ground will absorb and reflect wireless radio wave, so the performance will be poor when testing near ground;
- Sea water has great ability in absorbing wireless radio wave, so performance will be poor when testing near the sea;
- The signal will be seriously affected when the antenna is near metal object or put in a metal case;
- Power register was set incorrectly or air data rate is set as too high (the higher the air data rate, the shorter the distance);
- The power supply low voltage under room temperature is lower than our recommendation, the lower the voltage, the lower the transmitting power;
- Due to antenna quality or poor matching between antenna and module.

### 6.2 Module is easy to damage

- Please check the power supply source, ensure it is 1.8V~3.6V, voltage higher than 3.6V will damage the module;
- Please check the stability of power source, the voltage cannot fluctuate too much;
- Please make sure anti-static operation when installing and using, high frequency devices have electrostatic susceptibility;
- Please ensure the humidity is within limited range, some parts are sensitive to humidity;
- Please avoid using modules under too high or too low temperature.

### 6.3 BER(Bit Error Rate) is high

- There are co-channel signal interference nearby, please be away from interference sources or modify frequency and channel to avoid interference;
- The clock waveform on SPI is not standard, check whether there is interference on the SPI line, and the SPI bus line should not be too long;
- Poor power supply may cause messy code. Make sure that the power supply is reliable;
- The extension line and feeder quality are poor or too long, so the bit error rate is high.

## 7 Production guidance

This product is a SMD module. When soldering the module, the soldering personnel must work in accordance with the anti-static operation specification;

This product is an electrostatic sensitive product. If the module is not welded according to the specification, the module may be permanently damaged.

## 8 E07 series

Model No.	IC	Frequency	Tx power	Distance	Package	Antenna
		Hz	dBm	m		
<a href="#">E07-400M10S</a>	CC1101	433M	10	1500	SMD	STAMP
<a href="#">E07-900M10S</a>	CC1101	868M/915M	10	1500	SMD	STAMP

All modules in E07 series can communicate with each other

## 9 Antenna Guide

### 9.1 Antenna recommendation

The antenna is an important role in the communication process. A good antenna can largely improve the communication system. Therefore, we recommend some antennas for wireless modules with excellent performance and reasonable price.

Model No.	Type	Frequency	Gain	Size	Feeder	Interface	Function featur
		Hz	dBi	mm	cm		
<a href="#">TX433-NP-4310</a>	Flexible antenna	433M	2.0	10x43	-	Welding	FPC soft antenna
<a href="#">TX433-JZ-5</a>	Rubber antenna	433M	2.0	30	-	SMA-J	Ultra-short and straight, omnidirectional antenna
<a href="#">TX433-JZG-6</a>	Rubber antenna	433M	2.5	50	-	SMA-J	Ultra-short and straight, omnidirectional antenna
<a href="#">TX433-JW-5</a>	Rubber antenna	433M	2.0	50	-	SMA-J	Fixed bending, omnidirectional antenna
<a href="#">TX433-JWG-7</a>	Rubber antenna	433M	2.5	110	-	SMA-J	Fixed bending, omnidirectional antenna
<a href="#">TX433-JK-11</a>	Rubber antenna	433M	2.5	110	-	SMA-J	Bendable rubber antenna, omnidirectional
<a href="#">TX433-JK-20</a>	Rubber antenna	433M	3.0	200	-	SMA-J	Bendable rubber antenna, omnidirectional
<a href="#">TX433-XPL-100</a>	Sucker antenna	433M	3.5	185	100	SMA-J	Small sucker antenna, cost-effective
<a href="#">TX433-XP-200</a>	Sucker antenna	433M	4.0	190	200	SMA-J	Small sucker antenna, low loss
<a href="#">TX433-XPB-300</a>	Sucker antenna	433M	6.0	965	300	SMA-J	Small sucker antenna, high gain

## Revision history

Version	Date	Description	Issued by
1.0	2021-06-18	Initial version	Linson
1.1	2022-5-11	Bug fixes	Yan
1.2	2022-10-27	Bug fixes	Yan

## About us



Sales hotline: 0086-4000-330-990

Tel: 0086-28-61399028

Technical support: [support@cdebyte.com](mailto:support@cdebyte.com)

Website: <https://www.cdebyte.com>

Address : Building B5, Mould Industrial Park, 199# Xi-Qu Ave, West High-tech Zone, Chengdu, 611731, Sichuan, China

