

标记 MARK	ECN编号/变更内容 ECN NO/DEFINITION	修改 REVISE	日期 DATE	核准 APPROVE

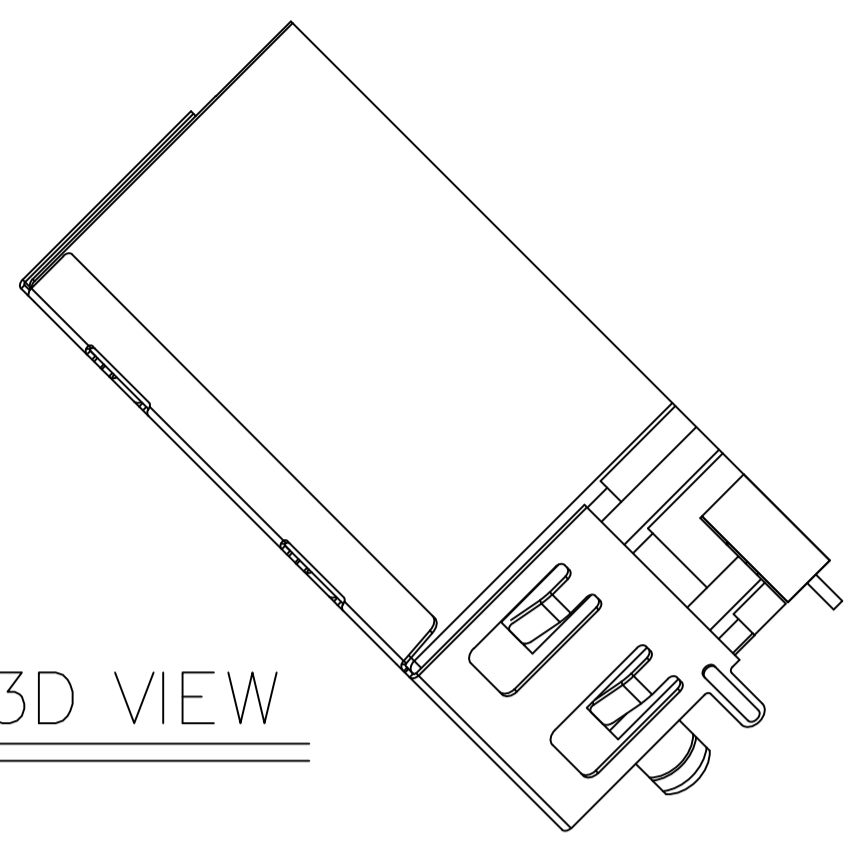
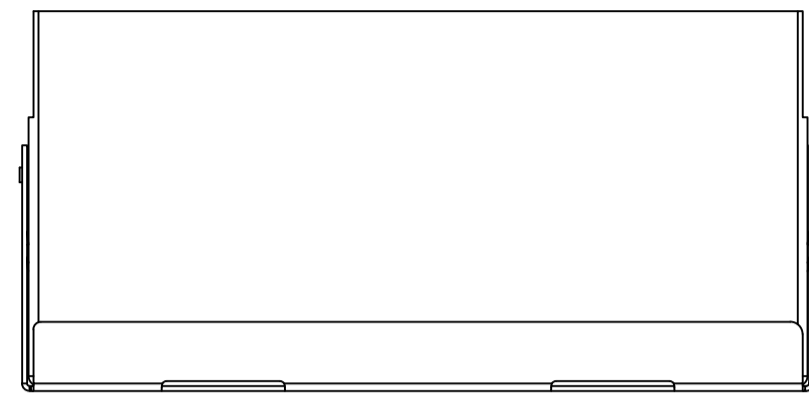

3D VIEW

NOTES:

- 1. MATERIAL:
 - 1.1.HOUSING:PBT ,COLOR IS BLCAK;
 - 1.2.CONTACT: PHOSPHOR BRONZE, $\phi 0.46 \pm 0.02\text{mm}$;
- 2. FINISH: PLATED GOLD OVER NI;
- 3. RECINNEBDED PCB THICKNESS: 1.60mm;
- 4. ELECTRICAL:
 - 4.1. VOLTAGE RATING: 125 VAC RMS;
 - 4.2. CURRENT RATING: 1.5 AMP;
 - 4.3. CONTACT RESISTANCE: 30MILLIOHMS MAX.;
 - 4.4. WITHSTAND VOLTAGE: 1000 VAC RMS 50(60)Hz,1MIN.;
 - 4.5. INSULATION RESISTANCE: 500MEGOHMS MIN @500V DC;
- 5. MECHANICAL:
 - 5.1. MATING/UNMATING FORCE: 30N MAX.;
 - 5.2. RETENTIION STRENGTH: 50N MIN.;
 - 5.3. OPERATING LIFE: 750 CYCLES MIN.;
- 6.SALT SPRAY TEST: 12H;
- 7. SOLDERABILITY: $245 \pm 5^\circ\text{C}, 5 \pm 0.5\text{S}$;
- 8. RESISTANCE TO SOLDER: $260 \pm 0.5^\circ\text{C}, 10 \pm 1\text{S}$;
- 9 ENVIRONMENTAL:
 - 9.1. STORAGE TEMPERATURE RANGE: $-40^\circ\text{C} \sim +85^\circ\text{C}$;
 - 9.2. OPERATION TEMPERATURE RANGE: $-25^\circ\text{C} \sim +70^\circ\text{C}$;

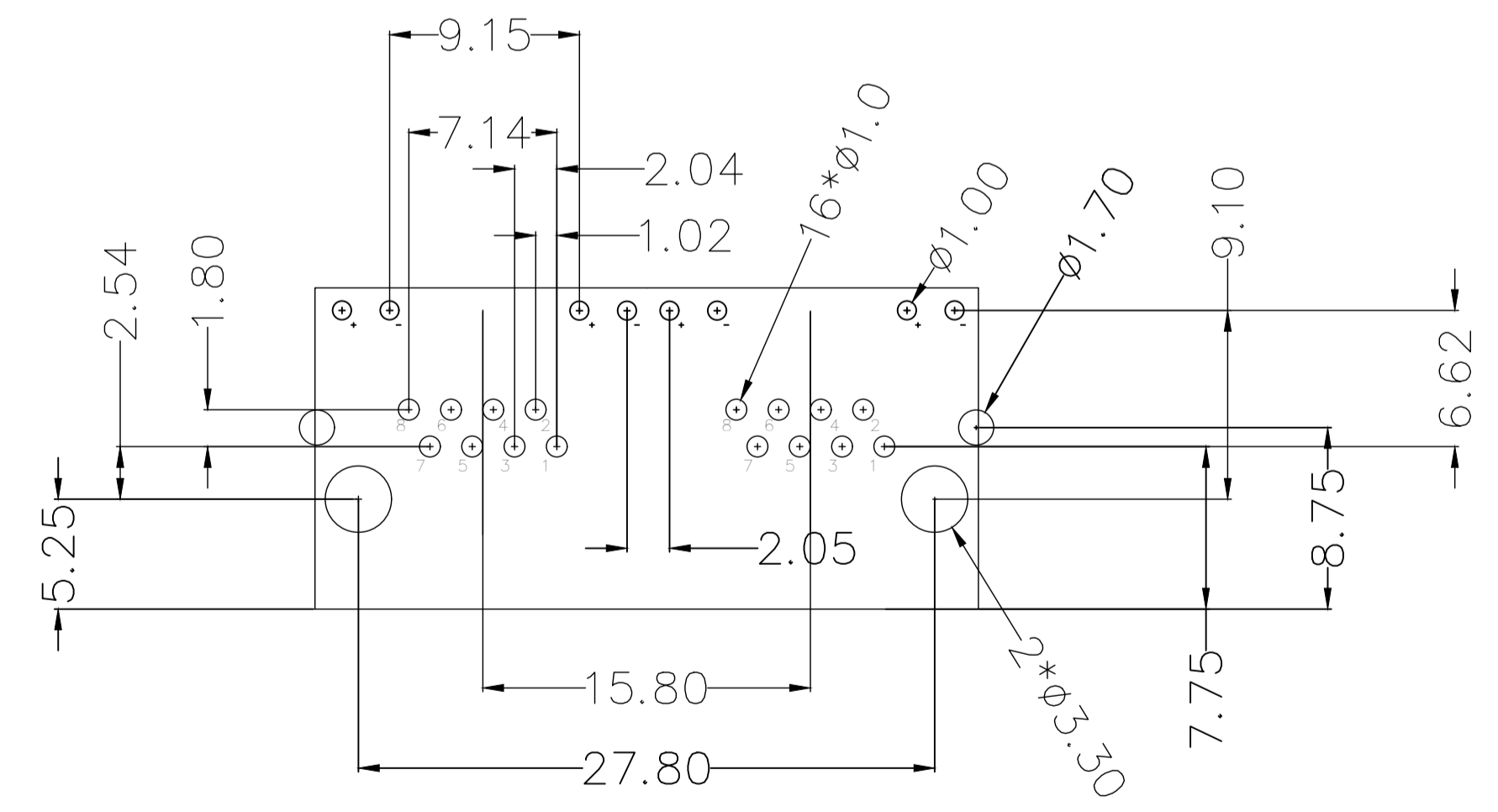
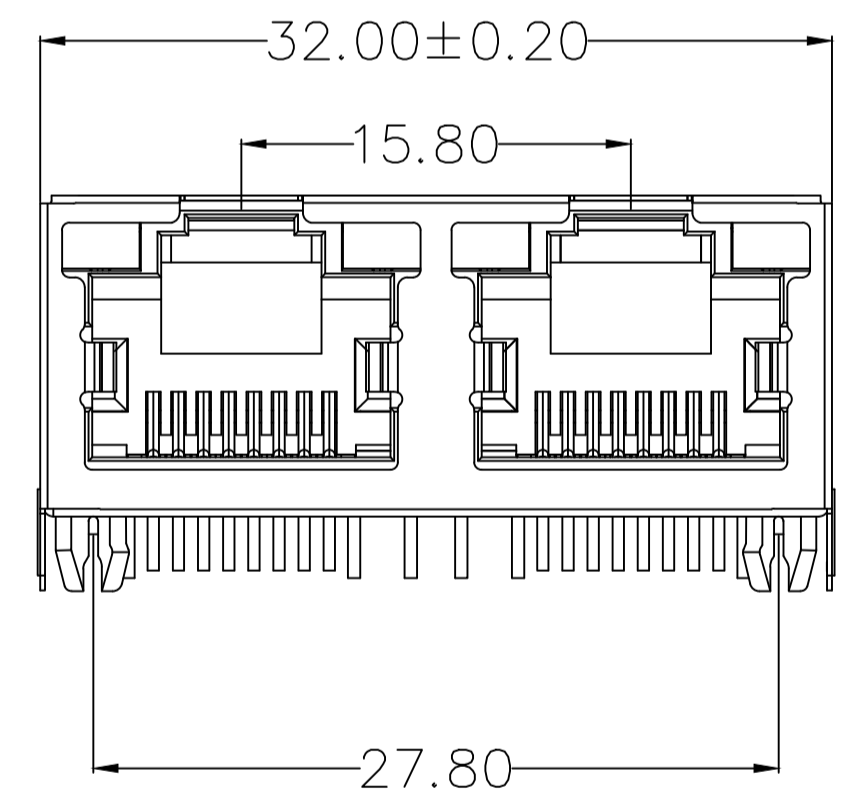
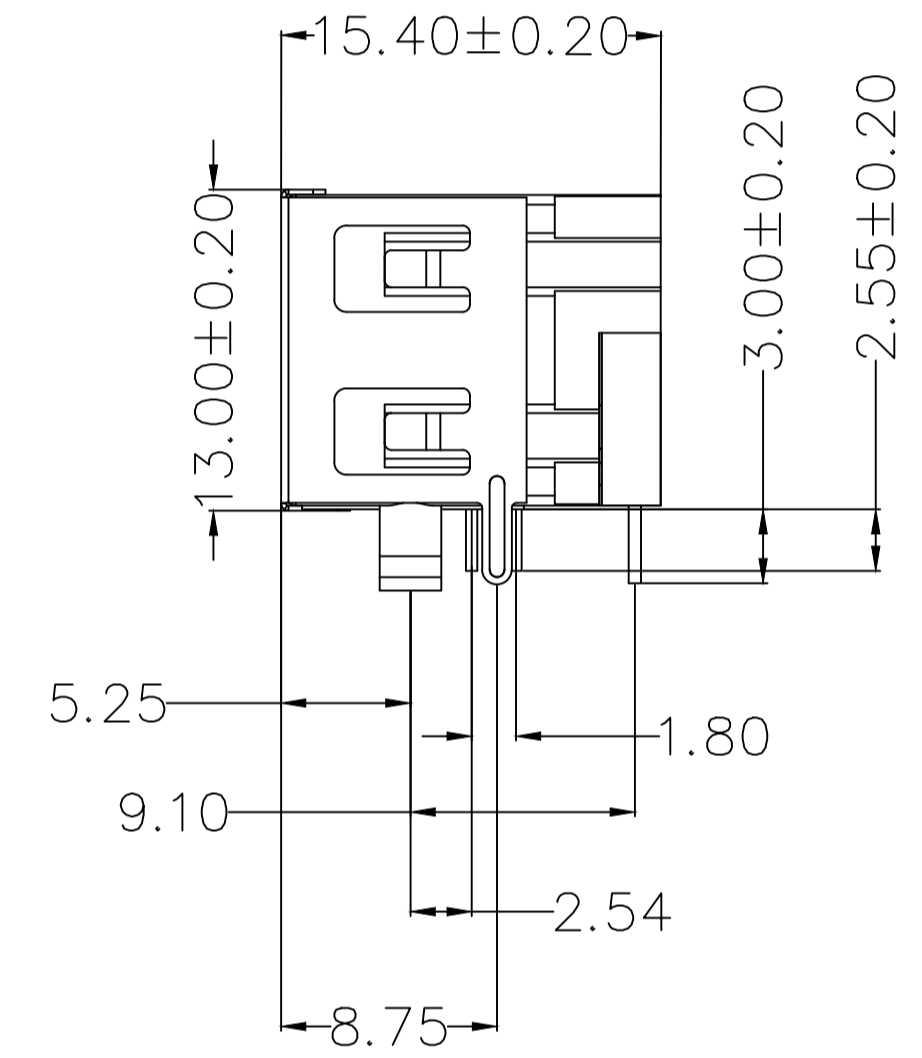
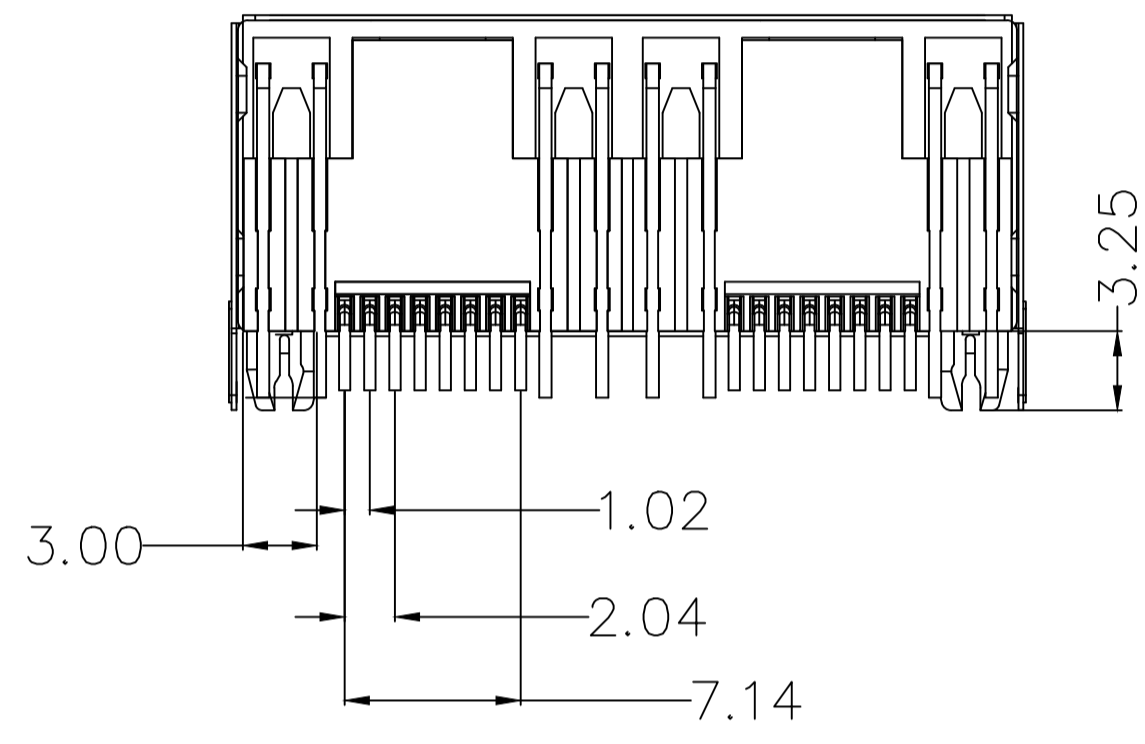

RECOMMENDED PCB LAYOUT
TOP VIEW(TOL: ±0.05)

3	外壳	不锈钢	镀镍	
2	接触	铜	镀金G/F	
1	基座	PBT	黑色	
序号	品名	材质	电镀/颜色	备注

	深圳市虹成电子有限公司		品名 TITLE	网口	
			料号 PART NO	HC-WK88-H16-1X2-DB	
UNLESS OTHERWISE, GENERAL TOLERANCE: X. xxx ±0.10 X. xx ±0.20 X. x ±0.30 ANGULAR: X. xx° ±1° X. x° ±3° X. ° ±5°		比列 SCALE	1:1		
		单位 UNIT	MM	制图 DRAW	AhYe
		张数 PART NO	1 OF 1	审核 CHECKED	夏操云
		版本 REV	A	批准 APPROVE	赵亮亮

