



Description

- Halogen Free
- 125°C maximum total temperature operation
- Magnetically shielded, low EMI
- High current carrying capacity, Low core losses
- Frequency range up to 5MHz
- RoHS compliant



Applications

- Voltage Regulator Module (VRM)
- Multi-phase regulators
- Point-of-load modules
- Smart phone POL modules
- SSD modules
- Notebook regulators
- Battery power systems
- Graphics cards
- Data networking and storage systems

Product Identification

GSM 0530 xxx M
① ② ③ ④

- ① Series name
- ② Dimensions
- ③ Inductance Value
- ④ Inductance Tolerance (M= $\pm 20\%$)

Dimensions-mm

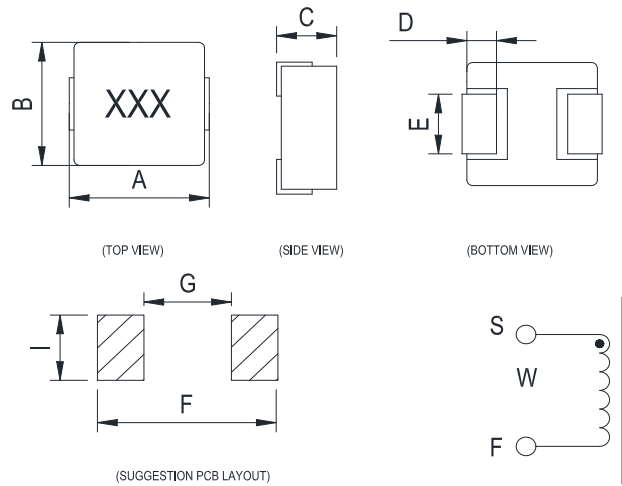

Series	A	B	C	D	E	F	G	I
GSM0530	5.7±0.3	5.2±0.3	3.0 Max	1.2±0.3	2.2±0.3	6.0 Typ	3.0 Typ	2.7 Typ

Electrical Characteristics

Part Number	Inductance	DC Resistance	Saturation Current	Heating Rating Current
	L (uH)	DCR(mΩ)	A	A
	±20 %-1MHz,1V	Max	Typ	Typ
GSM0530-1R0-M	1	12.5	9.5	9.0
GSM0530-2R2-M	2.2	22	7.0	6.5
GSM0530-3R3-M	3.3	33.5	6.0	5.5
GSM0530-4R7-M	4.7	54	5.0	4.5
GSM0530-6R8-M	6.8	86	4.0	3.5
GSM0530-100-M	10	104	3.5	3.0
GSM0530-150-M	15	218	3.0	2.5

Notes:

1. All test data is referenced to 25 °C ambient
2. Operating temperature range - 55 °C to + 125 °C
3. I_{dc}(A):DC current (A) that will cause an approximate ΔT of 40 °C
4. I_{sat}(A):DC current (A) that will cause L₀ to drop approximately 30 %
5. The part temperature (ambient + temp rise) should not exceed 125 °C under worst case operating conditions. Circuit design, component placement, PWB trace size and thickness, airflow and other cooling provisions all affect the part temperature. Part temperature should be verified in the end application.
6. Absolute maximum voltage 30VDC

Temperature rise curve graph

GSM0530-1R0-M

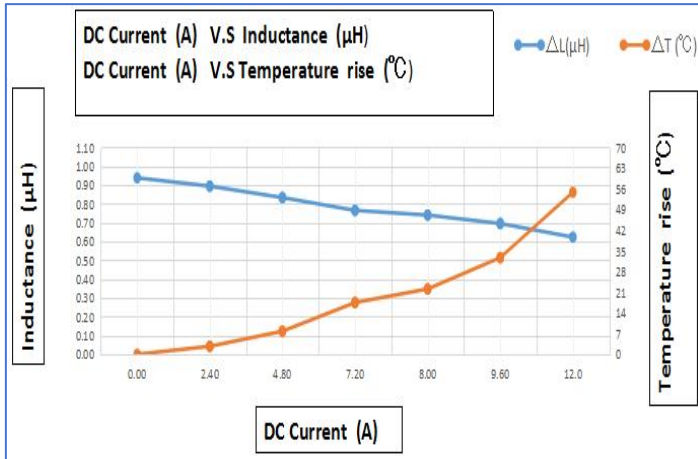

GSM0530-2R2-M

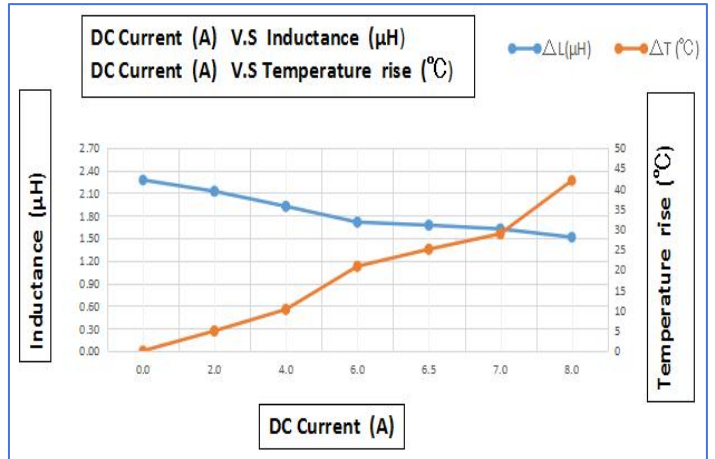

GSM0530-3R3-M

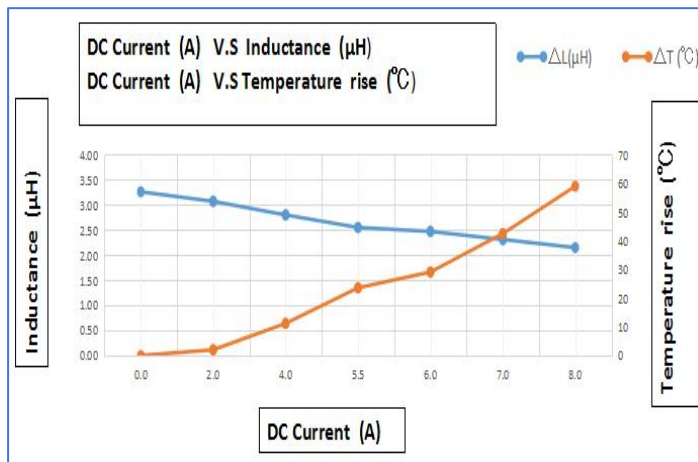

GSM0530-4R7-M

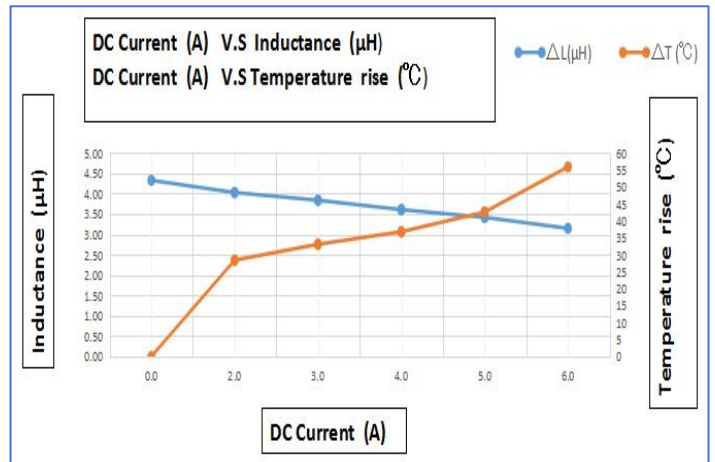

GSM0530-6R8-M

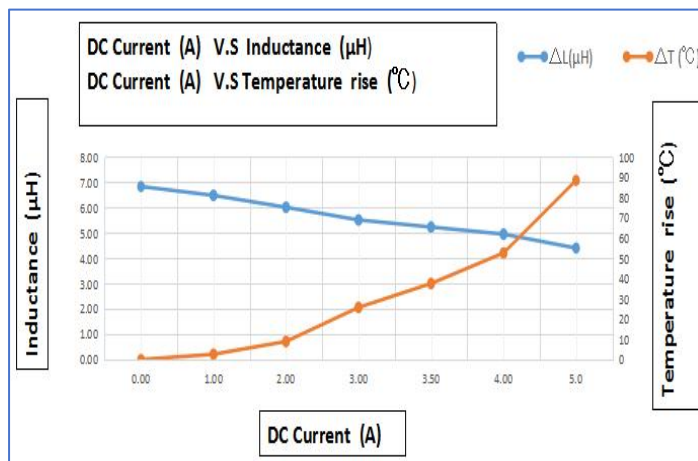

GSM0530-100-M

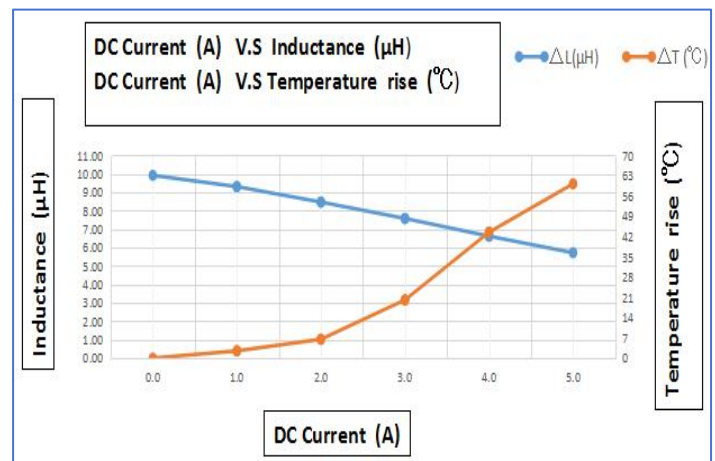

Temperature rise curve graph

